

# 185HE IS

## Greensand Filter

Owners Manual



Proud member of Canadian Institute of Plumbing & Heating.



Proud member of Canadian Water Quality Association.

1. Read all instructions carefully before operation.
2. Avoid pinched o-rings during installation by applying (provided with install kit) NSF certified lubricant to all seals.
3. This system is not intended for treating water that is microbiologically unsafe or of unknown quality without adequate disinfection before or after the system.

## Table of Contents

	PAGE
Unpacking / Inspection	2
Safety Guide	2
Proper Installation	3
Specification	4
Before Starting Installation	5
Sizing Requirements	7
Installation Instructions	8
System Start Up	9
Plumbing Clean Up	11
Programming	12
About The System	13
Maintenance	15
Sanitizing Procedure	15
Main Repair Parts	16
Trouble Shooting	23
Warranty	24

## Unpacking / Inspection

Be sure to check the entire unit for any shipping damage or parts loss. Also note damage to the shipping cartons. Contact the transportation company for all damage and loss claims. The manufacturer is not responsible for damages in transit.

Small parts, needed to install the softener, are in a parts bag. To avoid loss of the small parts, keep them in the parts bag until you are ready to use them.

## Safety Guide

*For your safety, the information in this manual must be followed to minimize the risk of electric shock, property damage or personal injury.*

- Check and comply with your provincial / state and local codes. You must follow these guidelines.
- Use care when handling the filter tank. Do not turn upside down, drop, drag or set on sharp protrusions.
- The system works on 12 volt-60 Hz electrical power only. Be sure to use only the included transformer.
- Transformer must be plugged into an indoor 120 volt, grounded outlet only.
- **WARNING:** This system is not intended for treating water that is microbiologically unsafe or of unknown quality without adequate disinfection before or after the system.

## Proper Installation

*This water filter system must be properly installed and located in accordance with the Installation Instructions before it is used.*

- **Do not** install or store where it will not be exposed to temperatures below freezing or exposed to any type of weather. Water freezing in the system will break it. Do not attempt to treat water over 100°F.
- **Do not** install in direct sunlight. Excessive sun or heat may cause distortion or other damage to non-metallic parts.
- Properly ground to conform with all governing codes and ordinances.
- Use only *lead-free solder and flux* for all sweat-solder connections, as required by state and federal codes.
- Maximum allowable inlet water pressure is 125 psi. If daytime pressure is over 80 psi, night time pressure may exceed the maximum. Use a pressure reducing valve to reduce the flow if necessary.
- **WARNING:** Discard all unused parts and packaging material after installation. Small parts remaining after the installation could be a choke hazard.

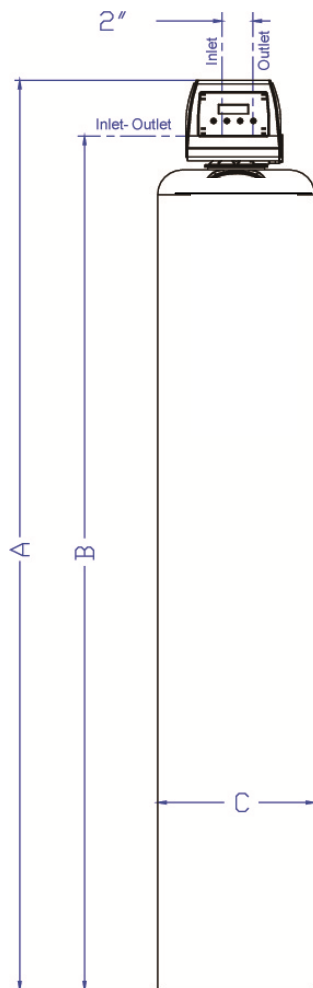

	A	B	C
0844	49.98"	46.54"	8"
0948	53.98"	50.54"	9"
1054	59.98"	56.54"	10"
1252	57.98"	54.54"	12"
1354	59.98"	56.54"	13"
1465	70.98"	67.54"	14"

## Specifications

Specifications	WG185ISF75	WG185ISF10	WG185ISF15	WG185ISF20	WG185ISF30
	2162	2163	2164	2165	2197
Normal Service Flow Rate	3.0 gpm	3.0 gpm	4.0 gpm	5.0 gpm	6.0 gpm
Peak Service Flow Rate	4.0 gpm	5.0 gpm	8.0 gpm	10.0 gpm	12.0 gpm
Backwash Flow Rate	3.5 gpm	4.0 gpm	5.0 gpm	7.0 gpm	10.0 gpm
Compensated Iron Removal Capacity	4,500 ppm	6,000 ppm	9,500 ppm	12,000 ppm	18,000 ppm
KMnO <sub>4</sub> per Regen	4 oz	4 oz	4 oz	8 oz	8 oz
Filter Media Volume - Cubic Feet	0.75 ft <sup>3</sup>	1.0 ft <sup>3</sup>	1.5 ft <sup>3</sup>	2.0 ft <sup>3</sup>	3.0 ft <sup>3</sup>
Filter Tank Size	8x44	9x48	10x54	12x52	14x65
Tank Jacket / Media Loaded	Yes	Yes	Yes	No	No
Shipping Weight	113 lbs	129 lbs	179 lbs	233 lbs	352 lbs
Maximum Combination of Iron X 1, Manganese X 2, H <sub>2</sub> S X3		10.0 ppm	Maximum Hydrogen Sulfide		3.0 ppm
Maximum Iron (Ferrous)		7.0 ppm	Maximum Manganese		5.0 ppm
Bacterial Iron		0.0 ppm	Minimum pH		7.0

- Continuous operation at flow rates greater than the service flow rate may affect capacity and efficiency performance.
- The manufacturer reserves the right to make product improvements which may deviate from the specifications and descriptions stated herein, without obligation to change previously manufactured products or to note the change.
- Peak flow rates are intended for intermittent use only and are for residential application only
- At the stated service flow rates, the pressure drop through these devices will not exceed 15 psig

The system consists of three major components: a back washable filter containing oxygen charged manganese greensand, a chemical feeder with shutoff float which delivers an accurately measured volume of potassium permanganate solution for each regeneration, and a meter initiated control valve which governs the operation of the system.

As water passes through the filter bed, it comes in contact with the oxygen charged media. This causes iron, manganese and sulfur to oxidize. The undesirable compounds are then trapped in the filter bed. Eventually the oxygen in the filter becomes depleted and regeneration is necessary. Regeneration takes place during the night while you sleep. First, backwashing cleans the filter bed, and then concentrated potassium permanganate solution is passed through it, recharging the bed with oxygen. A rapid rinse removes any remaining potassium and a volume of water is returned to the feeder to dissolve enough potassium permanganate for the next regeneration. All functions are performed automatically.

## Before Starting Installation

### Tools, Pipe, and Fittings, Other Materials

- Pliers
- Screwdriver
- Teflon tape
- Razor knife
- Two adjustable wrenches
- Additional tools may be required if modification to home plumbing is required.
- Plastic inlet and outlet fittings are included with the softener. To maintain full valve flow, 3/4" or 1" pipes to and from the softener fittings are recommended. You should maintain the same, or larger, pipe size as the water supply pipe, up to the softener inlet and outlet.
- Use copper, brass, or PEX pipe and fittings.
- Some codes may also allow PVC plastic pipe.
- ALWAYS install the included bypass valve, or 3 shut-off valves. Bypass valves let you turn off water to the softener for repairs if needed, but still have water in the house pipes.
- 5/8" OD drain line is needed for the valve drain. A 10' length of hose is included with some models.
- A length of 5/8" OD drain line tubing is needed for the brine tank over flow fitting (optional).
- Nugget or pellet water softener salt is needed to fill the cabinet or brine tank.

## Where To Install The Filter

- Place the filter tank as close as possible to the pressure tank (well system) or water meter (city water).
- Place the filter tank as close as possible to a floor drain, or other acceptable drain point (laundry tub, sump, standpipe, etc.).
- Connect the filter to the main water supply pipe BEFORE the water heater. **DO NOT RUN HOT WATER THROUGH THE FILTER.** Temperature of water passing through the filter must be less than 100 deg. F.
- Do not install the filter in a place where it could freeze. **Damage caused by freezing is not covered by the warranty.**
- Put the filter in a place water damage is least likely to occur if a leak develops. The manufacturer will not repair or pay for water damage.
- A 120 volt electric outlet, to plug the included transformer into, is needed within 6 feet of the filter. The transformer has an attached 6 foot power cable. **Be sure the electric outlet and transformer are in an inside location, to protect from wet weather.**
- If installing in an outside location, you must take the steps necessary to assure the filter, installation plumbing, wiring, etc., are as well protected from the elements, contamination, vandalism, etc., as when installed indoors.
- **Keep the filter out of direct sunlight.** The sun's heat may soften and distort plastic parts.

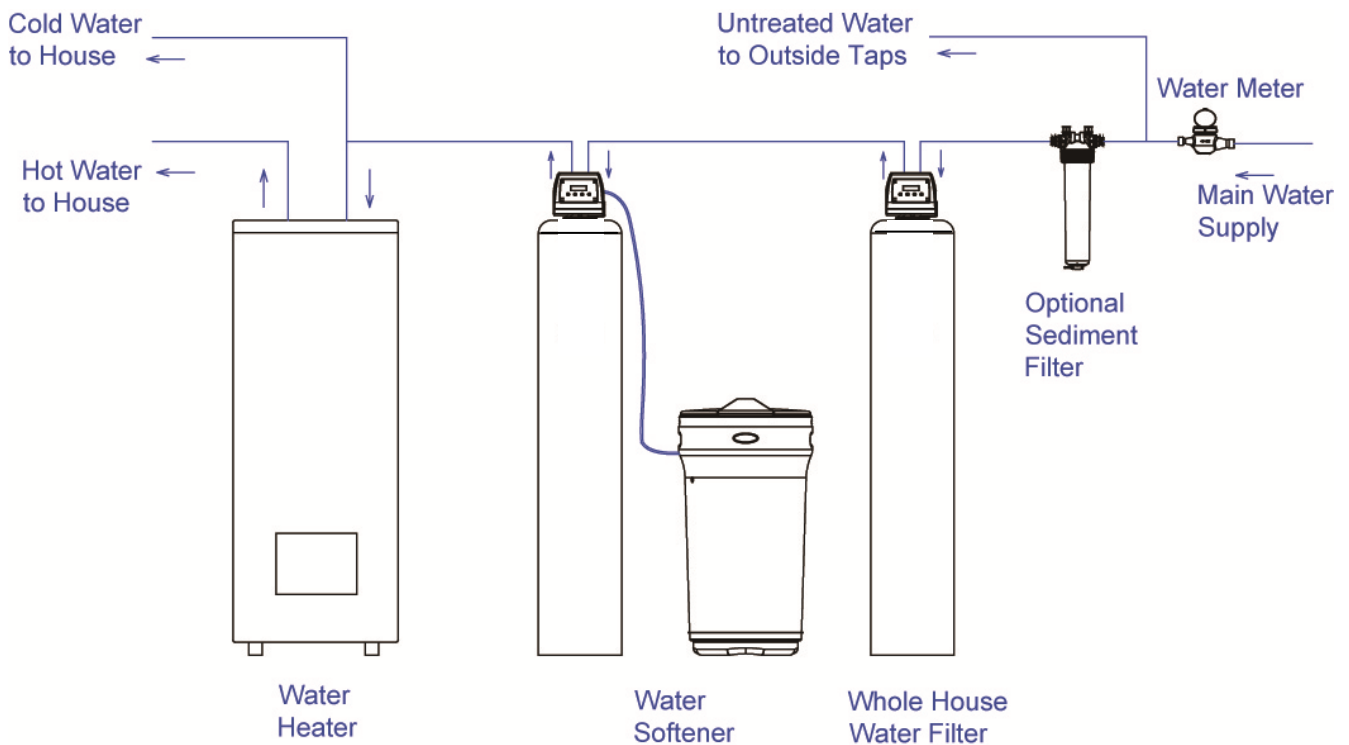

## Sizing Requirements

### Water Pressure

The water system must have a pump big enough to deliver the recommended backwash rate with a minimum pressure at the inlet of the filter of 30 psi. If the existing system cannot do this, it must be upgraded to do so. Whenever possible, the water system should be adjusted to deliver at least 30 psi for even more satisfactory results.

### Backwash Flow Rates

The most important criteria in sizing a filter is the capacity of the pump. The water must pass through the filter media at the proper service flow rate. The filter must also be backwashed at a flow rate sufficient to dislodge and remove the captured particles. Failure to provide sufficient water will cause a build-up of particles in the filter media, impairing its ability. In order for your filter to backwash and rinse properly, your pump must be capable of providing the backwash flow rates indicated on page 4.

### Check Your Pumping Rate

Two water system conditions must be checked carefully to avoid unsatisfactory operation or equipment damage:

1. Minimum water pressure required at the filter tank inlet is 20 psi.
2. Measuring the pumping rate of your pump:

With the pressure tank full, draw water into a container of known volume, and measure the number of gallons drawn until the pump starts again. This is draw-down. Divide this figure by cycle time and multiply the result by 60 to arrive at the pumping rate in gallons per minute (gpm). To aid in your calculation, insert the date in the following formula:

DRAW-DOWN \_\_\_\_\_ ÷ CYCLE TIME \_\_\_\_\_ x 60 = PUMPING RATE \_\_\_\_\_ (gals)  
(secs.) (Gpm)

EXAMPLE: CYCLE TIME is 53 seconds. DRAW-DOWN is 6 gallons; then, PUMPING RATE equals:

$$6 \text{ gallons} \div 53 \text{ seconds} \times 60 = 6.8 \text{ gpm}$$

See chart on page 4 for minimum flow rates.

NOTE: If your pumping rate is inadequate for the model, do not install your filter until the problem has been corrected.

## Capacity

An iron filter with one cubic foot of filter media regenerated with one Potassium Permanganate feeder will work well for most residential applications. For example, with iron in the range of 3-6 ppm, most filters will need to regenerate every two or three days providing an average family size of four or five people. The specification chart on page 4 shows the iron removal capacity in ppm that can be expected on automatic iron filters. The specifications are based on obtaining 6,000 ppm of capacity for each cubic foot of filter media. Two different Potassium Permanganate feeders are available – one feeding 2 oz. per regeneration, the other feeding 4 oz. In order to obtain the above capacities, the pH of the water being treated must be 7.0 or above. In the event the water is below 7.0, it must be treated with the appropriate equipment before going through the filter.

## Removal Of Iron, Manganese & Hydrogen Sulfide \*\*\*IMPORTANT\*\*\*

For the purpose of sizing a filter, consider 1 ppm of manganese equal to 2 ppm of iron and 1 ppm of hydrogen sulphide equal to 3 ppm of iron. Manganese and hydrogen sulphide (sulphur) are more difficult to oxidize than iron. Therefore, we suggest that, when making your sizing calculations and regeneration frequency calculations, calculate iron x 1, manganese x 2 and hydrogen sulphide x 3. All three must equal less than 10 ppm. Manganese is often present in water when iron is present. Hydrogen sulphide can normally be identified by a strong rotten egg odour.

## Installation Instructions

1. If your hot water tank is electric, turn off the power to it to avoid damage to the element in the tank.
2. If you have a private well, turn the power off to the pump and then shut off the main water shut off valve. If you have municipal water, simply shut off the main valve. Go to the faucet, (preferably on the lowest floor of the house) turn on the cold water until all pressure is relieved and the flow of water stops.
3. Locate the filter tank close to a drain where the system will be installed. The surface should be clean and level.
4. Connect the inlet and outlet of the filter using appropriate fittings. Perform all plumbing according to local plumbing codes.
  - Use a ½" minimum pipe or tubing size for the drain line
  - **ON COPPER PLUMBING SYSTEMS BE SURE TO INSTALL A GROUNDING WIRE BETWEEN THE INLET AND OUTLET PIPING TO MAINTAIN GROUNDING.**

Any solder joints near the valve must be done before connecting any piping to the valve. Always leave at least 6" (152 mm) between the valve and joints when soldering pipes that are connected to the valve. Failure to do this could cause damage to the valve.



5. Connect the drain hose (10 ft included) to the valve and secure it with a hose clamp (also included). Run the drain hose to the nearest laundry tub or drain pipe. This can be ran up overhead or down along the floor. If running the drain line more than 20 ft overhead, it is recommended to increase the hose size to 3/4". NEVER MAKE A DIRECT CONNECTION INTO A WASTE DRAIN. A PHYSICAL AIR GAP OF AT LEAST 1.5" SHOULD BE USED TO AVOID BACTERIA AND WASTEWATER TRAVELLING BACK THROUGH THE DRAIN LINE INTO THE FILTER.
6. Connect the 3/8" tubing from the chemical feed tank to the valve.
7. Attach the 5/8" hose (supplied) to the over flow fitting on the feeder and run the hose to the floor drain.
8. Add water until there is approximately 1" (25 mm) of water above the grid plate. Do not add any chemical to the tank at this time.
9. Using the Allen Key (included), place the unit in the bypass position. Slowly turn on the main water supply. At the nearest cold treated water tap nearby remove the faucet screen, open the faucet and let water run a few minutes or until the system is free of any air or foreign material resulting from the plumbing work.
10. Make sure there are no leaks in the plumbing system before proceeding. Close the water tap when water runs clean.
11. Proceed to start up instructions.

**Note:** *The unit is not ready for service until you complete the start-up instructions.*

## System Start-Up

### Key Pad Configuration

SETTINGS	This function is to enter the basic set up information required at the time of installation.
MANUAL REGEN	This function is to initiate an immediate or delayed manual regeneration.
DOWN / UP	Increase or decrease the value of the settings while in the programming mode.



## **Manual Regeneration (Step / Cycle Valve)**

### **DELAYED REGENERATION**

Press and release the MANUAL REGEN. Button to set a delayed regeneration that will occur at the regeneration time. The main display page will show DELAYED REGEN ON. To cancel press and release the MANUAL REGEN. Button. The main display page will show DELAYED REGEN OFF.

### **IMMEDIATE REGENERATION**

To start an immediate regeneration (or step valve through each position), press and hold the MANUAL REGEN. Button for 3 seconds (until beeps). The valve will start an immediate regeneration. Press any key to skip to the next cycle.

### **Start-up Instructions**

1. Plug the power transformer into an approved power source. Connect the power cord to the valve.
2. When power is supplied to the control, the screen will display "INITIALIZING WAIT PLEASE" while it finds the service position.
3. Start an Immediate Manual Regeneration. The valve will immediately start moving to the BACKWASH position.
4. Once in the BACKWASH cycle, open the inlet on the bypass valve slowly and allow water to enter the unit. Allow all air to escape from the unit before turning the water on fully then allow water to run to drain for 3-4 minutes or until all media fines are washed out of the softener indicated by clear water in the drain hose.
5. Press any button to advance to the CHEM-DRAW position. Check the water level in the chemical feed tank to insure the valve is drawing water properly.
6. Press any button and advance to the RINSE position. Check the drain line flow. Allow the water to run for 3-4 minutes or until the water is clear.
7. Press any button to advance to the REFILL position. Check that the valve is filling water into the chemical tank. Allow the valve to refill until the float shuts off the water flow to the tank.
8. The valve will automatically advance to the SERVICE position. Open the outlet valve on the bypass, then open the nearest treated water faucet and allow the water to run until clear, close the tap and replace the faucet screen.
9. Cautiously pour Potassium Permanganate into the chemical tank. Replace the cover and the safety screws.
10. Manually initiate a regeneration after about one hour (time for the chemical to dissolve) to activate the manganese greensand.
11. Program unit.

## Plumbing System Clean-Up

The following procedures are guidelines only but have proven successful in most instances. Under no circumstances should any procedure outlined below be followed if contrary to the appliance manufacturer's instructions. Should there be any questions concerning the advisability of performing a procedure, it is strongly recommended the manufacturer's authorized service outlet be consulted prior to performing the procedure.

The plumbing system and water using appliances that have been exposed, even for a

short time, to iron-fouled water need to be cleaned of the precipitated iron that has collected in them or iron bleed (staining) will continue to be a problem.

Depending on the amount of iron in the water and the length of time the water system has been exposed to iron fouling, select from the following procedures those that apply to the type of system and appliances that need to be cleaned to assure iron-free water at all points of use.

### **Softener**

It isn't uncommon that the softener was installed in an effort to remove ferrous (clear water) iron from the water supply. Typically a softener will remove some ferrous iron until the resin bed becomes fouled to the extent that it will lose both hardness removal capacity and the limited capacity for iron removal. This is the condition to expect the softener to be in when planning a system clean-up. Prior to closing the main supply valve or turning power off to a private well system and preparatory to installing the filter system, do the following:

1. Disconnect the brine draw line from the brine cabinet and place the loose end into a five gallon plastic pail filled with a solution of warm water and 4 oz. of resin mineral cleaner.
2. Advance the control timer to the brine draw position (refer to instructions provided with your softener). Allow all the

warm mineral cleaner solution to be drawn into the mineral bed.

3. Then immediately close the main water supply valve or turn the power off to the pump and proceed with the filter installation. During the time required to install the filter system, the iron-fouled softener resin will be chemically cleaned.
4. After the filter installation is completed and final adjustments have been made, with the water turned on and the brine draw tube reconnected, reposition the timer on the softener to the backwash position. Allow the timer to perform an automatic regeneration cycle. During backwash of the softener, all iron cleaned from the resin will be washed down the drain. It is advisable, after chemically cleaning the softener, to regenerate the system twice to fully restore capacity lost due to iron-fouling.

## Water Heater

If the water heater has been exposed to both iron and hardness for a long period of time, replacement of the heater tank may be the only practical solution to prevent continued staining originating from this source. After completing the installation of the chemical free iron filter, clean the water heater by following these instructions:

1. Shut off the energy supply to the water heater and close the heater inlet water valve.
2. Drain hot water tank completely. Open inlet water valve, allowing heater tank to be refilled with iron-free water. Continue

flushing until the water runs clear to the drain.

3. If, after approximately 30 minutes of flushing, water does not clear, terminate the flushing operation. Refill hot water heater with water and pour approximately 1/2 gallon of household bleach into the top of the heater tank. Allow bleach solution to stand in tank for 20 to 30 minutes. Flush the tank again until water is clear at the drain. Turn energy supply on.

NOTE: If water does not clear in approximately 10 minutes, water heater should probably be replaced.

## Programming Instructions

### Settings

Press SETTINGS key (3 SECONDS / BEEP)

**VALVE MODE**  
GREENSAND

**TIME OF DAY**  
12:01 PM

**YEAR**  
2012

**MONTH**  
AUGUST

**DAY**  
21

**REGEN DAYS**  
3 DAYS

**GALLONS**  
OFF

**REGEN TIME**  
12:00 AM

**PROGRAMMING**  
COMPLETE

### TIME OF DAY, YEAR, MONTH, DAY,

Time of day is for normal operation of system and the scheduling of the regeneration time. The date is used in a diagnostic function to track the last time the system regenerated.

### REGEN DAYS

This value is the number of days between regenerations or back washes to clean the filters.

### GALLONS

Default value is OFF. Adjust the GALLONS to set the capacity. This will cause the unit to regenerate either when the gallons remaining goes to zero or the days between regeneration is zero. Which ever occurs first.

### REGEN TIME

This setting determines the time of day to perform a scheduled regeneration. The normal regen time for a filter is 12:00 AM.

## About The System

### Control Operation During A Power Failure

In the event of a power failure, the valve will keep track of the time and day for 48 hours. The programmed settings are stored in a non-volatile memory and will not be lost during a power failure. If power fails while the unit is in regeneration, the valve will finish regeneration from the point it is at once power is restored. If the valve misses a scheduled regeneration due to a power failure, it will queue a regeneration at the next regeneration time once power is restored.

### Main Display

The main display page will pause on the Date and Time page for 5 seconds. Then it will continually scroll through all of the system diagnostic display pages. Depending on the Valve Type some pages will not be displayed. To manually scroll through the diagnostics, press the down or up key. To reset the TOTAL REGENS, TOTAL GALLONS OVER RUN TOTAL, or PEAK flow rates, press and hold the MENU until the value changes to zero.

PARAMETER	DESCRIPTION
JULY/17/2012 8:30 PM	Month, Day, Year, Time
TOTAL 1,500 GAL REMAIN 1,200 GAL	The total amount is the system capacity when fully regenerated. The remaining is the capacity left in the system.
PEOPLE 2 RESERVE 150 GAL	Number of people in the household and the calculated reserve capacity. When remaining reaches reserve capacity a regeneration will be scheduled.
EST. DAYS TO NEXT REGEN 06 DAYS	The estimated number of days until the next regeneration will occur.
LAST REGEN 9/24/12	The date of the last regeneration.
TOTAL REGENS 10	The total number of regenerations.
TOTAL GALLONS 001590 GAL	The total amount of gallons treated by the system.
OVER RUN TOTAL 0500 GAL	The total amount of water that has exceeded the system capacity over the last 4 regenerations. When remaining goes to zero, the gallons used will be added to over run total.
CURRENT 1.5 GPM PEAK 6.5 GPM	The current flow rate and the peak flow rate since the last regeneration.
DELAYED REGEN OFF	Advises whether a delayed regeneration has been scheduled manually or automatically.
REGEN TIME 2:00 AM	The current setting for regeneration time.
REFILL TIME 3:00 MIN	The current calculated refill time.
VALVE MODE SOFTENER UF	The current setting of the valve mode.

### New Sounds

You may notice new sounds as your water softener operates. The regeneration cycle lasts up to 180 minutes. During this time, you may hear water running intermittently to the drain.

## **Regeneration Process**

When the system capacity is near exhausted, a regeneration is necessary to restore the system to full capacity. The table below explains the regeneration steps.

Step	Name	Description
#1	Back Wash	Fresh water is introduced to the bottom of the tank flowing upwards expanding the ion exchange resin to rinse out any dirt or small particles to the drain and to un-compact the bed to restore full service flow rates.
#2	Chem-Draw	The chemical solution is introduced slowly to the top of the tank flowing down through the filter bed restoring system capacity.
#3	Rinse	Fresh water is introduced from the top of the tank down flowing down through the ion exchange resin rinsing any excess brine solution out to the drain.
#4	Refill	Filtered water is added to the chemical tank until the safety float in the tank shuts off the flow of water. The water will mix with the chemicals to become saturated for the next regeneration.

## **Automatic Raw Water Bypass During Regeneration**

The regeneration cycle can last 30 to 180 minutes, after which soft water service will be restored. During regeneration, raw water is automatically bypassed for use in the household. Hot water should be used as little as possible during this time to prevent raw water from filling the water heater. This is why automatic regeneration is set for sometime during the night and manual regenerations should be performed when little or no water will be used in the household.

Normal regeneration time is 12:00 AM.

## **System Configuration**

<b>Suggested Iron Filter Valve Configuration</b>			
Tank Size (Diameter)	Injector	Brine Line Flow Control (BLFC)	Drain Line Flow Control (DLFC)
8"	#2 GREY (PVC)	(0.70 GPM)	#5 (3.5 GPM)
9"			#A (5.0 GPM)
10"			#A (5.0 GPM)
12"			#B (7.0 GPM)
14"			#C (10.0 GPM)

## **Manual Bypass**

In the case of emergency, such as an overflowing brine tank, you can isolate your water softener from the water supply using the bypass valve located at the back of the control. In normal operation the bypass is open with the on/off knobs in line with the inlet and outlet pipes.

To isolate the softener, simply rotate the knobs clockwise (as indicated by the word BYPASS and arrow) until they lock. You can use your water related fixtures and appliances as the water supply is bypassing the softener. However, the water you use will be hard. To resume soft water service, open bypass valve by rotating the knobs counterclockwise.

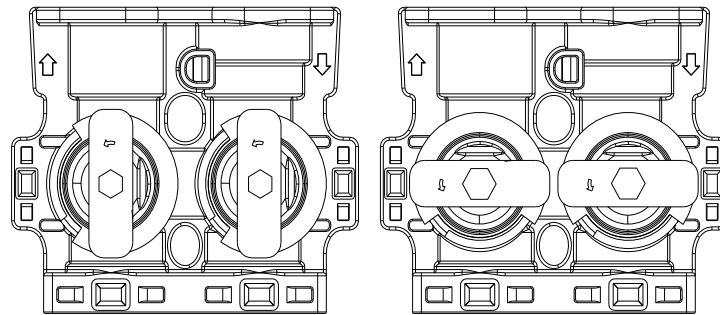

SERVICE POSITION

BYPASS POSITION

## Maintenance

### **Adding Salt**

Use only crystal water softener salt. Check the salt level monthly. It is important to maintain the salt level above the water level. To add salt, simply lift the salt lid and add the salt directly into the brine tank. Be sure the brine well cover is on and fill only to the height of the brine well.

### **Bridging**

Humidity or wrong type of salt may create a cavity between the water and the salt. This action, known as "bridging", prevents the brine solution from being made, leading to your water supply being hard.

If you suspect salt bridging, carefully pound on the outside of the brine tank or pour some warm water over the salt to break up the bridge. This should always be followed up by allowing the unit to use up any remaining salt and then thoroughly cleaning out the brine tank. Allow two hours to produce a brine solution, then manually regenerate the softener.

## Cleaning or Replacing Injectors

Sediment, salt and silt will restrict or clog the injector. A clean water supply and pure salt will prevent this from happening.

The injector assembly is located on the right side of the control valve. This assembly is easy to clean.

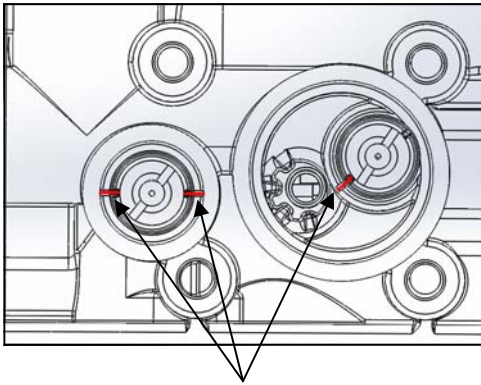

TIP: There are marks on the injector holder that must be lined up to the marks on the valve to fully insert the holder into the hole in the valve body

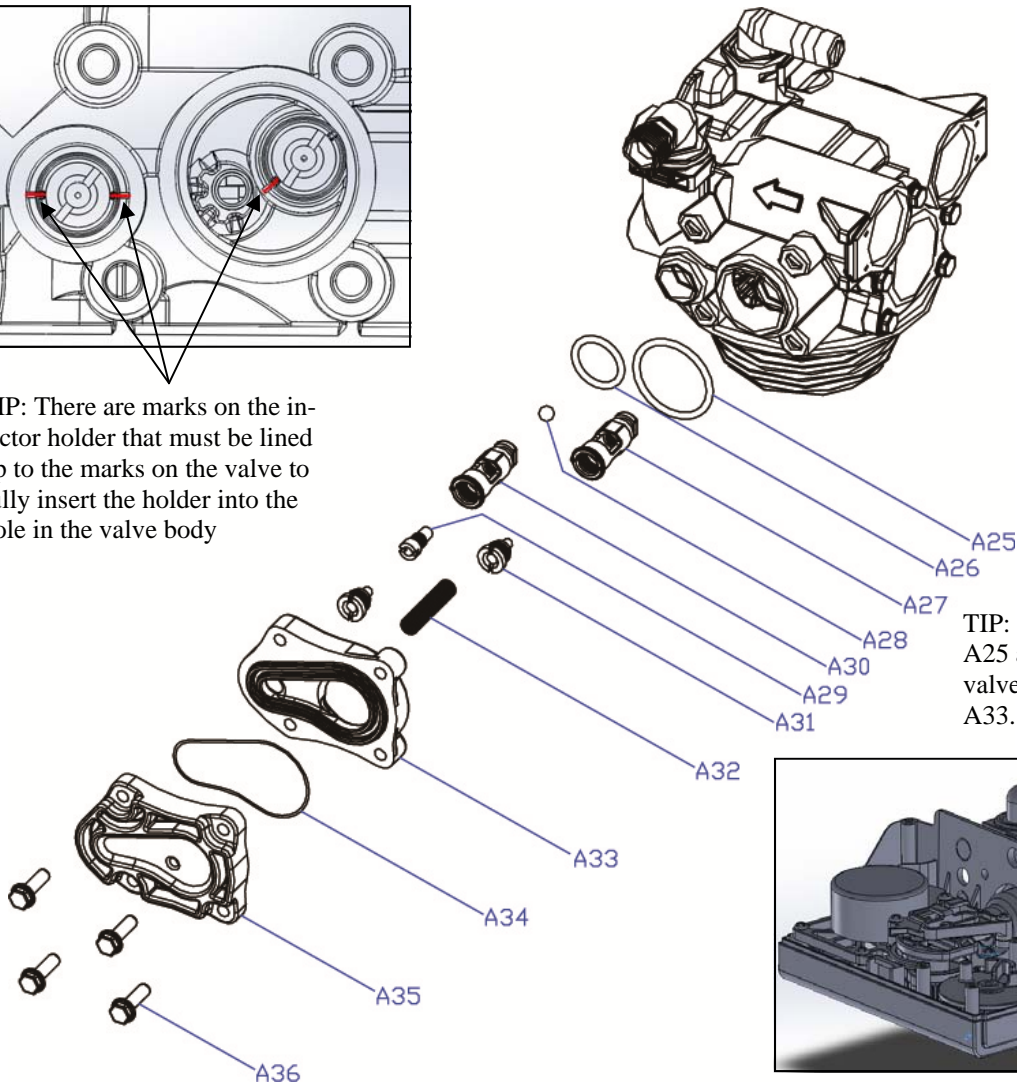

TIP: Place the o-rings A25 and A26 onto the valve before installing A33.

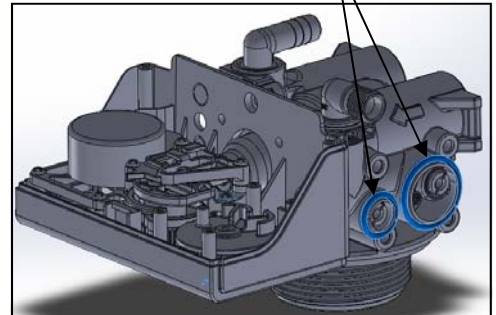

1. Shut off the water supply to your filter and reduce the pressure by opening a cold soft water faucet.
2. Using a screwdriver, remove the four screws holding the injector cover to the control valve body.
3. Carefully remove the assembly and disassemble as shown in above figure.
4. The injector orifice is removed from the valve body by carefully turning it out with a large screwdriver. Remove the injector throat the same way.
5. Carefully flush all parts including the screen. Use a mild acid such as vinegar or Pro-Rust Out to clean the small holes in the orifice and throat.
6. Reassemble using the reverse procedure.



## **Replacing Brine Line Flow Control (BLFC)**

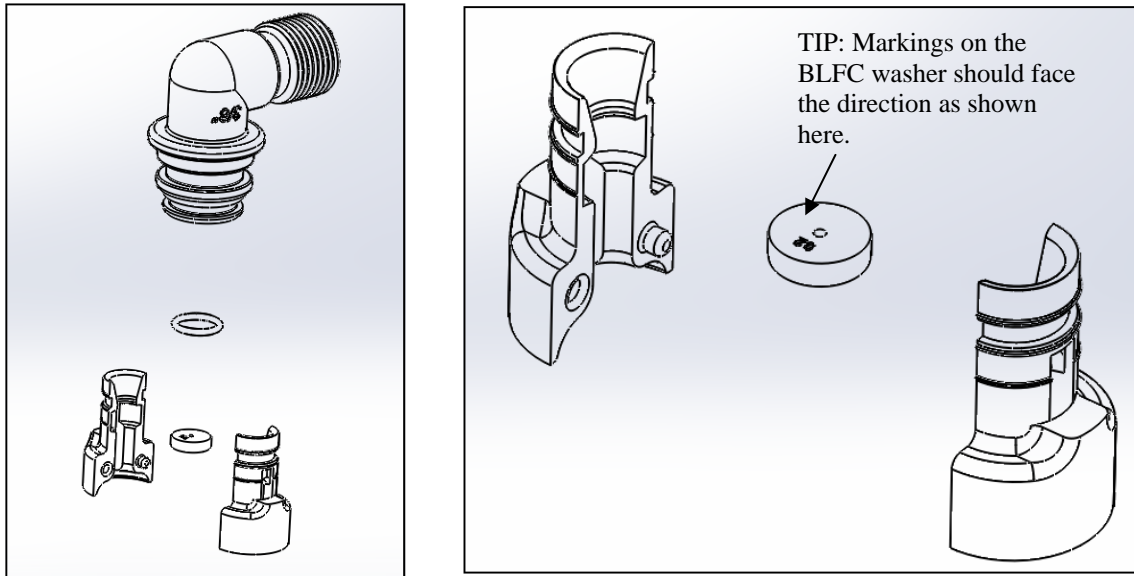

1. Remove the red clip that secures the brine elbow.
2. Remove the BLFC holder from the elbow fitting.
3. Split the BLFC holder apart and remove the flow washer.
4. Reassemble using the reverse procedure.

## **Replacing Drain Line Flow Control (DLFC)**

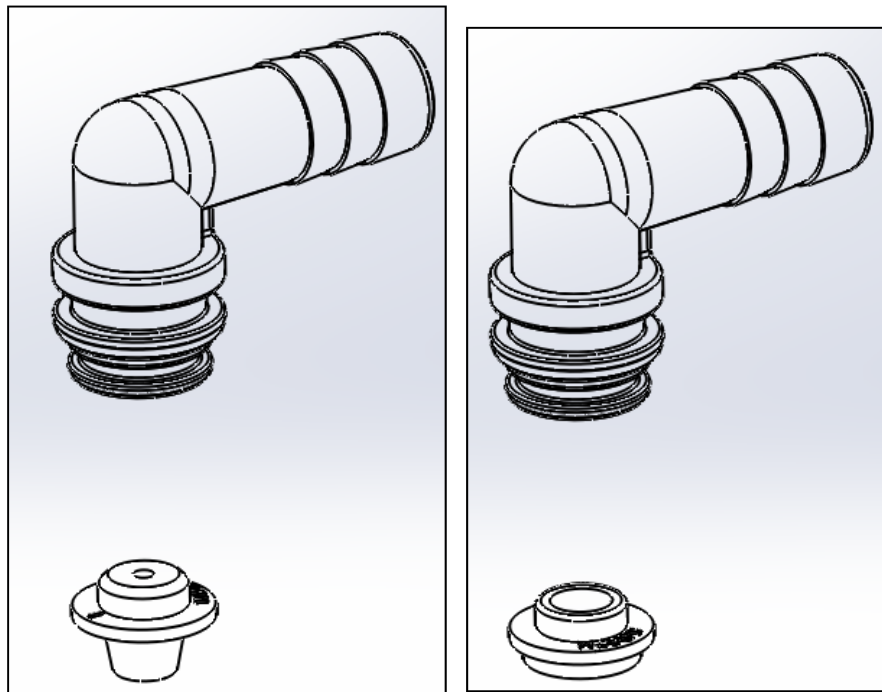

1. Remove the red clip that secures the drain line elbow.
2. Remove the BLFC washer from the elbow fitting.
3. Reassemble using the reverse procedure.

# Main Repair Parts

## Main Repair Parts - Connectors

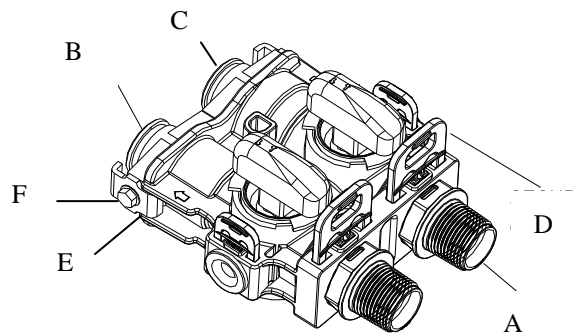
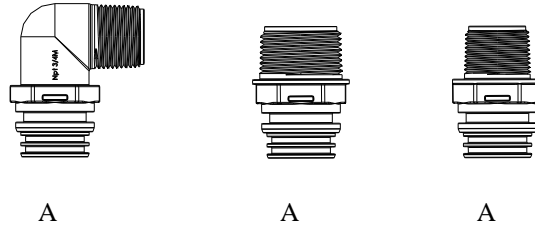

REPLACEMENT PARTS - CONNECTORS			
Replacement Part Number	Part Description	DWG #	Quantity
60010020	3/4" NPT ELBOW	A	2
60010019	1" NPT STRAIGHT	A	2
60010023	3/4" NPT STRAIGHT	A	2
60010079	VALVE COUPLING INLET	B	1
60010101	VALVE COUPLING OUTLET (METER SIDE)	C	1
60010025	PLASTIC SECURE CLIP	D	2
60010046	BYPASS SS CLIP	E	2
60010047	BYPASS SS SCREW	F	2

## Control Valve Exploded View

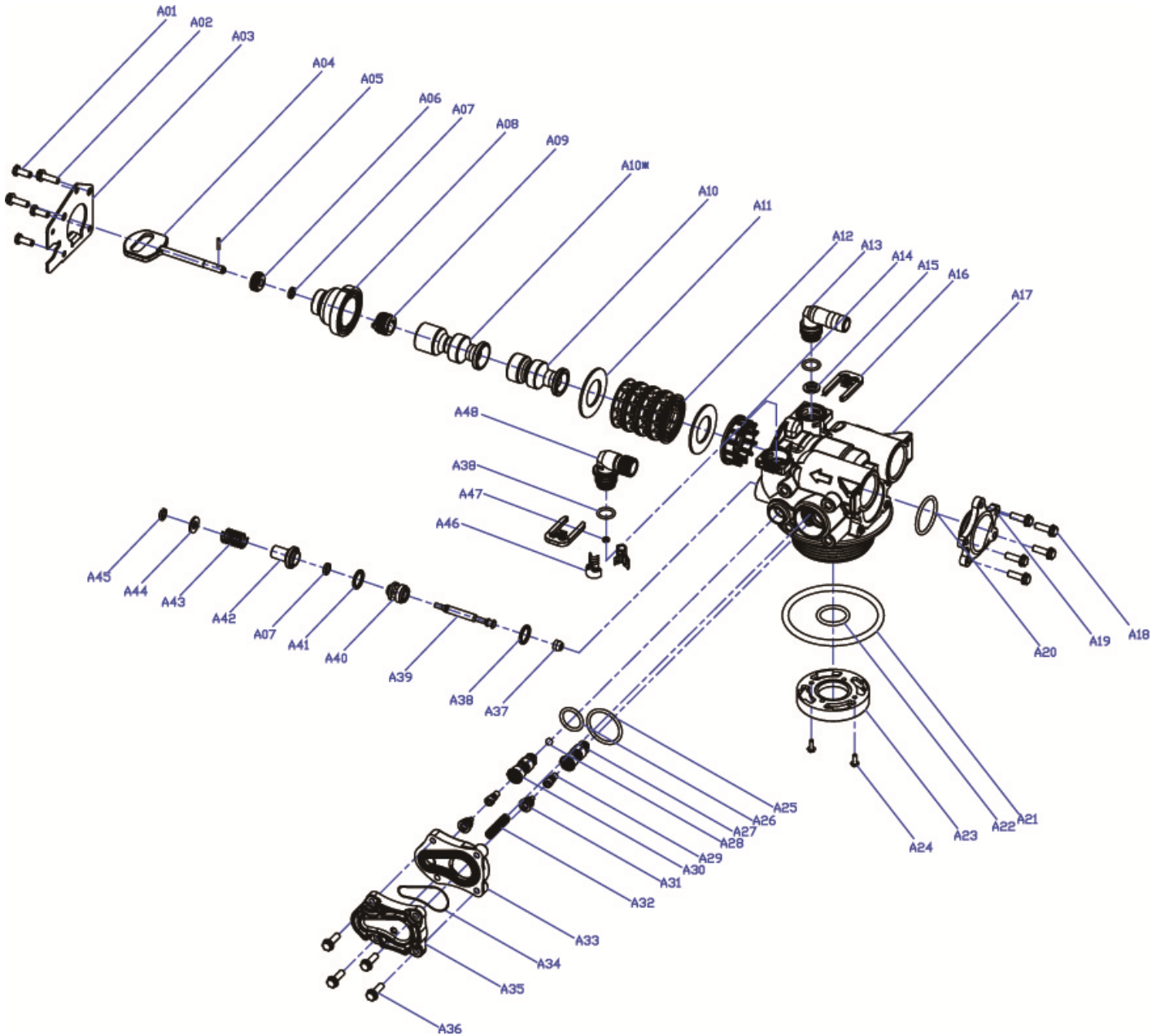

VALVE REPAIR PARTS LIST			
Replacement Part Number	Part Description	Replacement Part Number	Part Description
60010127	INJECTOR SET #0000 BLACK	60010129	85HE UPFLOW PISTON ASSEMBLY
60010126	INJECTOR SET #000 GREY	60010171	85HE DOWNFLOW PISTON ASSEMBLY
60010035	INJECTOR SET #00 VIOLET	60010130	85HE SEAL & SPACER KIT
60010034	INJECTOR SET #0 RED	60010131	85HE DLFC #1 1.5 GPM
60010033	INJECTOR SET #1 WHITE	60010132	85HE DLFC #2 2.0 GPM
60010032	INJECTOR SET #2 BLUE	60010133	85HE DLFC #3 2.4 GPM
60010031	INJECTOR SET #3 YELLOW	60010135	85HE DLFC #5 3.5 GPM
60010128	BLFC 0.2 GPM	60010136	85HE DLFC #A 5.0 GPM
60010110	BLFC 0.3 GPM	60010137	85HE DLFC #B 7.0 GPM
60010082	BLFC 0.7 GPM	60010138	85HE DLFC #C 10.0 GPM

## Control Valve Parts List

185HE CONTROL VALVE (DOWNFLOW)				
Replacement Part Number	MFG Part Number	Part Description	DWG #	Quantity
	5056087	Screw-M5x12(Hexagon)	A01	3
	5056088	Screw-M5x16(Hexagon With Washer)	A02	2
	5056047	End Plug Retainer	A03	1
	5031016	BNT85HE Piston Rod	A04	1
	5056097	Piston Pin	A05	1
	5031015	BNT85HE Quad Ring Plug Cover	A06	1
	5056070	Quad Ring	A07	2
	5031011	BNT85HE End Plug	A08	1
	5031014	BNT85HE Piston Retainer	A09	1
	5057001	BNT85HE Piston(Electrical Downflow)	A10	1
	5056073	Seal	A11	5
	5056021	Spacer	A12	4
	5010082	Drain Fitting-B	A13	1
	5031005	BNT85HE Spacer	A14	1
	5056186	DLFC-2#	A15	1
	5056172	Secure Clip-s	A16	2
	5031002	BNT85HE Valve Body	A17	1
	5056508	Screw-M5x12(Hexagon With Washer)	A18	5
	5030004	BNT85 End Cover	A19	1
	5030013	O-Ring- $\phi$ 30x2.65	A20	1
	5056063	O-Ring- $\phi$ 78.74x5.33	A21	1
	26010103	O-Ring- $\phi$ 25x3.55	A22	1
	7060007	Valve Bottom Connector	A23	1
	13000426	Screw-ST2.9X13(Large Washer)	A24	2
	5031022	O-Ring- $\phi$ 32x3	A25	1
	5031021	O-Ring- $\phi$ 18x3	A26	1
	5031013	Injector Plug Body	A27	1
	30110007	Plastic Ball $\phi$ 6	A28	1
	30040089	Injector Throat	A29	2
	5031012	BNT85HE Injector Fixed Sleeve	A30	1
	30040090	Injector Nozzle	A31	2
	5056103	Injector Screen	A32	1
	5031003	BNT85HE Injector Cover Body	A33	1
	5031018	O-Ring- $\phi$ 40x2.65	A34	1
	5031004	BNT85HE Injector Cover Cap	A35	1
	5031027	Screw-M5x25(Hexagon With Washer)	A36	4
	5056075	Seal Mat	A37	1
	5056134	O-Ring- $\phi$ 12x2	A38	3
	5056054	Injector Stem	A39	1
	5056031	Injector Spacer	A40	1
	5056081	O-Ring- $\phi$ 12.5x1.8	A41	1
	5056030	Injector Cap	A42	1
	5056093	Injector Screen	A43	1
	5010049	Special Washer	A44	1
	5056105	Retaining Ring	A45	1
	5031010	BNT85HE BLFC Fixed Sleeve	A46	2
	5056076	BLFC-2#	A47	1
	5005629	Injector Fitting(3/8".Elbow)	A48	1

# Power Head Exploded View

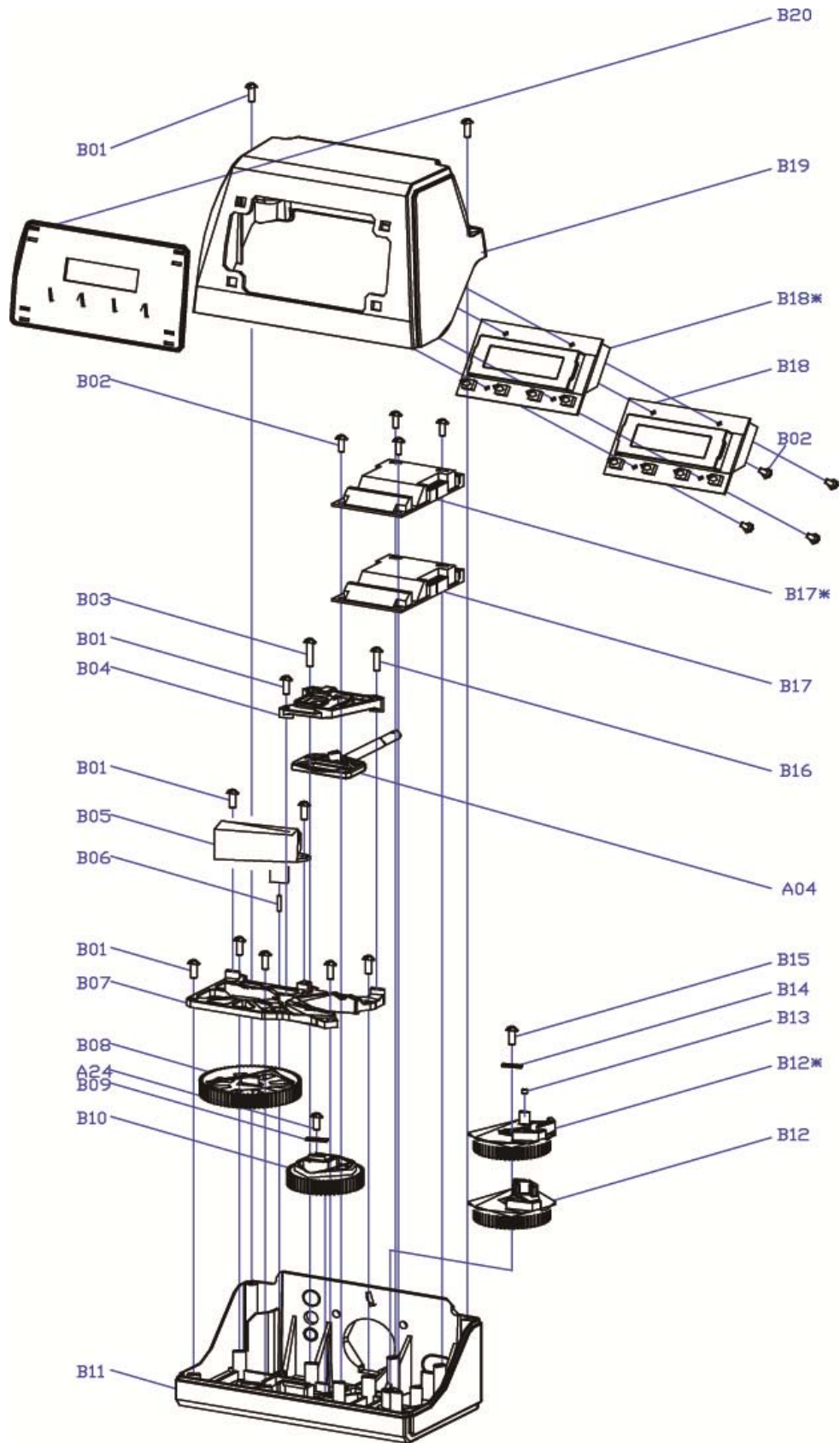

## Power Head Parts List

185HE POWER HEAD (DOWNFLOW)				
Replacement Part Number	MFG Part Number	Part Description	DWG #	Quantity
	5056084	Screw-ST3.5X13	B01	10
	5010037	Screw-ST2.9X10	B02	9
	13000416	Screw-ST3.5X25	B03	1
	5031007	BNT85HE Piston Rod Guide Plate	B04	1
	5056510	Motor-12v/2rpm	B05	1
	5030014	Motor Power Cable		1
	11700005	Wire Connector		2
	5056098	Motor Pin	B06	1
	5031006	BNT85HE Mounting Plate	B07	1
	5030009	BNT85 Drive Gear	B08	1
	13000426	Screw-ST2.9X13(Large Washer)	A24	2
	5056139	Washer-3x13	B09	1
	5030007	BNT85 Main Gear	B10	1
	5030005	BNT185 Housing	B11	1
	5031017	BNT85HE Brine Gear(Downflow)	B12	1
	5010023	Magnet(3x2.7)	B13	1
	5056141	Washer-4x12	B14	1
	5056166	Screw-ST4.2X12(Large Washer)	B15	1
	5031016	BNT85HE Piston Rod	A04	1
	5010036	Screw-ST3.5X16	B16	1
	5031026	BNT85HE Main Pcb(Downflow)	B17	1
	5010031	Meter Assembly		1
	5010046	Meter Strain Relief		1
	5010029	Power Cable		1
	5010035	Power Strain Relief		1
	19010105	Wire Rope-3x100		2
	5031024	BNT85HE Display(Downflow)	B18	1
	5030021	BNT85 Wiring Harness		1
	5030003	BNT85 Cover	B19	1

## Trouble Shooting

Issue	Possible Cause	Possible Solution
A. Unit fails to initiate a regeneration cycle.	1. No power supply.	Check electrical service, fuse, etc.
	2. Defective circuit board.	Replace faulty parts.
	3. Power failure.	Reset time of day.
B. Water is red.	1. By-pass valve open.	Close by-pass valve.
	2. Out of KMnO <sub>4</sub> .	Add to tank.
	3. Plugged injector / screen.	Clean parts.
	4. Flow of water blocked to chemical tank.	Check for flow to tank.
	5. Rusty water in how water tank. Sediment in tank disturbed.	Repeat flushing of hot water tank required.
	6. Leak between valve and central tube.	Check if central tube is cracked or o-ring is damaged. Replace faulty parts.
	7. Internal valve leak.	Replace valve seals, spacer, and piston
C. Chemical use is high.	1. Defective chemical tank system.	Replace chemical tank.
D. Low water pressure.	1. Iron or scale build up in line	Clean pipes.
	2. Iron build up inside valve or tank.	Clean control and add resin cleaner to clean bed. Increase regeneration frequency.
	3. Inlet of control plugged due to foreign material.	Remove piston and clean control valve.
E. Filter media in drain line.	1. Air in water system.	Check well system for proper air eliminator control.
	2. Incorrect drain line flow control (DLFC) button.	Check for proper flow rate.
F. Too much water in brine tank.	1. Plugged injector or screen.	Clean parts.
	2. Valve not regenerating.	Replace circuit board, motor, or control.
	3. Foreign material in brine valve.	Clean parts.
G. Unit fails to draw regenerate chemicals.	1. Drain line flow control is plugged.	Clean parts.
	2. Injector or screen is plugged.	Clean parts.
	3. Inlet pressure too low.	Increase pressure to 25 PSI.
	4. Internal valve leak.	Replace seals, spacers, and piston assembly.
H. Valve continuously cycles.	1. Defective position sensor PCB.	Replace faulty parts.
I. Flow to drain continuously.	1. Valve settings incorrect.	Check valve settings.
	2. Foreign material in control valve.	Clean control.
	3. Internal leak.	Replace seals, spacers, and piston
J. Pink color in water. Chemical taste.	1. Poor water pressure.	Be sure pump is set to min. 20 psi and is capable of proper flow rate for filter system.
	2. Chemical in supply line.	Decrease frequency of regeneration cycles.

## Warranty

**WaterGroup** warrants that your new water conditioner is built of quality material and workmanship. When properly installed and maintained, it will give years of trouble free service.

### **Seven Year Complete Parts Guarantee**

**WaterGroup** will replace any part which fails within 84 months from date of manufacture, as indicated by the serial number, provided the failure is due to a defect in material or workmanship. The only exception shall be when proof of purchase or installation is provided and then the warranty period shall be from the date thereof.

### **Life Time Warranty on Mineral Tanks and Brine Tanks**

WaterGroup will provide a replacement mineral tank or brine tank to any original equipment purchaser in possession of a tank that fails provided that the water conditioner is at all times operated in accordance with specifications and not subject to freezing.

### **General Provisions**

WaterGroup assumes no responsibility for consequential damage, labour or expense incurred as a result of a defect or for failure to meet the terms of these guarantees because of circumstances beyond its control.