

185DF Backwashing Filters
Carbon—Taste and Odor(ACF)
Multimedia (MMF)
NextSand (ULTRAMF)
Neutralizer (NNF)



Owners Manual

FOLLOW THE INSTALLATION INSTRUCTIONS CAREFULLY. FAILURE TO INSTALL THE UNIT PROPERLY VOIDS THE WARRANTY. BEFORE YOU BEGIN INSTALLATION, READ THIS ENTIRE MANUAL. THEN, OBTAIN ALL THE MATERIALS AND TOOLS

1. **Avoid pinched o-rings during installation by applying (provided with install kit) NSF certified lubricant to all seals.**
2. **This system is not intended for treating water that is microbiologically unsafe or of unknown quality without adequate disinfection before or after the system.**

Table of Contents

	PAGE
Unpacking / Inspection	2
Safety Guide	2
Proper Installation	3
Specification	4
Before Starting Installation	5
Sizing Requirements	7
Installation Instructions	8
System Start Up	10
About The System	12
Maintenance	14
Main Repair Parts	16
Trouble Shooting	23
Warranty	24

Unpacking / Inspection

Be sure to check the entire unit for any shipping damage or parts loss. Also note damage to the shipping cartons. Contact the transportation company for all damage and loss claims. The manufacturer is not responsible for damages in transit.

Small parts, needed to install the softener, are in a parts bag. To avoid loss of the small parts, keep them in the parts bag until you are ready to use them.

Safety Guide

For your safety, the information in this manual must be followed to minimize the risk of electric shock, property damage or personal injury.

- Check and comply with your provincial / state and local codes. You must follow these guidelines.
- Use care when handling the filter tank. Do not turn upside down, drop, drag or set on sharp protrusions.
- The system works on 12 volt-60 Hz electrical power only. Be sure to use only the included transformer.
- Transformer must be plugged into an indoor 120 volt, grounded outlet only.
- **WARNING:** This system is not intended for treating water that is microbiologically unsafe or of unknown quality without adequate disinfection before or after the system.

Proper Installation

This water filter system must be properly installed and located in accordance with the Installation Instructions before it is used.

- **Do not** install or store where it will not be exposed to temperatures below freezing or exposed to any type of weather. Water freezing in the system will break it. Do not attempt to treat water over 100°F.
- **Do not** install in direct sunlight. Excessive sun or heat may cause distortion or other damage to non-metallic parts.
- Properly ground to conform with all governing codes and ordinances.
- Use only *lead-free solder and flux* for all sweat-solder connections, as required by state and federal codes.
- Maximum allowable inlet water pressure is 125 psi. If daytime pressure is over 80 psi, night time pressure may exceed the maximum. Use a pressure reducing valve to reduce the flow if necessary.
- **WARNING:** Discard all unused parts and packaging material after installation. Small parts remaining after the installation could be a choke hazard.

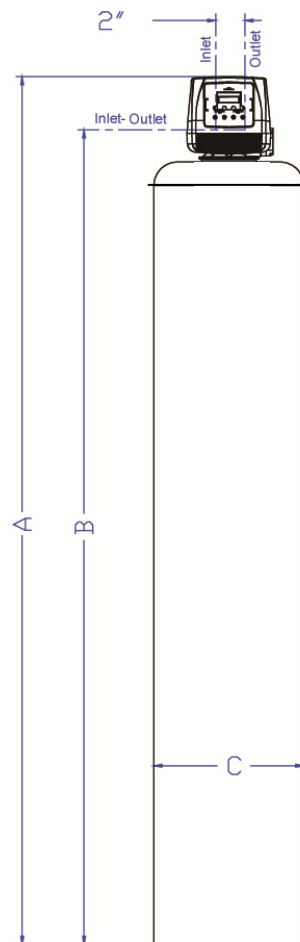

	A	B	C
0844	49.98"	46.54"	8"
0948	53.98"	50.54"	9"
1054	59.98"	56.54"	10"
1252	57.98"	54.54"	12"
1354	59.98"	56.54"	13"
1465	70.98"	67.54"	14"

Specifications

Specifications	WG185ACF75	WG185ACF10	WG185ACF15	WG185ACF20	WG185ACF30
	2150	2151	2152	2153	2220
Normal Service Flow Rate	4.0 gpm	5.0 gpm	7.0 gpm	10 gpm	12.0 gpm
Peak Service Flow Rate	5.0 gpm	7.0 gpm	10.0 gpm	12.0 gpm	15.0 gpm
Backwash Flow Rate	3.5 gpm	4.0 gpm	5.0 gpm	7.0 gpm	10.0 gpm
Filter Media Volume - Cubic Feet	0.75 ft ³	1.0 ft ³	1.5 ft ³	2.0 ft ³	3.0 ft ³
Filter Tank Size	8x44	9x48	10x54	12x52	14x65
Tank Jacket / Media Loaded	Yes	Yes	Yes	No	No
Shipping Weight	50 lbs	60 lbs	78 lbs	95 lbs	138 lbs

Specifications	WG185NNF75	WG185NNF10	WG185NNF15	WG185NNF20	WG185NNF30	WG185NNF10CALC	WG185NNF15CALC
	2174	2175	2176	2177	2226	2227	2228
Normal Service Flow Rate	2.0 gpm	3.0 gpm	5.0 gpm	6.0 gpm	7.0 gpm	3.0 gpm	5.0 gpm
Peak Service Flow Rate	3.5 gpm	5.0 gpm	8.0 gpm	10.0 gpm	12.0 gpm	5.0 gpm	8.0 gpm
Backwash Flow Rate	3.5 gpm	4.0 gpm	5.0 gpm	7.0 gpm	10.0 gpm	4.0 gpm	5.0 gpm
Filter Media Volume - Cubic Feet	0.75 ft ³	1.0 ft	1.5 ft	2.0 ft	3.0 ft	1.0 ft	1.5 ft
Filter Tank Size	8x44	9x48	10x54	12x52	14x65	9x48	10x54
Tank Jacket / Media Loaded	Yes	Yes	Yes	No	No	Yes	Yes
Shipping Weight	93 lbs	120 lbs	164 lbs	207 lbs	330 lbs	120 lbs	164 lbs

For low pH applications

Specifications	WG185MMF75	WG185MMF10	WG185MMF15	WG185MMF20	WG185MMF30
	2166	2167	2168	2169	2225
Normal Service Flow Rate	4.0 gpm	5.0 gpm	7.0 gpm	10.0 gpm	12.0 gpm
Peak Service Flow Rate	5.0 gpm	7.0 gpm	10.0 gpm	12.0 gpm	15.0 gpm
Micron Rating	15-20 micron	15-20 micron	15-20 micron	15-20 micron	15-20 micron
Backwash Flow Rate	4.0 gpm	5.0 gpm	7.0 gpm	10.0 gpm	14.0 gpm
Filter Media Volume - Cubic Feet	0.75 ft ³	1.0 ft ³	1.5 ft ³	2.0 ft ³	3.0 ft ³
Filter Tank Size	8x44	9x48	10x54	12x52	14x65
Tank Jacket / Media Loaded	Yes	Yes	Yes	No	No
Shipping Weight	79 lbs	118 lbs	144 lbs	198 lbs	342 lbs

Specifications	WG185UL-TRAMF75	WG185UL-TRAMF10	WG185UL-TRAMF15	WG185UL-TRAMF20
	2170	2171	2172	2173
Normal Service Flow Rate	4.0 gpm	5.0 gpm	8.0 gpm	10.0 gpm
Peak Service Flow Rate	7.0 gpm	8.0 gpm	10.0 gpm	12 gpm
Micron Rating	3-5 micron	3-5 micron	3-5 micron	3-5 micron
Backwash Flow Rate	5.0 gpm	7.0 gpm	10.0 gpm	14.0 gpm
Filter Media Volume - Cubic Feet	0.75 ft ³	1.0 ft ³	1.5 ft ³	2.0 ft ³
Filter Tank Size	8x44	9x48	10x54	12x52
Tank Jacket	Yes	Yes	Yes	No
Shipping Weight	90 lbs	135 lbs	205 lbs	255 lbs

- Continuous operation at flow rates greater than the service flow rate may affect capacity and efficiency performance.
- The manufacturer reserves the right to make product improvements which may deviate from the specifications and descriptions stated herein, without obligation to change previously manufactured products or to note the change.
- Peak flow rates are intended for intermittent use only and are for residential application only
- At the stated service flow rates, the pressure drop through these devices will not exceed 15 psig

Before Starting Installation

Tools, Pipe, and Fittings, Other Materials

- Pliers
- Screwdriver
- Teflon tape
- Razor knife
- Two adjustable wrenches
- Additional tools may be required if modification to home plumbing is required.
- Plastic inlet and outlet fittings are included with the filter. To maintain full valve flow, 3/4" or 1" pipes to and from the filter fittings are recommended. You should maintain the same, or larger, pipe size as the water supply pipe, up to the softener inlet and outlet.
- Use copper, brass, or PEX pipe and fittings.
- Some codes may also allow PVC plastic pipe.
- ALWAYS install the included bypass valve, or 3 shut-off valves. Bypass valves let you turn off water to the filter for repairs if needed, but still have water in the house pipes.
- 5/8" OD drain line is needed for the valve drain. A 10' length of hose is included with some models.

Taste & Odor Filter (Activated Carbon)

Unpleasant tastes and odors caused by chlorine or organic substances, such as decayed vegetation and run off, are absorbed by top quality activated carbon. The filter will automatically backwash to a predetermined schedule. This frees the bed of accumulated impurities and readies it for operation again.

Multimedia Filter

Suspended particulate matter, such as clay and silt, which gives water a cloudy appearance, is trapped in the filter bed to produce clean, clear water. A variety of gravels and sand facilitates more thorough backwashing and prevents channeling.

Nextsand (Ultramicro Filter)

This filter uses nextsand media for fine filtration of silt, sediment and turbidity. It provides higher solid loading, longer running times and superior performance. Please refer to special startup requirement of this media filter.

Neutralizing Filter

The Neutralizing contains special media which raises the pH of acidic water and neutralizes its acidic characteristics. On some applications, this filter also facilitates the removal of iron and manganese by raising the pH to enable an iron filter to be used. Occasional backwashing cleans the bed. Over a period of time, additional media may be required. The fill port options on the tanks make it easier for additional media refilling.

Where To Install The Filter

- Place the filter tank as close as possible to the pressure tank (well system) or water meter (city water).
- Place the filter tank as close as possible to a floor drain, or other acceptable drain point (laundry tub, sump, standpipe, etc.).
- Connect the filter to the main water supply pipe BEFORE the water heater. **DO NOT RUN HOT WATER THROUGH THE FILTER.** Temperature of water passing through the filter must be less than 100 deg. F.
- Do not install the filter in a place where it could freeze. **Damage caused by freezing is not covered by the warranty.**
- Put the filter in a place water damage is least likely to occur if a leak develops. The manufacturer will not repair or pay for water damage.
- A 120 volt electric outlet, to plug the included transformer into, is needed within 6 feet of the filter. The transformer has an attached 6 foot power cable. **Be sure the electric outlet and transformer are in an inside location, to protect from wet weather.**
- If installing in an outside location, you must take the steps necessary to assure the filter, installation plumbing, wiring, etc., are as well protected from the elements, contamination, vandalism, etc., as when installed indoors.
- **Keep the filter out of direct sunlight.** The sun's heat may soften and distort plastic parts.

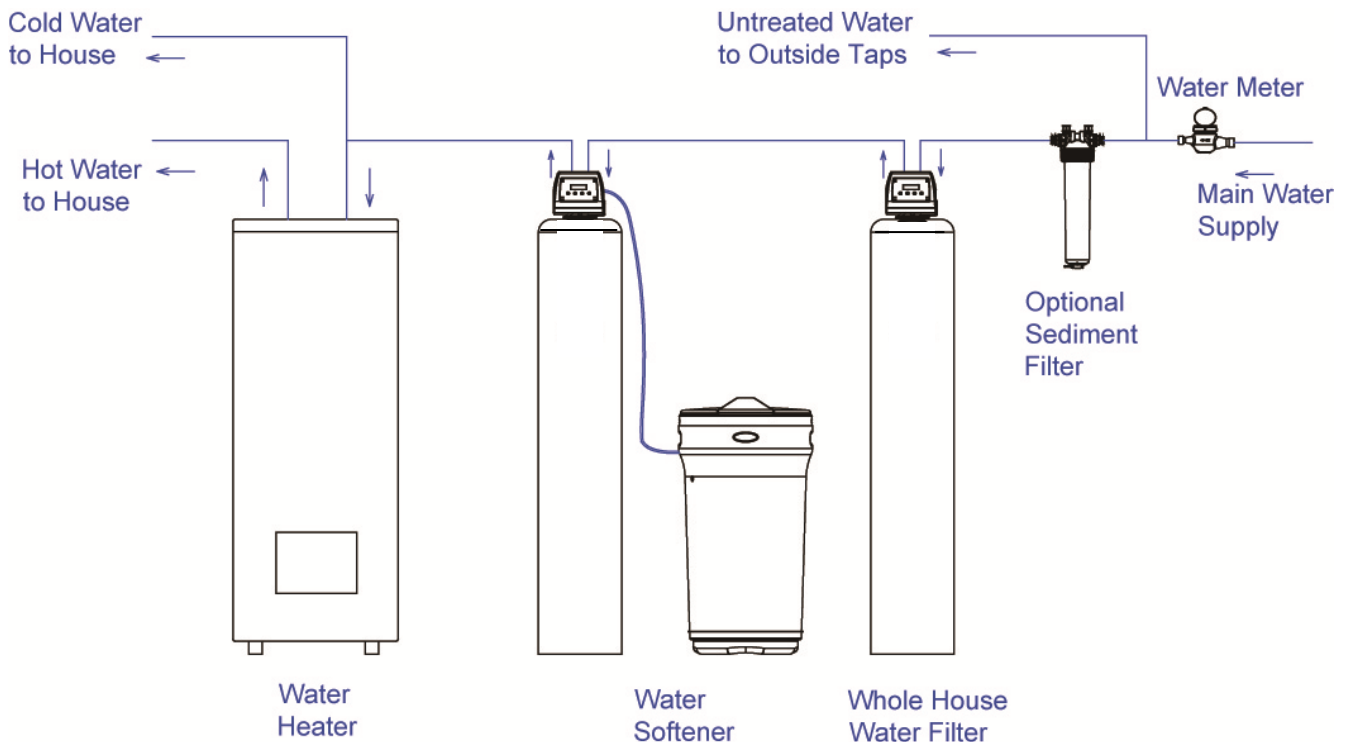

Sizing Requirements

Water Pressure

The water system must have a pump big enough to deliver the recommended backwash rate with a minimum pressure at the inlet of the filter of 30 psi. If the existing system cannot do this, it must be upgraded to do so. Whenever possible, the water system should be adjusted to deliver at least 30 psi for even more satisfactory results.

Backwash Flow Rates

The most important criteria in sizing a filter is the capacity of the pump. The water must pass through the filter media at the proper service flow rate. The filter must also be backwashed at a flow rate sufficient to dislodge and remove the captured particles. Failure to provide sufficient water will cause a build-up of particles in the filter media, impairing its ability. In order for your filter to backwash and rinse properly, your pump must be capable of providing the backwash flow rates indicated on page 4.

Check Your Pumping Rate

Two water system conditions must be checked carefully to avoid unsatisfactory operation or equipment damage:

1. Minimum water pressure required at the filter tank inlet is 20 psi.
2. Measuring the pumping rate of your pump:

With the pressure tank full, draw water into a container of known volume, and measure the number of gallons drawn until the pump starts again. This is draw-down. Divide this figure by cycle time and multiply the result by 60 to arrive at the pumping rate in gallons per minute (gpm). To aid in your calculation, insert the date in the following formula:

DRAW-DOWN _____ ÷ CYCLE TIME _____ x 60 = PUMPING RATE _____ (gals)
(secs.) (Gpm)

EXAMPLE: CYCLE TIME is 53 seconds. DRAW-DOWN is 6 gallons; then, PUMPING RATE equals:

$$6 \text{ gallons} \div 53 \text{ seconds} \times 60 = 6.8 \text{ gpm}$$

See chart on page 4 for minimum flow rates.

NOTE: If your pumping rate is inadequate for the model, do not install your filter until the problem has been corrected.

Installation Instructions

1. If your hot water tank is electric, turn off the power to it to avoid damage to the element in the tank.
2. If you have a private well, turn the power off to the pump and then shut off the main water shut off valve. If you have municipal water, simply shut off the main valve. Go to the faucet, (preferably on the lowest floor of the house) turn on the cold water until all pressure is relieved and the flow of water stops.
3. Locate the filter tank close to a drain where the system will be installed. The surface should be clean and level.
4. Connect the inlet and outlet of the filter using appropriate fittings. Perform all plumbing according to local plumbing codes.
 - Use a ½" minimum pipe or tubing size for the drain line
 - **ON COPPER PLUMBING SYSTEMS BE SURE TO INSTALL A GROUNDING WIRE BETWEEN THE INLET AND OUTLET PIPING TO MAINTAIN GROUNDING.**

Any solder joints near the valve must be done before connecting any piping to the valve. Always leave at least 6" (152 mm) between the valve and joints when soldering pipes that are connected to the valve. Failure to do this could cause damage to the valve.

5. Connect the drain hose (10 ft included) to the valve and secure it with a hose clamp (also included). Run the drain hose to the nearest laundry tub or drain pipe. This can be ran up overhead or down along the floor. If running the drain line more than 20 ft overhead, it is recommended to increase the hose size to 3/4". NEVER MAKE A DIRECT CONNECTION INTO A WASTE DRAIN. A PHYSICAL AIR GAP OF AT LEAST 1.5" SHOULD BE USED TO AVOID BACTERIA AND WASTEWATER TRAVELLING BACK THROUGH THE DRAIN LINE INTO THE FILTER.
6. Using the Allen Key (included), place the unit in the bypass position. Slowly turn on the main water supply. At the nearest cold treated water tap nearby remove the faucet screen, open the faucet and let water run a few minutes or until the system is free of any air or foreign material resulting from the plumbing work.
7. Make sure there are no leaks in the plumbing system before proceeding. Close the water tap when water runs clean.
8. Proceed to start up instructions.

Note: The unit is not ready for service until you complete the start-up instructions.

Filter Installation

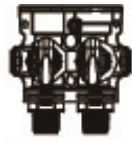

Service Position



Bypass Position

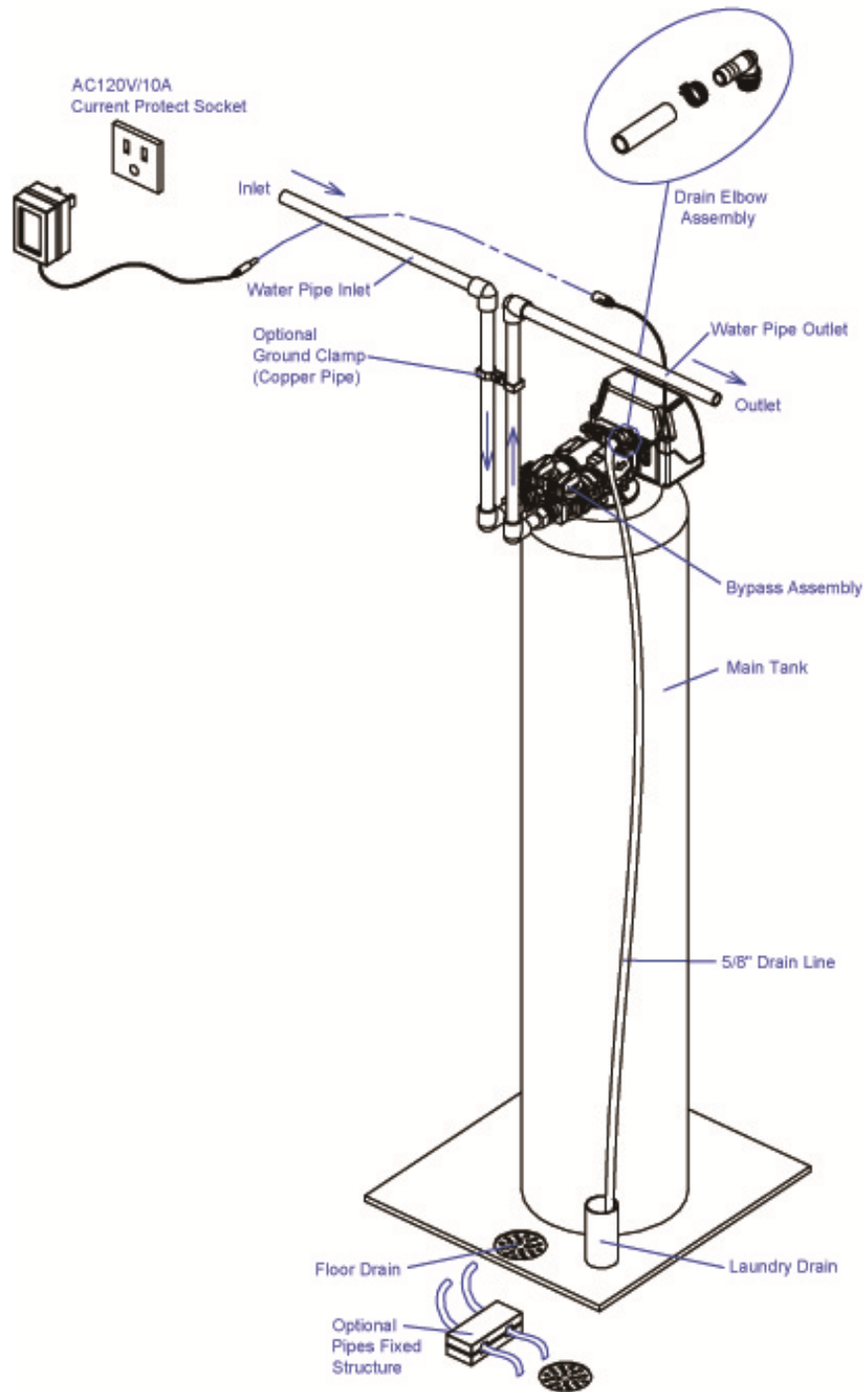

System Start-Up

Key Pad Configuration

- SETTINGS** This function is to enter the basic set up information required at the time of installation.
- MANUAL REGEN** This function is to initiate an immediate or delayed manual regeneration.
- DOWN / UP** Increase or decrease the value of the settings while in the programming mode.

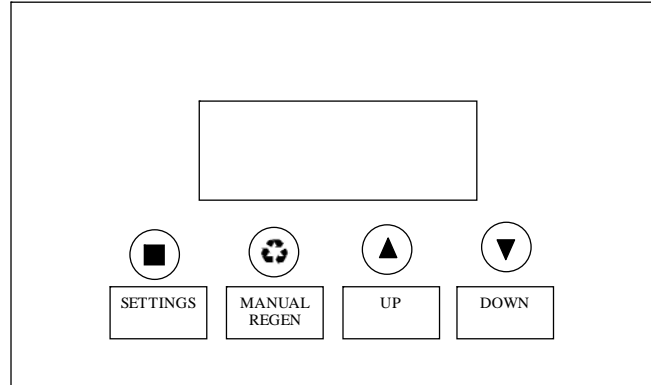

Manual Regeneration (Step / Cycle Valve)

DELAYED REGENERATION

Press and release the MANUAL REGEN. Button to set a delayed regeneration that will occur at the regeneration time. The main display page will show DELAYED REGEN ON. To cancel press and release the MANUAL REGEN. Button. The main display page will show DELAYED REGEN OFF.

IMMEDIATE REGENERATION

To start an immediate regeneration (or step valve through each position), press and hold the MANUAL REGEN. Button for 3 seconds (until beeps). The valve will start an immediate regeneration. Press any key to skip to the next cycle.

Start-up Instructions

1. Plug the valve into an approved power source.
2. When power is supplied to the control, the screen will display "INITIALIZING WAIT PLEASE" while it finds the service position.
3. Start an Immediate Manual Regeneration. The valve will immediately start moving to the BACKWASH position.
4. **Open the inlet on the bypass valve slightly and very slowly allow water to enter the unit. (If the water enters too quickly it will push the carbon up into the control valve and get plugged).**
5. **Once the unit has filled sufficiently that water is at least equal to the height of the top of the media shut down the water for 15 – 20 minutes for the carbon to soak. Unplug the power cable. After the carbon has soaked for the recommended time continue by plugging the power cable back in.**
6. Press any button to advance to the RINSE position. Check the drain line flow. Allow the water to run for 3-4 minutes or until the water is clear.
7. The valve will automatically advance to the SERVICE position after the RINSE cycle is complete. Open the outlet valve on the bypass, then open the nearest treated water faucet and allow the water to run until clear, close the tap and replace the faucet screen.
8. Program time, date, and number of days between regenerations into controller using Programming Instructions

Backwash Frequency

The table below can be used to help determine the frequency of regeneration for Multi-Media and Taste & Odour filters. Use this table as a guide since individual circumstances will require more or less frequent regenerations. This can be adjusted by the home owner to suite their individual needs with frequencies available from 1 – 99 days.

To prevent bacterial build up in the media, activated carbon filters should not exceed 6 days between backwashes.

To set a Neutralizing filter, follow the table under mild conditions

Sediment	Mild						Average						Extreme				
Taste Odor	Mild						Average						Extreme				
No. Of Persons	Days Between Back Wash (Regenerations)																
2	6	6	6	6	6	6	6	6	6	6	6	6	4	4	4	4	4
3	6	6	6	6	4	4	4	4	4	4	4	4	3	3	3	3	3
4	6	6	6	6	4	4	4	4	3	3	3	3	2	2	2	2	2
5	6	6	4	4	3	3	3	3	2	2	2	2	2	2	1	1	1
6	6	6	4	4	3	3	3	2	2	2	2	2	2	1	1	1	1
7	6	4	4	3	3	2	2	2	2	1	1	1	1	1	1	1	1
8	6	4	4	3	2	2	2	2	2	1	1	1	1	1	1	1	1
9	4	4	3	3	2	2	1	1	1	1	1	1	1	1	1	1	1
10	4	3	3	2	2	1	1	1	1	1	1	1	1	1	1	1	1

Programming Instructions

Settings

Press SETTINGS key (3 SECONDS / BEEP)

VALVE MODE
B.W. FILTER

TIME OF DAY
12:01 PM

YEAR
2012

MONTH
AUGUST

DAY
21

REGEN DAYS
3 DAYS

GALLONS
OFF

REGEN TIME
12:00 AM

PROGRAMMING
COMPLETE

TIME OF DAY, YEAR, MONTH, DAY,

Time of day is for normal operation of system and the scheduling of the regeneration time. The date is used in a diagnostic function to track the last time the system regenerated.

REGEN DAYS

This value is the number of days between regenerations or back washes to clean the filters.

GALLONS

Default value is OFF. Adjust the GALLONS to set the capacity. This will cause the unit to regenerate either when the gallons remaining goes to zero or the days between regeneration is zero. Which ever occurs first.

REGEN TIME

This setting determines the time of day to perform a scheduled regeneration. The normal regen time for a filter is 12:00 AM.

About The System

Control Operation During A Power Failure

In the event of a power failure, the valve will keep track of the time and day for 48 hours. The programmed settings are stored in a non-volatile memory and will not be lost during a power failure. If power fails while the unit is in regeneration, the valve will finish regeneration from the point it is at once power is restored. If the valve misses a scheduled regeneration due to a power failure, it will queue a regeneration at the next regeneration time once power is restored.

Main Display

The main display page will pause on the Date and Time page for 5 seconds. Then it will continually scroll through all of the system diagnostic display pages. Depending on the Valve Type some pages will not be displayed. To manually scroll through the diagnostics, press the down or up key. To reset the TOTAL REGENS, TOTAL GALLONS OVER RUN TOTAL, or PEAK flow rates, press and hold the MENU until the value changes to zero.

PARAMETER	DESCRIPTION
JULY/17/2012 8:30 PM	Month, Day, Year, Time
TOTAL 1,500 GAL REMAIN 1,200 GAL	The total amount is the system capacity when fully regenerated. The remaining is the capacity left in the system.
LAST REGEN 9/24/12	The date of the last regeneration.
TOTAL REGENS 10	The total number of regenerations.
TOTAL GALLONS 001590 GAL	The total amount of gallons treated by the system.
TOTAL 4 DAYS REMAIN 3 DAYS	The number of days remaining before regeneration. This option is only in filter mode.
OVER RUN TOTAL 0000 GAL	The total amount of water that has exceeded the system capacity over the last 4 regenerations. When remaining goes to zero, the gallons used will be added to over run total.
CURRENT 1.5 GPM PEAK 6.5 GPM	The current flow rate and the peak flow rate since the last regeneration.
DELAYED REGEN OFF	Advises whether a delayed regeneration has been scheduled manually or automatically.
REGEN TIME 12:00 AM	The current setting for regeneration time.
VALVE MODE B.W. FILTER	The current setting of the valve mode.

Regeneration Process

Periodically the filter will require a back wash to clean the trapped particles and unpack the filter bed to restore the system flow rates. The table below explains the regeneration steps.

Step	Name	Description
#1	Back Wash	Fresh water is introduced to the bottom of the tank flowing upwards expanding the filter media to rinse out any dirt or small particles to the drain and to uncompact the bed to restore full service flow rates.
#2	Rinse	Fresh water is introduced from the top of the tank flowing down through the filter bed rinsing any unfiltered water to the drain.

New Sounds

You may notice new sounds as your filter operates. The regeneration cycle lasts up to 30 minutes. During this time, you may hear water running intermittently to the drain.

Automatic Raw Water Bypass During Regeneration

The regeneration cycle can last 30 minutes after which filtered water service will be restored. During regeneration, un-filtered water is automatically bypassed for use in the household. Hot water should be used as little as possible during this time to prevent un-filtered water from filling the water heater. This is why automatic regeneration is set for sometime during the night and manual regenerations should be performed when little or no water will be used in the household.

Normal regeneration time is 12:00 AM.

Manual Bypass

In the case of emergency you can isolate your water filter from the water supply using the bypass valve located at the back of the control. In normal operation the bypass is open with the on/off knobs in line with the inlet and outlet pipes.

To isolate the filter, simply rotate the knobs clockwise (as indicated by the word BYPASS and arrow) until they lock. You can use your water related fixtures and appliances as the water supply is bypassing the filter. However, the water you use will be hard. To resume water service, open bypass valve by rotating the knobs counterclockwise.

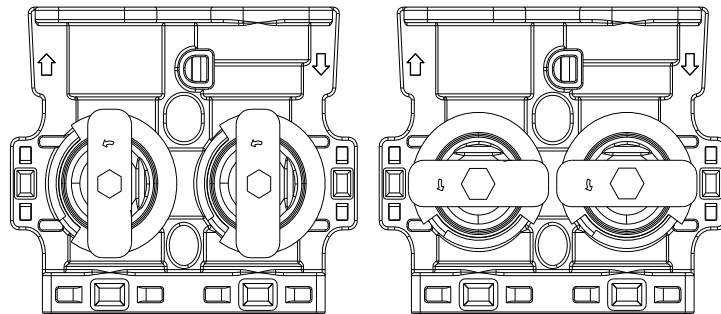

SERVICE POSITION

BYPASS POSITION

System Configuration

Suggested Filter Valve Configuration	
Tank Size (Diameter)	Drain Line Flow Control (DLFC)
8"	#5 (3.5 GPM)
9"	#A (5.0 GPM)
10"	#A (5.0 GPM)
12"	#B (7.0 GPM)
14"	#C (10.0 GPM)
16"	none

Maintenance

Maintenance of your new water filter requires very little time or effort but it is essential. Regular maintenance will ensure many years of efficient and trouble-free operation.

1. Periodically make sure your pump is performing satisfactorily to ensure sufficient water is available for backwashing the filter.
2. Periodically test your raw and filtered water to ensure conditions are still the same for your original settings and that the unit is working the way it is intended to. Water testing is often the best way to determine when the filter media will require replacement.
3. Periodically check that the drain line is clear and free from any obstructions.

Care of Your System

To retain the attractive appearance of your new water filter, clean occasionally with mild soap solution. Do not use abrasive cleaners, ammonia or solvents. Never subject your softener to freezing or to temperatures above 100°F.

Replacing the Media Bed

NFF- Neutralizing Filter - the media bed in a neutralizing filter is slowly dissolved and has to be replaced. The frequency of replacement varies, depending on water quality - consult your dealer to determine the expected life of your media bed.

AC and CLAF- Taste and Odor Filter - under normal operating conditions the effective life of the filter media is approximately one to three years, depending on the water quality, after which, taste and odor problems may return. When this happens, contact your dealer for a replacement media bed.

MM - Sediment and Turbidity Filter - under normal operating conditions, the media should never need to be replaced. However, if you experience pressure loss and cannot correct it with a manual regeneration, your media bed may need replacing - contact your dealer.

Installation & Replacement Filter Media Pak

Check to ensure all media parts are received.

The first step in replacing the media bed is to shut off the water supply to the filter. Then place the unit into the backwash position to release any pressure in the lines. At this point, you must disconnect the plumbing from the inlet and outlet. Then unscrew the control valve from the fiberglass tank. Once this has been done, remove the distributor tube. Then you can remove the filter media and two types of gravel from the tank. The quickest way to do this is by simply tipping the tank upside down into a large drum or pail. The tank must be rinsed out completely and have no media or gravel left in it at all.

Loading the Media Pak

Place the distributor tube back down the center of the tank. NOTE: the top of this tube should be plugged with a rag or cork to prevent media from entering. Pour the bag of coarse gravel into the tank, and then pour the bag of fine gravel into the tank.

It is important that the distributor tube is not moved or pulled out as it is not possible to put it down to the bottom of the tank once gravel or media are in the tank.

Finally pour the larger bag(s) of media into the tank in the following order:

Multimedia Filters

- | | |
|------------------------------|---------------------------------|
| 1. Coarse gravel (1/2 x 1/4) | 4. Fine garnet (30 x 40) |
| 2. Fine gravel (1/8 x 1/16) | 5. Fine filter sand (.45 x .55) |
| 3. Coarse gravel (8 x 12) | 6. Anthrafil |

ACF Carbon Filters

1. Coarse gravel
2. Fine gravel
3. Carbon

Neutralizing Filters

- | | |
|------------------|--------------|
| 1. Coarse gravel | 4. Mag Oxide |
| 2. Fine gravel | |
| 3. Calcite | |

UltramicroFilters

1. Coarse gravel (1/2 x 1/4)
2. Fine gravel (1/8 x 1/16)
3. Nextsand media

Once this is done, the rag or cork should be removed from the distributor tube. Clean off the top of the tank. Finally place the control valve on the tank and on to the distributor tube. Tighten the control valve on to the tank. Connect or reconnect the inlet and outlet and drain. The control valve should be in the backwash position. Slowly open the inlet valve water supply and slowly fill the filter tank until water appears at the open drain line. Return the

Replacing Drain Line Flow Control (DLFC)

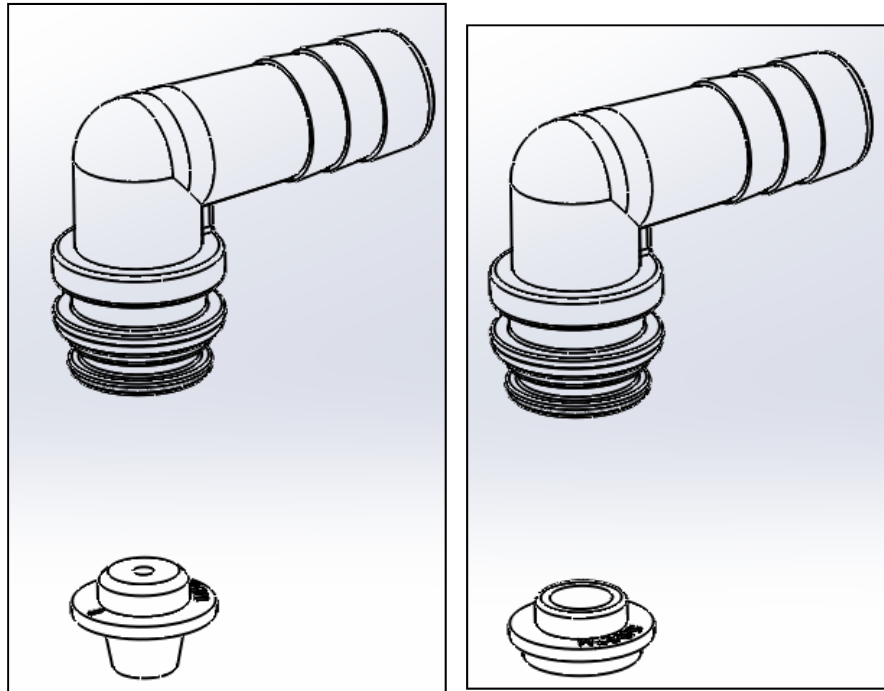

1. Remove the red clip that secures the drain line elbow.
2. Remove the BLFC washer from the elbow fitting.
3. Reassemble using the reverse procedure.

Main Repair Parts - Connectors

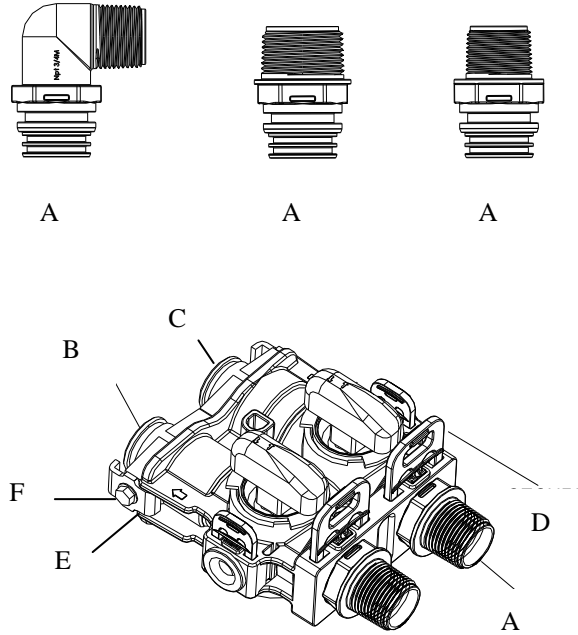

REPLACEMENT PARTS - CONNECTORS			
Replacement Part Number	Part Description	DWG #	Quantity
60010020	3/4" NPT ELBOW	A	2
60010019	1" NPT STRAIGHT	A	2
60010023	3/4" NPT STRAIGHT	A	2
60010079	VALVE COUPLING INLET	B	1
60010101	VALVE COUPLING OUTLET (METER SIDE)	C	1
60010025	PLASTIC SECURE CLIP	D	2
60010046	BYPASS SS CLIP	E	2
60010047	BYPASS SS SCREW	F	2

Control Valve Exploded View

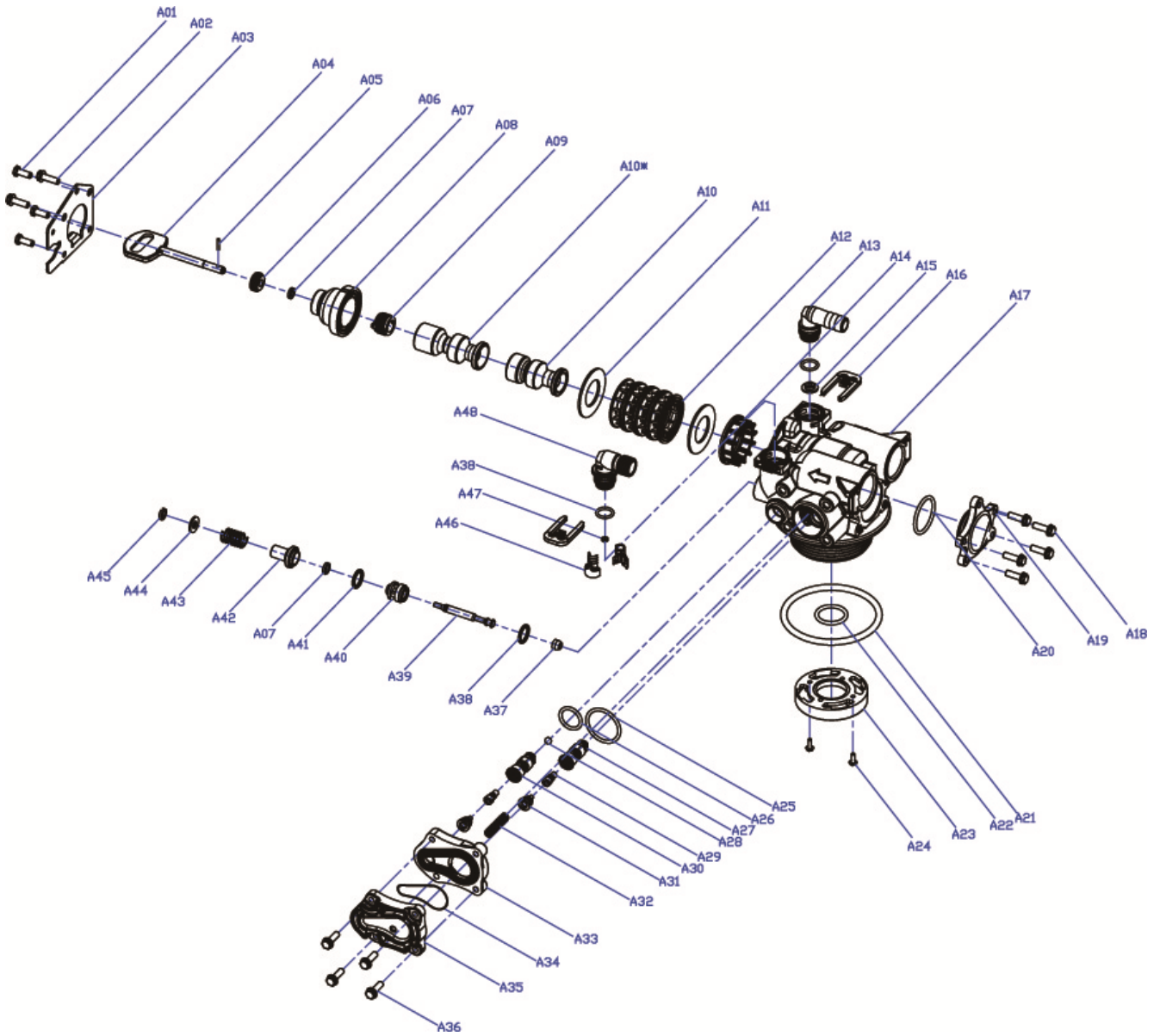

VALVE REPAIR PARTS LIST			
Replacement Part Number	Part Description	Replacement Part Number	Part Description
60010127	INJECTOR SET #0000 BLACK	60010129	85HE UPFLOW PISTON ASSEMBLY
60010126	INJECTOR SET #000 GREY	60010171	85HE DOWNFLOW PISTON ASSEMBLY
60010035	INJECTOR SET #00 VIOLET	60010130	85HE SEAL & SPACER KIT
60010034	INJECTOR SET #0 RED	60010131	85HE DLFC #1 1.5 GPM
60010033	INJECTOR SET #1 WHITE	60010132	85HE DLFC #2 2.0 GPM
60010032	INJECTOR SET #2 BLUE	60010133	85HE DLFC #3 2.4 GPM
60010031	INJECTOR SET #3 YELLOW	60010135	85HE DLFC #5 3.5 GPM
60010128	BLFC 0.2 GPM	60010136	85HE DLFC #A 5.0 GPM
60010110	BLFC 0.3 GPM	60010137	85HE DLFC #B 7.0 GPM
60010082	BLFC 0.7 GPM	60010138	85HE DLFC #C 10.0 GPM

Control Valve Parts List

185HE CONTROL VALVE (DOWNFLOW)				
Replacement Part Number	MFG Part Number	Part Description	DWG #	Quantity
	5056087	Screw-M5x12(Hexagon)	A01	3
	5056088	Screw-M5x16(Hexagon With Washer)	A02	2
	5056047	End Plug Retainer	A03	1
	5031016	BNT85HE Piston Rod	A04	1
	5056097	Piston Pin	A05	1
	5031015	BNT85HE Quad Ring Plug Cover	A06	1
	5056070	Quad Ring	A07	2
	5031011	BNT85HE End Plug	A08	1
	5031014	BNT85HE Piston Retainer	A09	1
	5057001	BNT85HE Piston(Electrical Downflow)	A10	1
	5056073	Seal	A11	5
	5056021	Spacer	A12	4
	5010082	Drain Fitting-B	A13	1
	5031005	BNT85HE Spacer	A14	1
	5056186	DLFC-2#	A15	1
	5056172	Secure Clip-s	A16	2
	5031002	BNT85HE Valve Body	A17	1
	5056508	Screw-M5x12(Hexagon With Washer)	A18	5
	5030004	BNT85 End Cover	A19	1
	5030013	O-Ring- ϕ 30x2.65	A20	1
	5056063	O-Ring- ϕ 78.74x5.33	A21	1
	26010103	O-Ring- ϕ 25x3.55	A22	1
	7060007	Valve Bottom Connector	A23	1
	13000426	Screw-ST2.9X13(Large Washer)	A24	2
	5031022	O-Ring- ϕ 32x3	A25	1
	5031021	O-Ring- ϕ 18x3	A26	1
	5031013	Injector Plug Body	A27	1
	30110007	Plastic Ball ϕ 6	A28	1
	30040089	Injector Throat	A29	2
	5031012	BNT85HE Injector Fixed Sleeve	A30	1
	30040090	Injector Nozzle	A31	2
	5056103	Injector Screen	A32	1
	5031003	BNT85HE Injector Cover Body	A33	1
	5031018	O-Ring- ϕ 40x2.65	A34	1
	5031004	BNT85HE Injector Cover Cap	A35	1
	5031027	Screw-M5x25(Hexagon With Washer)	A36	4
	5056075	Seal Mat	A37	1
	5056134	O-Ring- ϕ 12x2	A38	3
	5056054	Injector Stem	A39	1
	5056031	Injector Spacer	A40	1
	5056081	O-Ring- ϕ 12.5x1.8	A41	1
	5056030	Injector Cap	A42	1
	5056093	Injector Screen	A43	1
	5010049	Special Washer	A44	1
	5056105	Retaining Ring	A45	1
	5031010	BNT85HE BLFC Fixed Sleeve	A46	2
	5056076	BLFC-2#	A47	1
	5005629	Injector Fitting(3/8".Elbow)	A48	1

Power Head Exploded View

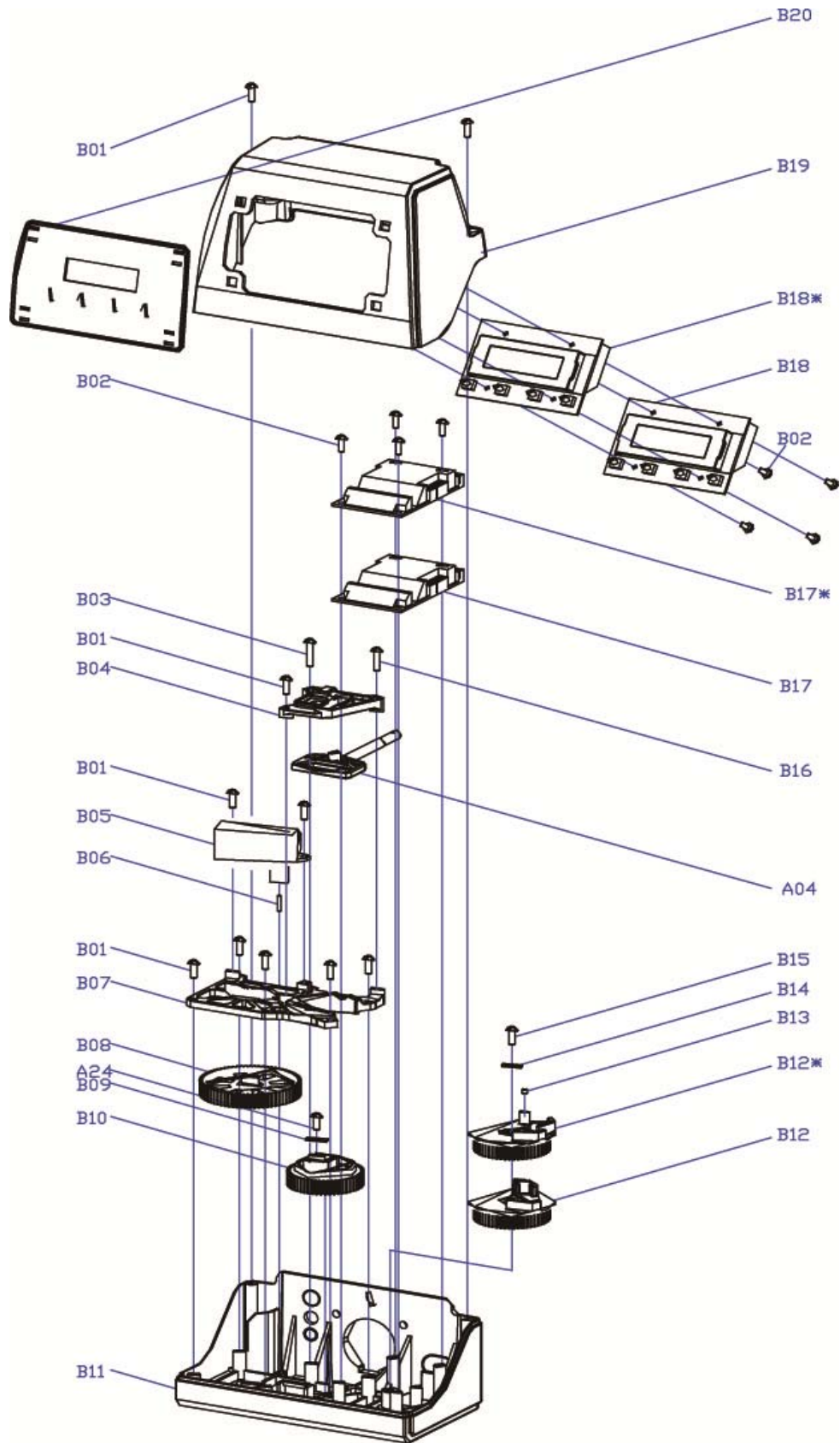

Power Head Parts List

185HE POWER HEAD (DOWNFLOW)				
Replacement Part Number	MFG Part Number	Part Description	DWG #	Quantity
	5056084	Screw-ST3.5X13	B01	10
	5010037	Screw-ST2.9X10	B02	9
	13000416	Screw-ST3.5X25	B03	1
	5031007	BNT85HE Piston Rod Guide Plate	B04	1
	5056510	Motor-12v/2rpm	B05	1
	5030014	Motor Power Cable		1
	11700005	Wire Connector		2
	5056098	Motor Pin	B06	1
	5031006	BNT85HE Mounting Plate	B07	1
	5030009	BNT85 Drive Gear	B08	1
	13000426	Screw-ST2.9X13(Large Washer)	A24	2
	5056139	Washer-3x13	B09	1
	5030007	BNT85 Main Gear	B10	1
	5030005	BNT185 Housing	B11	1
	5031017	BNT85HE Brine Gear(Downflow)	B12	1
	5010023	Magnet(3x2.7)	B13	1
	5056141	Washer-4x12	B14	1
	5056166	Screw-ST4.2X12(Large Washer)	B15	1
	5031016	BNT85HE Piston Rod	A04	1
	5010036	Screw-ST3.5X16	B16	1
	5031026	BNT85HE Main Pcb(Downflow)	B17	1
	5010031	Meter Assembly		1
	5010046	Meter Strain Relief		1
	5010029	Power Cable		1
	5010035	Power Strain Relief		1
	19010105	Wire Rope-3x100		2
	5031024	BNT85HE Display(Downflow)	B18	1
	5030021	BNT85 Wiring Harness		1
	5030003	BNT85 Cover	B19	1

Trouble Shooting

Issue	Possible Cause	Possible Solution
A. Unit fails to initiate a regeneration cycle.	1. No power supply.	Check electrical service, fuse, etc.
	2. Defective circuit board.	Replace faulty parts.
	3. Power failure.	Reset time of day.
B. FILTER BLEEDS TASTE AND ODOR OR SEDIMENT	1. By-pass valve open.	Close by-pass valve.
	2. Electrical service to unit has been interrupted	Assure permanent electrical service (check fuse, plug or switch)
	3. Defective or stripped media bed	Replace media
	4. Quality of water has worsened	Have water sample analyzed to determine any change
	5. Filter capacity too small	Replace with larger unit or add another filter
	6. Filter not backwashing enough	Be sure control is not clogged or drain line restricted. Be sure water pressure has not dropped and that pump has sufficient capacity.
	7. Leak between valve and central tube.	Check if central tube is cracked or o-ring is damaged. Replace faulty parts.
	8. Internal valve leak.	Replace valve seals, spacer, and piston assembly.
C. Low water pressure.	1. Iron or scale build up in line feeding unit.	Clean pipes.
	2. Iron build up inside valve or tank.	Clean control and add resin cleaner to clean bed. Increase regeneration frequency.
	3. Inlet of control plugged due to foreign material.	Remove piston and clean control valve.
D. Filter media in drain line.	1. Air in water system.	Check well system for proper air eliminator control.
	2. Incorrect drain line flow control (DLFC) button.	Check for proper flow rate.
E. Valve continuously cycles.	1. Defective position sensor PCB.	Replace faulty parts.
F. Flow to drain continuously.	1. Valve settings incorrect.	Check valve settings.
	2. Foreign material in control valve.	Clean control.
	3. Internal leak.	Replace seals, spacers, and piston assembly.

Warranty

WaterGroup warrants that your new water filter is built of quality material and workmanship. When properly installed and maintained, it will give years of trouble free service.

Seven Year Complete Parts Guarantee

WaterGroup will replace any part which fails within 84 months from date of manufacture, as indicated by the serial number, provided the failure is due to a defect in material or workmanship. The only exception shall be when proof of purchase or installation is provided and then the warranty period shall be from the date thereof.

Life Time Warranty on Mineral Tanks

WaterGroup will provide a replacement mineral tank to any original equipment purchaser in possession of a tank that fails provided that the water filter is at all times operated in accordance with specifications and not subject to freezing.

General Provisions

WaterGroup assumes no responsibility for consequential damage, labour or expense incurred as a result of a defect or for failure to meet the terms of these guarantees because of circumstances beyond its control.