



# **T Series**

*Reverse Osmosis Water Treatment Systems*

**Operating and Maintenance Manual**

# Table of Contents

Introduction .....	1
Features.....	2
Basic Principles.....	3
Unit Configurations .....	6
T Series Specifications .....	7
RO Installation .....	8
Accessories.....	19
Operation .....	21
Initial Startup .....	23
Flow Diagram.....	26
Wiring Diagram .....	27
Service and Maintenance .....	28
RO Parts Diagrams and Lists .....	39

# Introduction

Before you operate the T Series reverse osmosis systems, read this manual to become familiar with the device and its capabilities.

T Series reverse osmosis systems are designed to meet the needs of applications for high quality water. This manual contains important information about the unit, including information needed for installation, operating, and maintenance procedures. A troubleshooting section provides a guide for quick and accurate problem solving.

In order for the water treatment system to continue to provide high quality water, you must develop a thorough understanding of the system and its operation. Review this manual before making any attempt to install, operate, or service the system. Installation or maintenance done on this system by an untrained service person can cause major damage to equipment or property damage.

## About this Manual

This manual:

- Familiarizes the operator with the equipment
- Explains installation and setup procedures
- Provides basic programming information
- Explains the various modes of operation
- Gives specifications and troubleshooting information

This publication is based on information available when approved for printing. Continuing design refinements could cause changes that may not be included in this publication.

## Safe Practices

Throughout this manual there are paragraphs set off by special headings.

### Notice

Notice is used to emphasize installation, operation or maintenance information which is important, but does not present any hazard. For example,

<b>NOTICE</b> <b>The nipple must extend no more than 1 inch above the cover plate.</b>
--

### Caution

Caution is used when failure to follow directions could result in damage to equipment or property. For example,

	<b>CAUTION!</b> <b>Disassembly while under water pressure can result in flooding.</b>
---	---

### Warning

Warning is used to indicate a hazard which could cause injury or death if ignored. For example,

	<b>WARNING!</b> <b>Electrical shock hazard! Unplug the unit before removing the timer mechanism or cover plates!</b>
---	--

The CAUTION and WARNING paragraphs are not meant to cover all possible conditions and situations that may occur. It must be understood that common sense, caution, and careful attention are conditions which cannot be built into the equipment. These MUST be supplied by the personnel installing, operating, or maintaining the system.

Be sure to check and follow the applicable plumbing codes and ordinances when installing this equipment. Local codes may prohibit the discharge of acid or caustic solutions to drain. An extra solution tank should be used to neutralize the solution before discharging to drain.

Use protective clothing and proper face or eye protection equipment when handling chemicals or power tools.

The T Series Reverse Osmosis Systems are the direct result of WaterGroup's long time experience in membrane applications around the world. From process water for any size business to treating water for an entire city, WaterGroup has the knowledge and the range of products you need to get the job done.

The T Series reverse osmosis system is sized to serve small-to-medium-sized applications that require high-quality reverse osmosis water. It is designed with the flexibility to closely match your treatment requirements from 0.2 to 2.0 gallons per minute (288 to 2,880 gallons per day). Mount the system on a wall to save floor space, or install it on the floor using an option floor stand. A rich standard feature set with multiple options can satisfy virtually any application. Select the right size and choose any options needed to complete your system.

## Key Product Features

- Simple System Integration
- Flexible Configurations
- Quick Delivery/Easy Installation
- Product and Waste Flow Meters
- Electronic Control Features
  - Pretreatment Lockout
  - Storage Tank Level Control
  - Low Pressure Auto-Restart
  - Startup Flush
  - Auto Flush (Time Flush)

## Flush Options

- Start up flush: Inlet valve opens for a specified number of minutes whenever system starts to make RO water. Flushes reject side of membrane and reduces the time it takes the RO to rinse up to quality.
- Time flush: In the running mode, the inlet solenoid valve remains open, allowing the reject side of the RO to be flushed based on preset number of running hours for a set number of minutes. (May extend membrane cleaning frequency in some applications).

## IMPORTANT NOTE:

Connect only to a circuit that is protected by a ground-fault circuit-interrupter (GFCI).

**GROUNDING INSTRUCTIONS** – This appliance must be grounded. In the event of a malfunction or breakdown, grounding will reduce the risk of electric shock by providing a path of least resistance for electric current. This appliance is equipped with a cord having an appliance-grounding conductor and a grounding plug. The plug must be plugged into an appropriate outlet that is installed and grounded in accordance with all local codes and ordinances.

**WARNING** – Improper connection of the appliance-grounding conductor can result in a risk of electric shock. Check with a qualified electrician or service representative if you are in doubt whether the appliance is properly grounded. Do not modify the plug provided with the appliance; if it will not fit the outlet, have a proper outlet installed by a qualified technician.

# Basic Principles

## Reverse Osmosis

In order to understand reverse osmosis, we must first define osmosis. Osmosis is the passage of a liquid through a semi-permeable membrane. A semi-permeable membrane is a membrane which allows one component of a solution to pass through it and not the others. In osmosis, there is a tendency for a liquid to go from an area of less concentration to an area of more concentration through a semi-permeable membrane. Figure 1 shows the osmotic process.

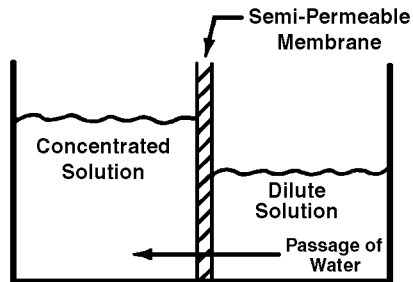

Figure 1. Osmotic process.

If pressure is applied to the concentrated solution, reverse osmosis will take place. The pressure causes a flow through the semi-permeable membrane into the dilute solution. The semi-permeable membrane acts as a barrier to ions and does not allow them to pass through into the dilute solution. When applied to water, this means that the product water has a reduced total dissolved solids content as a result of the passage of water molecules through the membrane while the mineral ions are rejected. See Figure 2.

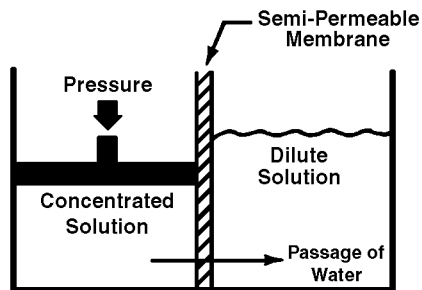

Figure 2. Effect of pressure on reverse osmosis.

**NOTE** Numbers used in these examples might not reflect those of your unit.

# Rejection and Recovery

Feed water entering the system is split into two streams, a product stream and a concentrate stream. See Figure 3.

During the process of reverse osmosis, some of the water has its dissolved solids content reduced by approximately 99%. This high quality product water is sent to service.

The rest of the feed water contains the dissolved solids removed from the product water, in addition to the dissolved solids already present in the feed water. This concentrate water is sent to drain.

The amount of total dissolved solids rejected by the system is expressed as a percentage. A 90% rejection means that 90% of the dissolved solids have been removed from the feed water by the system. To calculate the percent rejection, use the following equation:

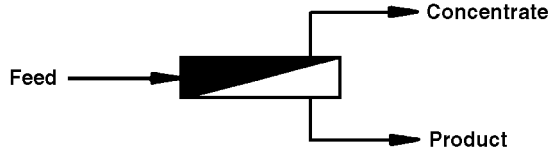

Figure 3. Feed water product stream and concentrate stream.

During the process of reverse osmosis, some of the water has its dissolved solids content reduced by approximately 96%. This high quality product water is sent to service.

The rest of the feed water contains the dissolved solids removed from the product water, in addition to the dissolved solids already present in the feed water. This concentrate water is sent to drain.

The amount of total dissolved solids rejected by the system is expressed as a percentage. A 90% rejection means that 90% of the dissolved solids have been removed from the feed water by the system. To calculate the percent rejection, use the following equation:

$$\frac{(\text{Feed TDS} - \text{Product TDS})}{(\text{Feed TDS})} \times 100 = \% \text{ Rejection}$$

Where Feed TDS is the total dissolved solids content of the water going into the system, and Product TDS is the total dissolved solids content of the high quality product water. The GROC controller displays the Product TDS (TDS OUT) on the information screen. The feed TDS needs to be measured with a handheld meter.

For example, if the Feed TDS is 600 ppm and the Product TDS is 24 ppm,

$$\frac{600-24}{600} \times 100 = 96\% \text{ Rejection}$$

The amount of high quality water recovered for use as a percentage of the water fed into the reverse osmosis system is called percent recovery. The GROC controller displays the Feed Flow (FFLOW) and Product Flow (PFLOW) on the Information screen. The Recovery is also displayed on an Information screen. Use the following equation to calculate percent recovery:

$$\frac{\text{Product Water Flow Rate (PFLOW)}}{\text{Feed Water Flow Rate (FFLOW)}} \times 100 = \% \text{ Recovery}$$

	<p><b>CAUTION!</b> An understanding of rejection/recovery percentages and temperature compensation is essential for monitoring and evaluating the performance or condition of the reverse osmosis system. <b>DO NOT</b> operate the system before becoming familiar with these concepts.</p>
---	--

## Temperature Compensation

As the feed water temperature decreases so will the product water production. The rated product flow (gallons per minute, gpm) as shown for the various models on page 7 is based upon the feed water temperature equal to 77° F.

## Feed Water Limits

Before starting the installation, verify that the feed water meets the limits shown in Table 1, and that a water softener is used for pre-treatment.

Property	Minimum	Maximum
Turbidity (NTU)	0.0	1.0
pH*	6	11
Chlorine (ppm)	0.0	0.1
Total Dissolved Solids (ppm)	50	2500
Temperature (°F)	33	100
Silt Density Index	0.0	5.0
Iron (ppm)	0.0	0.1

Table 1. Feed water limits.

\*Short term cleaning is acceptable for pH ranges between 2.0/12.0. Additional treatment is required when chloramines are present and the pH levels exceed 9.0.

**NOTICE** In some applications, a water softener is not required. Consult a dealer for further information on these special applications.

# Unit Configurations

A T-2200 unit is pictured in Figure 4. Width of membrane rack varies with model. See "RO Parts Diagrams and Lists" on page 39 for a list of component part numbers.

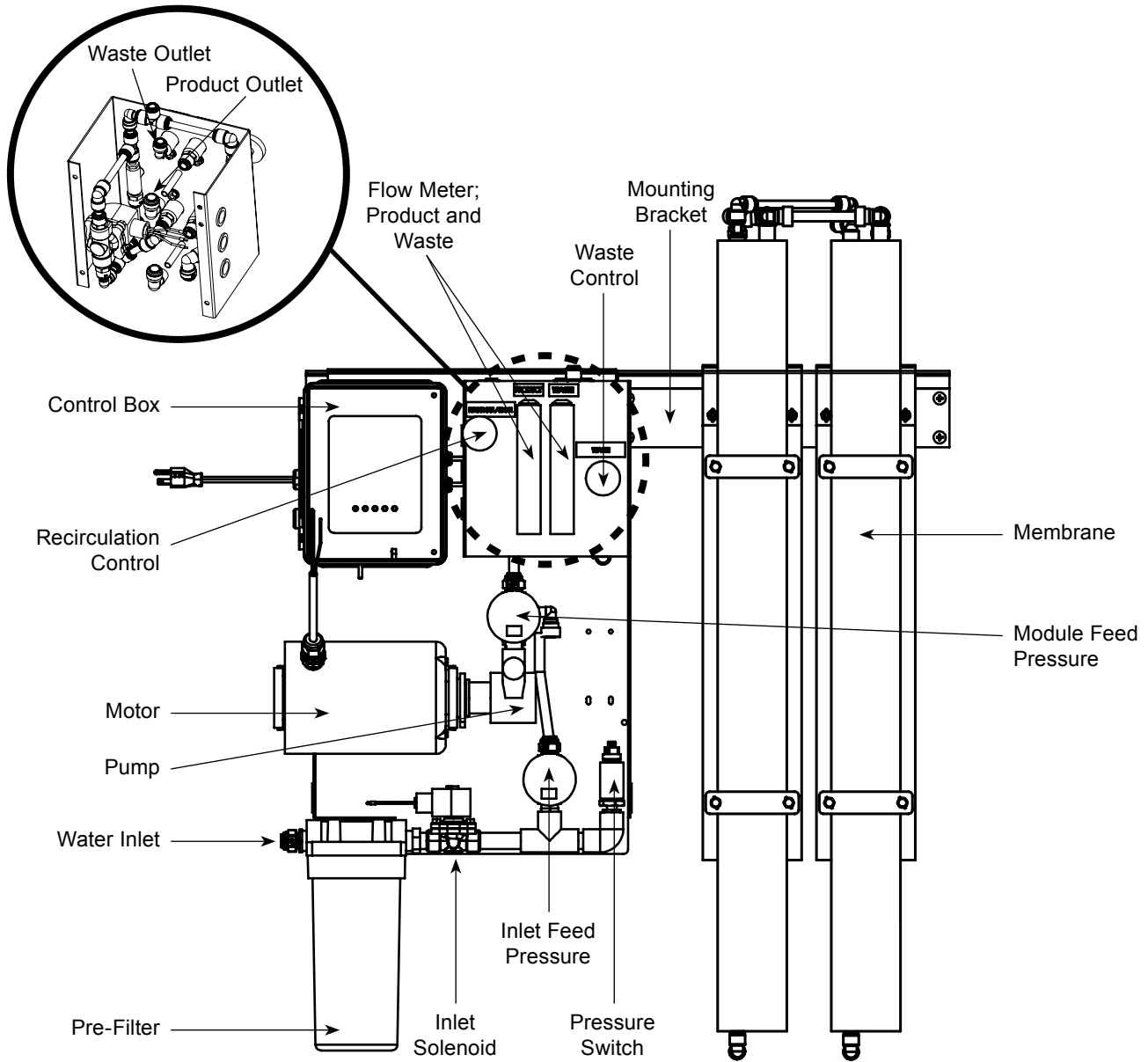

Figure 4. T-2200 front view.



# T Series Specifications

	T-250	T-500	T-750	T-1000	T-1200	T-1700	T-2200	T-2000F	T-4000F
Nominal Capacity, GPD [m <sup>3</sup> /hr]*	250 [0.04]	500 [0.08]	750 [0.12]	1000 [0.16]	1200 [0.19]	1700 [0.27]	2200 [0.35]	2000 [0.32]	4000 [0.63]
Dimensional, Series T Units									
Width - in [mm]	37 [940]								
Depth - in [mm]	10 [254]								
Height - in [mm]	37.75 [959]				46.25 [1175]				
Operating Weight, lb [kg]	77 [35]	81 [37]	92 [42]	96 [44]	88 [40]	103 [47]	111 [50]	97 [44]	129 [59]
Unit Connections									
Inlet (NPT)	0.5								
Product (Tube)	0.5								
Concentrate (Tube)	0.38								
Electrical									
Motor Horsepower, hp [kW]	0.333 [0.25]				0.75 [0.56]				
Power Requirement (VAC/Hz/ phase)	115/1/60								
Full Load Current, amp (@115V)	8				12				
Hydraulic - Prefilter									
Housing Quantity	1								
Cartridge Quantity, Rating, micron	1, 5								
Cartridge Length - in [mm]	10 [254]								
Hydraulic - RO									
RO Housing Quantity	1	2	3	4	2	3	4	1	2
RO Element Quantity	1	2	3	4	2	3	4	1	2
RO Element Size - in [mm]	2.5x21 [63.5x533.4]				2.5x40 [63.5x1016]			4x40 [101.6x1016]	
RO Array	1	1:1	1:1:1	1:1:1:1	1:1	1:1:1	1:1:1:1	1	1:1
Product Flow - gpm [L/min]*	0.17 [0.64]	0.35 [1.32]	0.52 [1.97]	0.69 [2.61]	0.83 [3.14]	1.18 [4.47]	1.53 [5.79]	1.40 [5.30]	2.8 [10.6]
Concentrate Flow - gpm [L/min]*	0.51 [1.93]	0.35 [1.32]	0.52 [1.97]	0.69 [2.61]	0.83 [3.14]	1.18 [4.47]	1.53 [5.79]	4.17 [15.78]	2.78 [10.52]
Required Inlet Feed Flow - gpm [L/ min]	0.68 [2.57]	0.7 [2.65]	1.04 [3.94]	1.38 [5.22]	1.66 [6.28]	2.36 [8.93]	3.06 [11.58]	5.56 [21.04]	5.56 [21.04]
Pump Flow @ 150 psi, gpm [L/min]	1.6 [6.06]				2.7 [10.44]		3.1 [11.73]	5.6 [21.2]	
Maximum Module Feed Pressure psig [kPa]	150 [1034]								
Nominal Module Feed Pressure psig [kPa]†	95 [654.6]	100 [689]	103 [709.7]	104 [716.6]	96 [661.4]	97 [668.3]	101 [695.9]	95 [654.6]	101 [695.9]
Max. Product Pressure psig [kPa]	40 [275.6]								
Inlet Pressure Min., dynamic psig [kPa]	20 [137.8]								
Maximum, dynamic psig [kPa]	50 [344.5]								
Operating Temp °F [°C]	33-100 [1-38]								
Recovery (%)*									
Design	25	50	50	50	50	50	50	25	50
Minimum	15	15	40	40	40	40	40	15	40
Salt Rejection, Nominal (%)	98								

†Calculated using a 0.85 fouling factor

\*Nominal capacity based on new RO membranes operating on a properly pretreated feed water of 500 ppm TDS as NaCl, 77 °F (25 °C), Silt Density Index (SDI) below 3, and supplying water to atmosphere. Productivity will vary depending on the actual feed water quality and temperature.

# RO Installation

## Unpacking the RO

This manual, the warranty, and registration card are packed in the control assembly box.

**NOTICE** Examine each unit component carefully to check for loose or damaged parts. Report any apparent or concealed shipping damage to the freight carrier immediately.

## Materials Required

To install the system, the following items are required:

1. Level
2. Drill
3. Screws for mounting the bracket for the main plumbing assembly
4. Screwdrivers, including a small, flat-bladed (1/8" wide) screwdriver for wiring
5. Adjustable wrench
6. Tubing;  
All—Nat 1/2" Feed Water and Product Water Tubing  
All—Nat 3/8" Product Concentrate (Waste) Water Tubing
7. Bucket calibrated for taking flow rates
8. Clean rags
9. Thermometer
10. Portable Total Dissolved Solids meter
11. Safety glasses

## Unpacking

The reverse osmosis unit requires some assembly. Please check your order thoroughly to make sure you have the following items. Refer to the table for box quantities.

- Pump/Motor Panel
- Housing Assemblies
- Membranes
- Fitting Kit

	T-250	T-500	T-750	T-1000	T-1200	T-1700	T-2200	T-2000F	T-4000F
Motor Panel Assy	1	1	1	1	1	1	1	1	1
1-2.5"x21" Membrane Housing assy	1		1						
2-2.5"x21" Membrane Housing assy		1	1	2					
1-2.5"x40" Membrane Housing assy						1			
2-2.5"x40" Membrane Housing assy					1	1	2		
1-4"x40" Membrane Housing assy								1	2
Module 2.5"x21"	1	2	3	4					
Module 2.5"x40"					2	3	4		
Module 4"x40"								1	2
Tube Kit	1	1	1	1	1	1	1	1	1

## Location

T Series units are designed for wall mounting so that all components are accessible for maintenance and monitoring.

The wall you choose for mounting the unit must be capable of supporting at least 130 pounds. See the assembly section below for installation detail.

A 120 VAC/60 Hz/1 Phase grounded electrical receptacle with 15 amp fuse protection is required for use with the six-foot, three-wire power cord.

**NOTICE** Do NOT use any bolt size smaller than 1/4" diameter.

The unit must be located near a drain able to handle 10–20 gallons per minute (37.9–75.8 liters/min). This is in addition to the flow from any other water treatment equipment.



**CAUTION!** The system must not be located near any corrosive chemicals which may cause failure of the plastic or metal parts of the unit. In addition, do not locate the unit where the temperature may exceed the feed water temperature limits.

## Assembly

### Concrete Wall Installation

Refer to Figure 5 to install the RO system to a concrete wall. Place the unit against the wall, level the unit and mark the wall through the mounting holes. Drill the holes in the wall and mount the unit. Horizontal holes are on 16" centers. Vertical holes are on 2" centers.

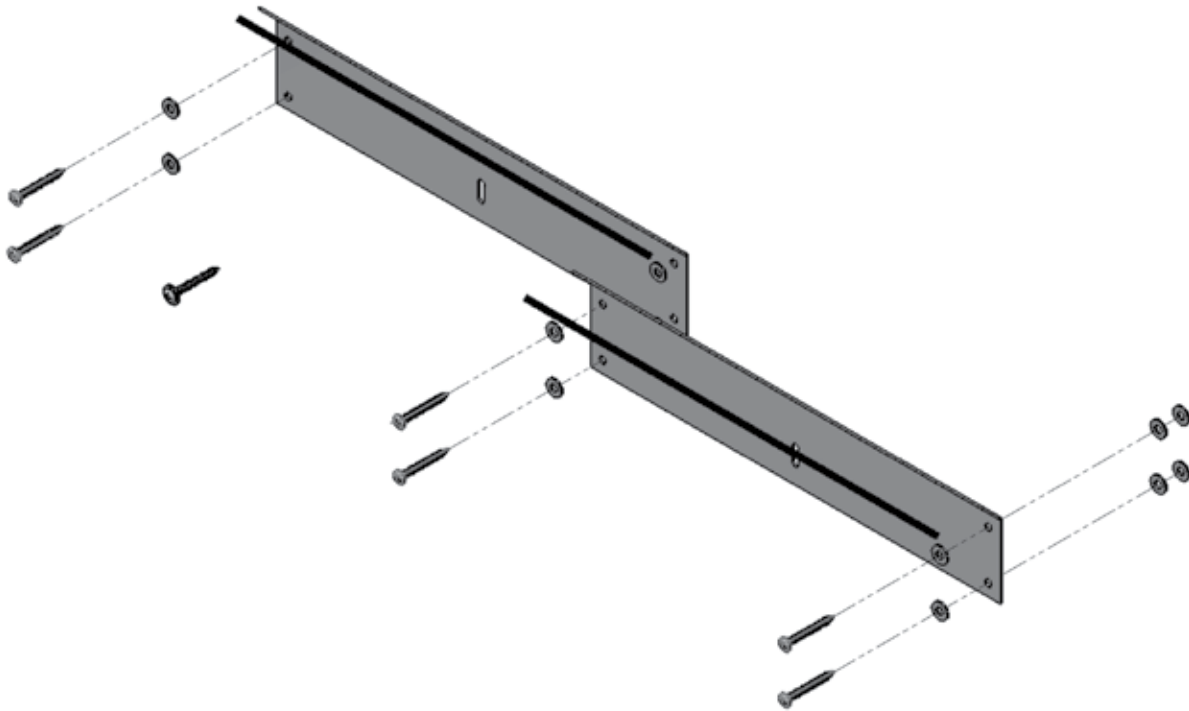

Figure 5. RO wall assembly bracket kit, PN 95742 (included with unit).

## Wall Mounting Kit (optional)

If the wall is not concrete and wall mounting is necessary, a wall mounting bracket kit is available. The bracket has holes for mounting on 16", 18", and 20" centers. Use bracket PN 95743 for all models.

Place the bracket adapter (Figure 6) on the wall with the flat side towards the wall. Level the bracket adapter and mark the wall through the appropriate holes. Drill holes in the wall and mount the bracket adapter. Assemble the wall brackets (Figure 6) to the bracket adapter. Mount the pump/motor assembly and the membrane assembly to the brackets.

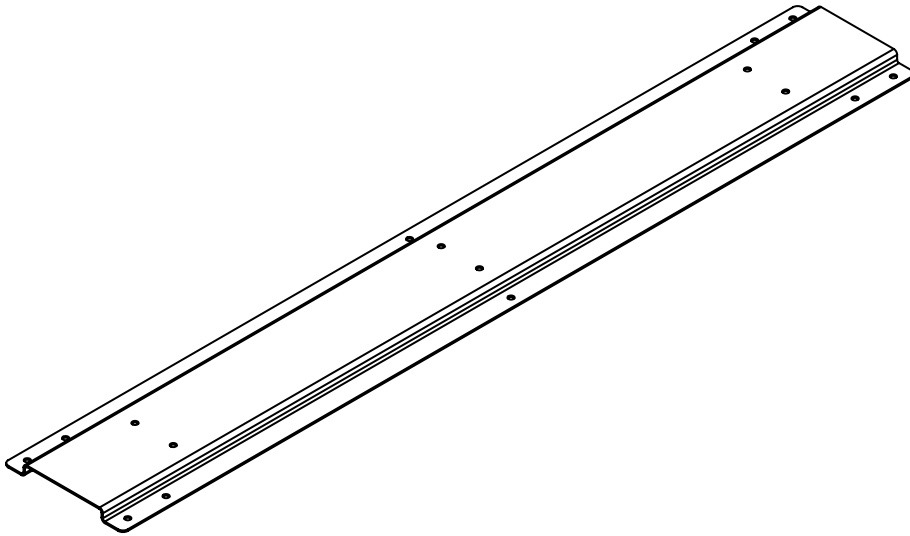

Figure 6. Optional Wall Mount Bracket.

## Stand Mounting (optional)

If the RO unit requires floor mounting, a rigid steel stand (PN 95744, Figure 7) is available. Wall mount brackets are used with floor stand to mount unit and membranes.

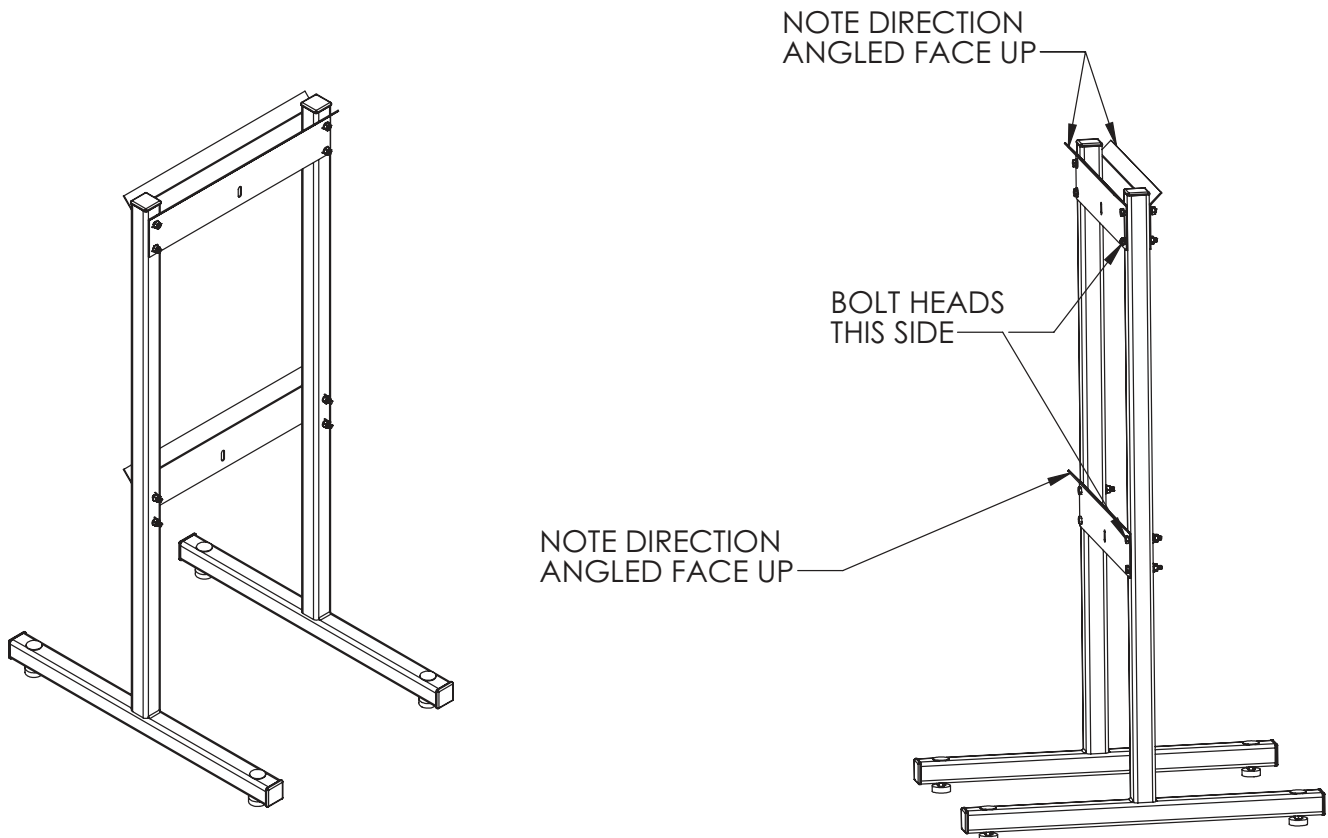

Figure 7. T Series RO floor assembly.

## Pump/Motor Panel

Hang the pump motor panel on the mounting bracket. The top edge of panel hooks on to the bracket. See Figure 8.

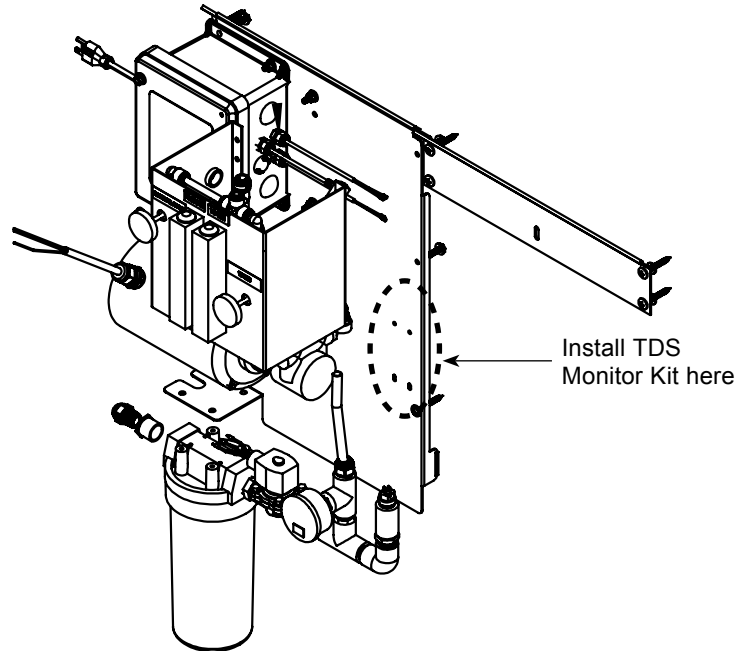

Figure 8. Pump motor panel hanging on mounting bracket.

## Fittings

Locate the Membrane Fitting Kit that was shipped with the unit. This kit includes all the fittings needed to connect the membranes to the pump/motor panel. Refer to Figure 12 on page 14 for the model you are installing and follow the tubing diagram. Detailed drawings of the fittings and housings can be found in the parts section.

## Prefilter Cartridge

1. Locate the prefilter cartridge packed with the main unit.
2. Unscrew the prefilter bowl.
3. Lubricate the seal ring with silicone lubricant as required.
4. Remove the paper wrapper from the cartridge, place the cartridge in the bowl, and screw the bowl onto the head.

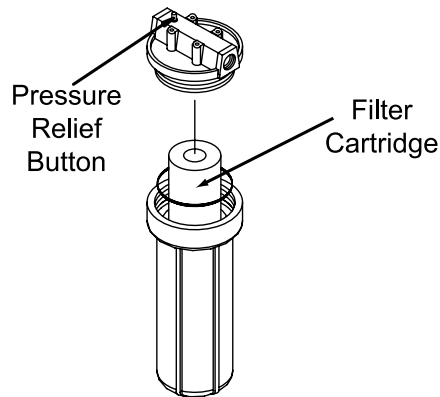

Figure 9. Installing the Prefilter.

## Membranes

### Replacing RO Membrane

The RO membranes are already loaded in the membrane housings. For replacing the RO membranes, follow the procedure below. Take care to not damage the end cap O-rings or membrane brine seal.

The membranes are shipped in a sealed package. Use extreme caution when opening the package with a sharp instrument. Any damage to the membrane can cause poor quality coming from the unit.

1. The membrane housings have directional arrows on them that indicate direction of flow. Install the membranes in the direction of flow. Open the housing end opposite the direction of flow.
2. Remove the end caps from all vessels by removing the two Allen head screws that hold down the retaining clips. The clips are pushed into an internal groove in the housing, so completely remove the screws so the clip can be slid out of the groove. Note placement of the caps to assure reinstallation in the same orientation.
3. Check the O-ring seals on the membrane and end plug, and the membrane brine seal for damage. If an O-ring is cut or crimped, it may cause high flow and poor quality. Replace any suspicious O-rings.

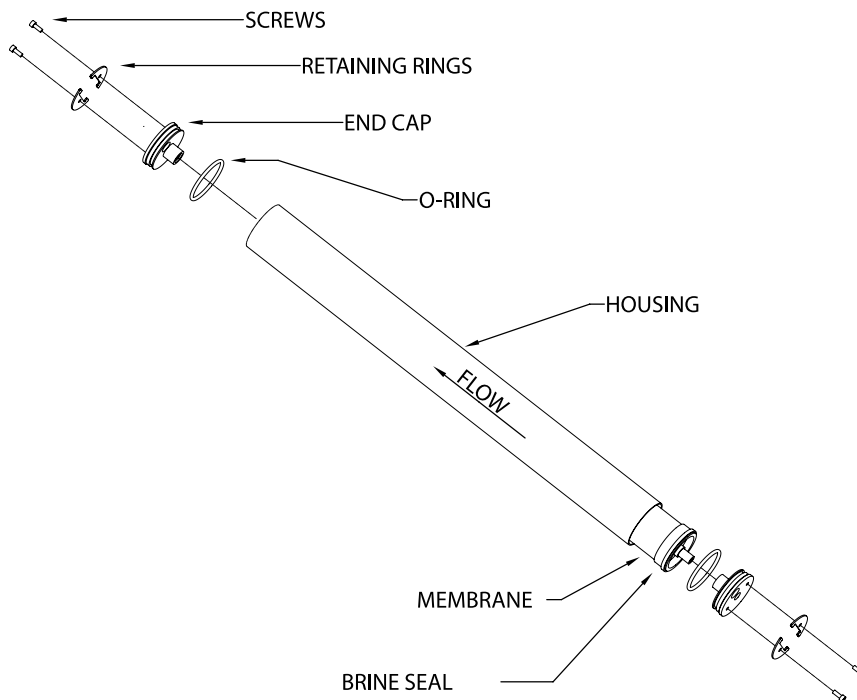

Figure 10. Membrane and its housing.

4. Remove a new membrane from its plastic bag. Lightly lubricate the O-rings with a silicone-based lubricant or use a mixture of 70 percent glycerin and 30 percent water.



**CAUTION! Do not use a petroleum-based lubricant. It will damage the synthetic rubber and the membrane.**

5. Install the membrane so the brine seal will be facing the incoming feed to the vessel. Flow direction is indicated by the arrow on the outside of the membrane vessel.
6. Lubricate the O-ring on the end plugs with a silicone-based lubricant or use a mixture of 70% glycerin and 30% water, then re-install the end plugs in to the vessels same as the original orientation. Reinstall the retaining clips.
7. Repeat for the remaining membrane housings. There may be from one to four housings depending on the model.
8. The membranes can now be hung from the membrane hanger. If there are an odd number of membranes, install the assembly with two membranes closest to the pump/motor panel. (T-750, T-1700).

# Tubing Configuration

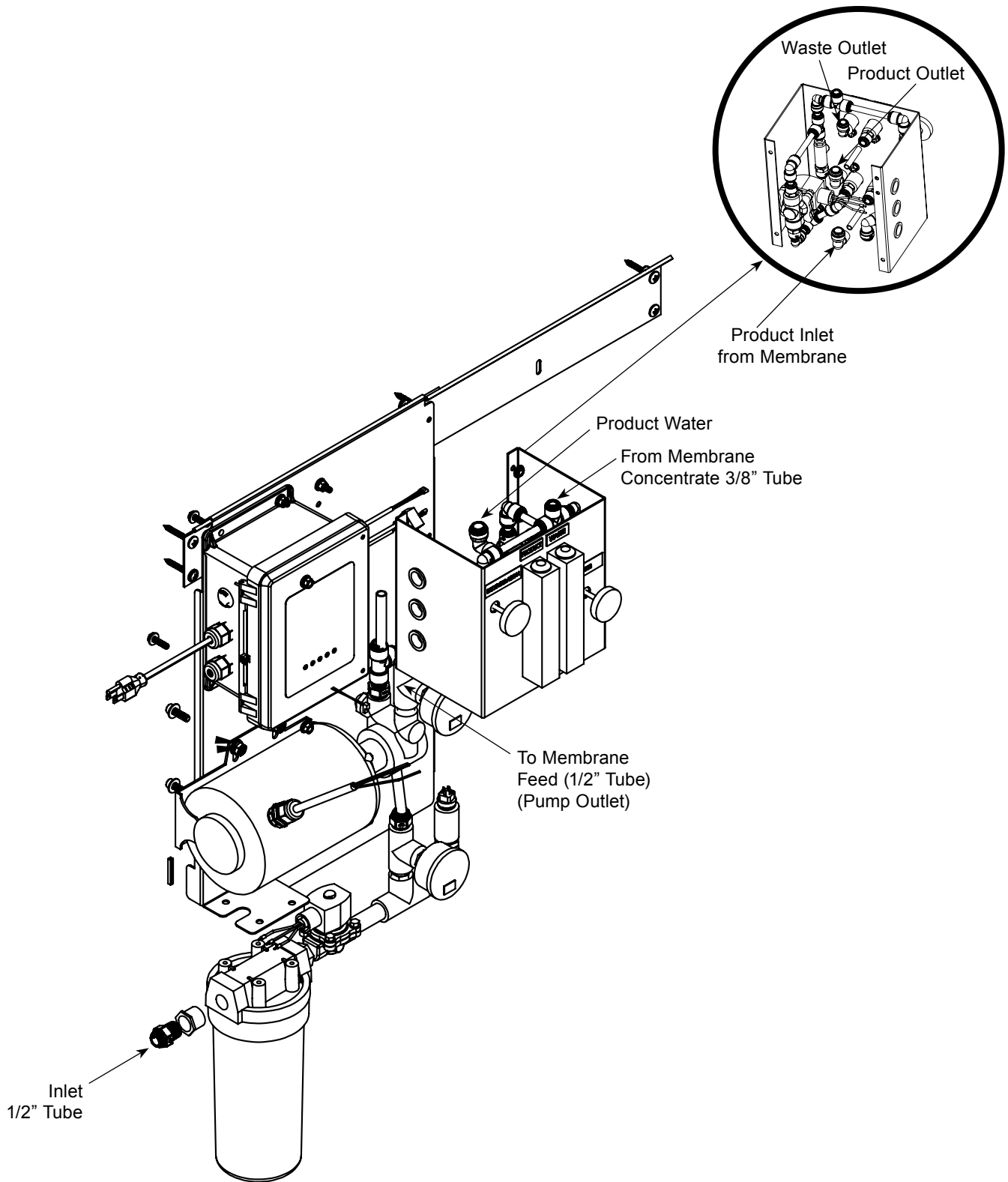

Figure 11. T Series tubing configuration.

# RO Module Tubing

For 3-D tube fitting diagrams, see the "RO Parts Diagrams and Lists" section.

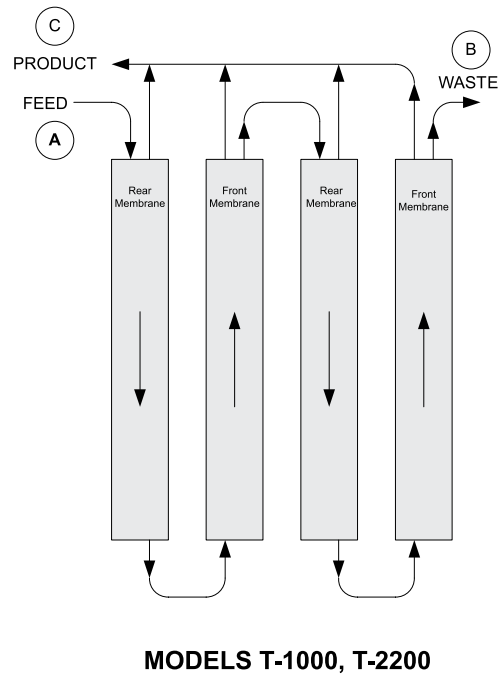
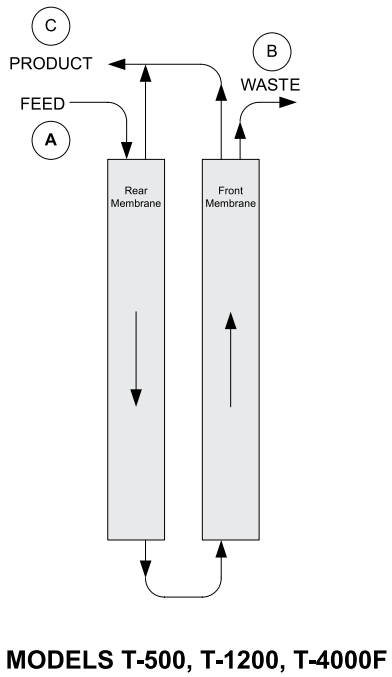
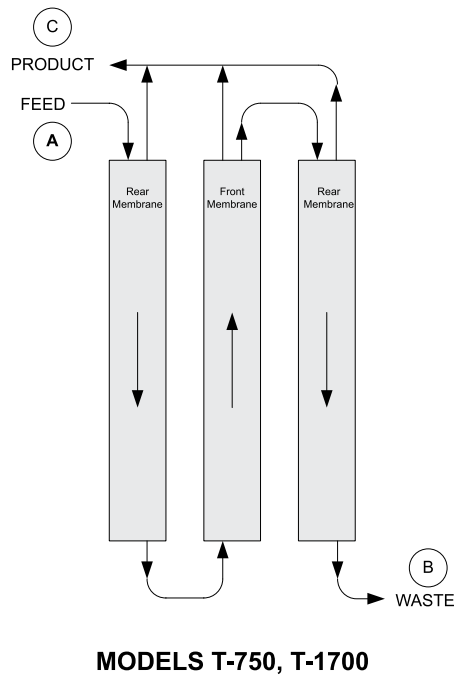
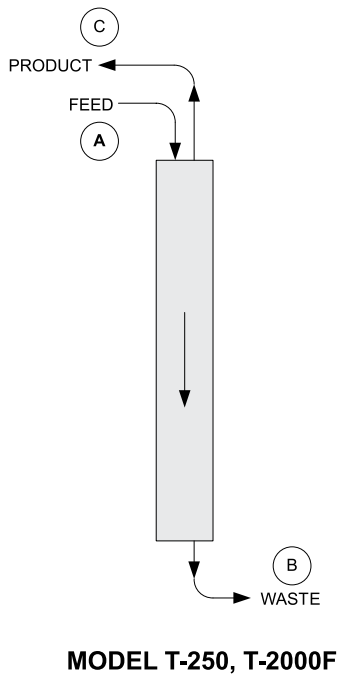

Figure 12. RO Module Tubing.





**WARNING! The system must be grounded. An improperly grounded unit could cause injury from electrical shock!**

## Plumbing Installation

Refer to the appropriate hydraulic schematic on page 3 for further information.

### Feed Water Connections

Connect pipe or tubing to the Feed water inlet. Observe the following:

1. To minimize pressure loss, the pipe or tubing size should be at least 1/2".
2. Install optional pressure gauges (quantity 2 of PN 101051) before and after the pre-filter to measure the pressure differential across the filter cartridge.
3. Install a tee, with a shutoff valve on the branch, before the feed flow meter to provide a connection for introducing cleaning solutions.
4. If necessary, install a pressure regulator (100 psi downstream max. setting) in the inlet plumbing, to assure constant pressure and to prevent harmonic vibration.
5. Install a shutoff valve in the inlet plumbing to simplify maintenance and service.
6. If the feed water can be used for a short period, install bypass plumbing around the unit.

### Concentrate Water Connections

1. Direct 3/8" piping to drain from the outlet of the unit.
2. To prevent siphoning of the water in the unit to drain, raise the concentrate piping above the level of the modules and provide an anti-siphon loop.



**WARNING! An air gap must be provided between the end of the concentrate tubing and the drain to prevent back-siphoning of drain contents.**

### Product Water Connections

The product water exits the unit at the product flow meter on the front side of the unit. Connect the product tubing to the fitting on the flow meter.



**CAUTION! This unit produces high quality product water. This water can be contaminated by plumbing following the unit or it can corrode the plumbing. Use only plumbing components of inert material that are compatible with the application.**

The connection of the main product tubing to service plumbing will depend on how the product water will be stored.



**CAUTION! Reverse osmosis elements will fail immediately if product water is allowed to flow backward into the unit.**

## Pressurized Storage Tank

The product water can be stored in a pressurized storage tank with the reverse osmosis unit controlled by a pressure switch. Use the same components used for direct feed (see Figure 13) with the addition of a pressure switch which needs to be wired to the control panel (see Figure 17 on page 27 for RO standard wiring).

## Non-Pressurized Product Water Storage Tank

Connect the product tubing to a bulkhead fitting at the top of the storage tank.



**CAUTION!** The highest point of the tubing should not be higher than four feet above the top of the reverse osmosis modules, or the elements may be damaged.

Depending on the type of application, a level control may be required to turn the unit off when the storage tank is full. Install the level control according to the instructions provided with the control. Refer to the wiring section in this manual for electrical connections.

**NOTICE** If a repressurization pump is used, an additional level control is recommended to prevent the pump from running dry if the storage tank is empty.

To maintain high water quality, a hydrophilic air vent filter, vacuum breaker, pop-off valve, ultraviolet lamp, and pressure relief valve may be required.

## Direct Feed

If the product water is to be used directly, without storage, a few precautions are necessary to prevent damage to the elements. Install a pressure gauge, pressure relief valve, and a normally-open (“dump”) solenoid in the product water line as shown in Figure 13. The pressure gauge will allow the operator to monitor the product water pressure. The relief valve, which should be set to open at 40 psig, will prevent the product water pressure from exceeding 40 psi. The dump solenoid will relieve all pressure when the unit is off.

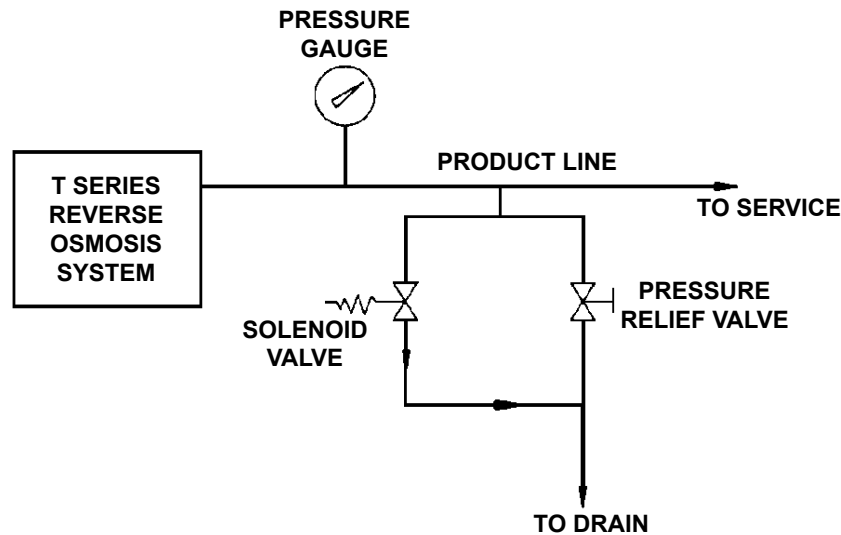



Figure 13. Direct feed connection.

Wire the direct feed/pressurized storage solenoid valve in parallel with the motor.

**NOTICE** Install a check valve after these valves in case the service line remains under pressure. Product back pressure will decrease the net pressure pushing water through the reverse osmosis elements. Therefore, the flow of product water will decrease.

## Electrical Installation

	<b>CAUTION!</b> Observe the cautions listed below before the electrical installation of the controller. Failure to do so might cause permanent damage to the RO controller.
---	---

	<b>CAUTION!</b> Before performing any electrical wiring refer to the electrical schematics.
---	---

	<b>WARNING!</b> Disconnect ALL power supplies when performing any electrical wiring.
---	--

A 120 VAC/60 Hz/1 phase grounded electrical receptacle with 15 Amp fuse protection is required for use with the eight-foot, three-wire power cord..

	<b>WARNING!</b> Do not remove grounding prong! An improperly grounded unit could cause injury from electrical shock.
---	--

## Pre-Installation Recommendations

- Follow the local electrical code requirements.
- Be sure electrical power is off and disconnected at the source before completing any wiring/cabling connections.
- DO NOT include any T controller wiring cables in any conduit or raceway containing other 120-volt or higher circuits.
- Maintain a distance of at least 10 feet between the T controller and any electrical distribution panels, raceways carrying 300 volts or more.
- Use the cabling provided. Failure to do so may affect performance of the T controller adversely.

## High Voltage Connections

To open the control panel, unscrew the door screws in the counter clock-wise direction and pull the hinged door.

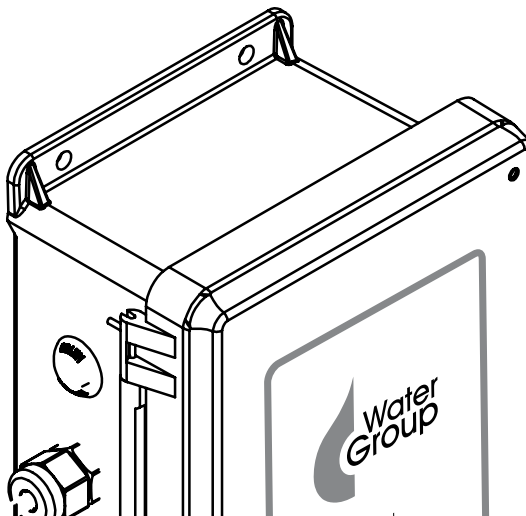

Figure 14. T Series control panel door.

The high voltage terminal strip is located on the circuit board (Figure 15). This terminal strip is pre-wired to the power cord, motor power cord and the solenoid valve.

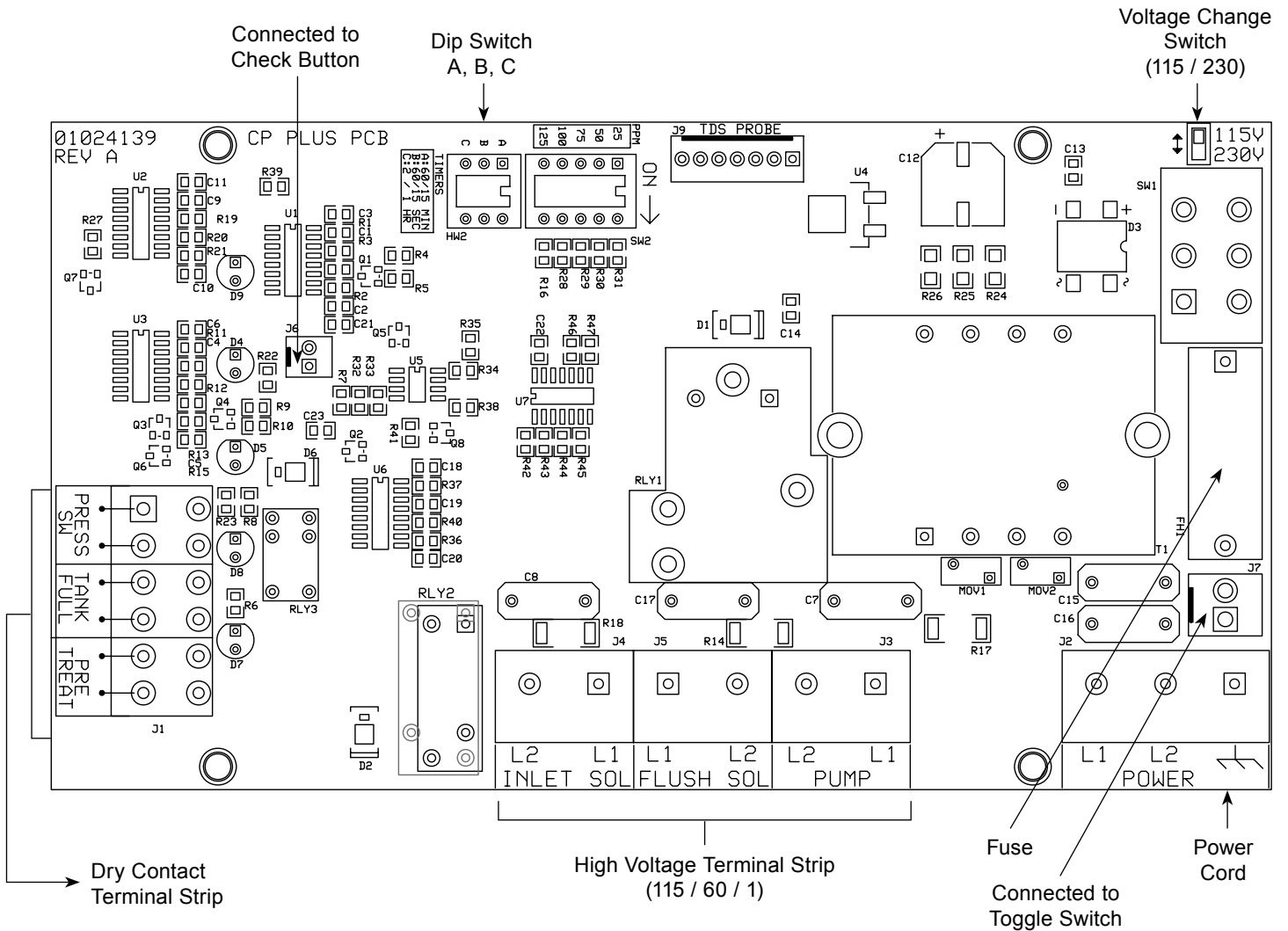

Figure 15. T controller circuit board.

### Dump Solenoid Connection

For direct feed applications, the dump solenoid is wired to the 120-volt motor cord contacts L1 and L2. When the motor is running the dump solenoid valve is closed. When the unit shuts down, the dump solenoid valve opens to drain.

### Dry Contact Connections

The dry contact terminal strip is located on the bottom right of the circuit board (Figure 15). This terminal strip accepts dry contact switch signals capable of handling 50 mA at 12V.

# Accessories

## Level Control

The RO controller provides a Level Control High switch.

The Level Control connections are located on the controller board. It is labeled “TANK FULL” on the main circuit board.

This signal is Normally Closed. When OPEN it indicates that the atmospheric storage tank is FULL (or that a Pressurized storage tank is at FULL PRESSURE.)

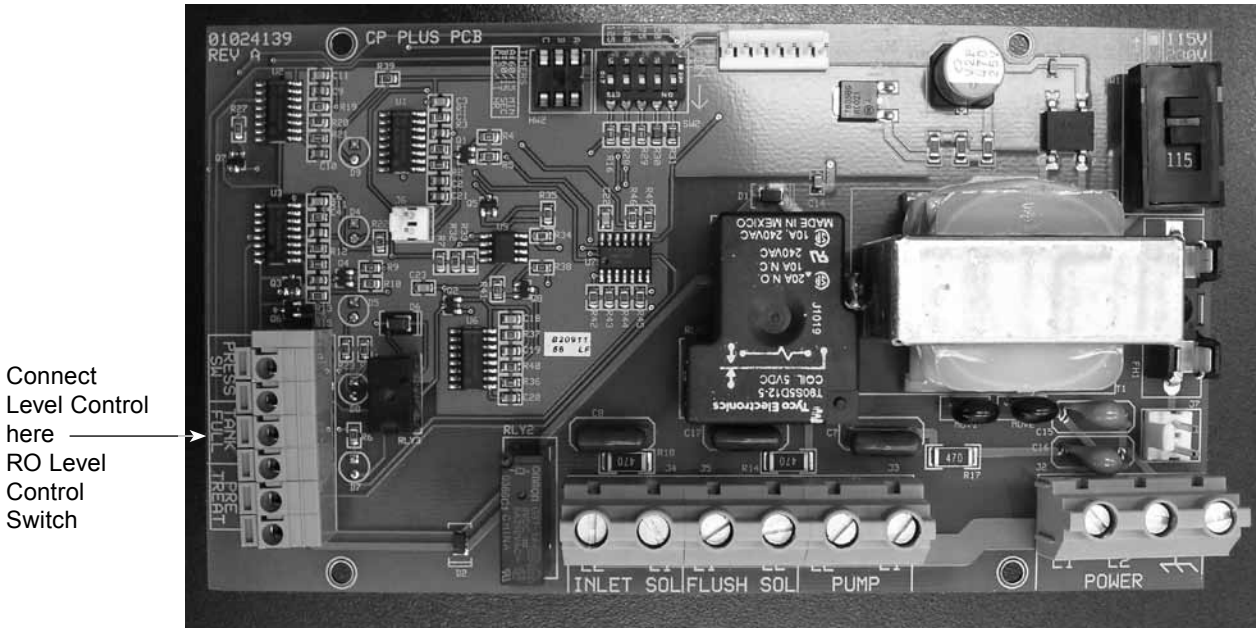

Figure 16. RO level control switch.

## Storage Tank Setup When Using a Single High Level Float Switch

Connect the level control (or pressure switch) to the TANK FULL terminals (see Figure 16). These terminals are intended for dry-contact wiring using 18-24ga wire. Remove the installed jumper wire when making this connection.

When this event occurs, the system immediately stops making RO water and the pump will turn off and close the inlet solenoid. It will remain off until this condition no-longer exists and then it will re-open the inlet solenoid, wait one minute and then start the pump to return to the “make water” condition.

**NOTICE** Do not apply power to these terminals. Use dry contacts only.

## Pretreatment Lockout

The controller allows an external contact closure to cause the RO to go into a “pre-treat lockout” condition. This signal is Normally Closed. When OPEN it indicates that the system should STOP because a piece of pretreatment equipment is in a regeneration state.

When this event occurs, the system immediately stops making RO water and the pump will turn off and close the inlet solenoid. It will remain off until this condition no-longer exists and then it will re-open the inlet solenoid, wait one minute and then start the pump to return to the “make water” condition.

## Flush Modes

### Line Pressure Front Side Flush Prior to Startup

When main power is first applied to the T controller, the controller will first wait for a one-hour delay (when dip switch A is OFF) and will then open the RO inlet solenoid valve and waits for an additional period of 1 minute. During this 1 minute, feed water under line pressure enters the RO, passes thru the pump and flushes through the upstream (feed water side) of the membranes and then passes to drain. When the 1 minute time is elapsed, the controller checks to see if there is sufficient incoming water pressure to operate the RO. If there IS pressure, the controller turns on the main pump and the RO begins to produce permeate water. If there IS NOT sufficient pressure, the entire process starts over beginning with the one-hour delay.

### Line Pressure Front Side Flush Every Two Hours of Continuous Make Water

The unit will stop when it has been in a continuous make-water operation for two hours (if dip switch C is OFF). The pump will remain off for 1 minute. During this time, the inlet solenoid valve will remain open and the system will perform a line-pressure front-side membrane flush to drain. At the end of the 1 minute, the system will return to the “make-water” mode.

### Powering the Control Box

There is a toggle switch located at the bottom of the control box for turning the controller ON or OFF.

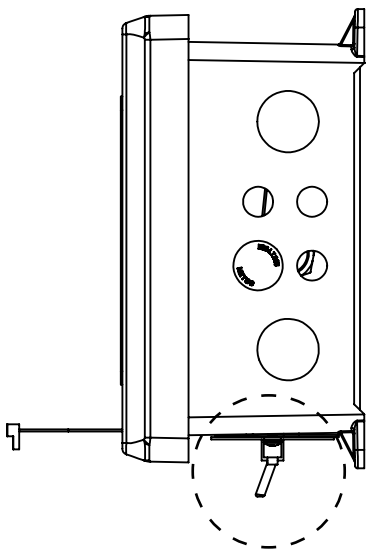

### Dip Switch Settings (A, B, C)

Dip Switch default settings are OFF from the factory.

	DIP Switch	Off (Default)	On
Power Up Start Delay	A	60 minutes	15 minutes
Flush Time	B	60 seconds	15 seconds
Pump Run Time	C	2 hours	1 hour

Power Up Start Delay is the duration of the delay between the unit being turned on and the inlet solenoid opening.

- Press the RUN NOW button to bypass the Power Up Start Delay
- This delay applies only upon initially turning the controller ON.

Flush Time is the duration between the inlet drain solenoid opening and the pump starting. This is also the duration of the Flush Time that is based on the Pump Run Time set by DIP switch C.

Pump Run Time is the duration that the pump runs before stopping to execute the Flush Time set by DIP switch B.

- The pump automatically restarts when the Flush Time has elapsed.

# Operation

## T Controller Board

The T controller board requires no programming and has the following capabilities:

- Control for 115 VAC
- Line pressure front side flush prior to startup
- Line pressure front side flush every two hours of continuous make water
- Shut-down upon loss of inlet water pressure and auto-restart
- Power-loss and return auto-restart
- Pretreatment lockout
- Storage tank level (or pressure) switch control
- Dip switches for selection of time for time flush
- Diagnostic indicator lights and “Run Now” button

Controller Label



The T controller is designed for simple control of small RO systems with the following characteristics:

- Inlet pressure switch to detect the presence/absence of feed water pressure to the RO
- Inlet solenoid valve, which is normally closed when the RO is off. The valve opens just prior to startup, remaining open as long as the RO is in a make-water mode

## Controller Behavior when Power First Applied

1. When main power is first applied to the T controller, the controller will first wait for a one-hour delay (if dip switch A is OFF).
2. The controller will then open the RO inlet solenoid valve, waiting for an additional one-minute period (if dip switch B is OFF). During this period, feed water under line pressure enters the RO, passes through the pump, flushes through the upstream (feed water side) of the membranes, and then passes to the drain.
3. Because the line pressure is expected to be fairly low (less than 100 psi) very little permeate water is created during this flush time. Instead, any high-TDS water on the membrane feed side is flushed to drain.
4. When the one-minute period has elapsed (if dip switch B is OFF), the controller checks to see if there is sufficient incoming water pressure to operate the RO.
  - a. If there IS pressure, the controller turns on the main pump and the RO begins to produce permeate water.
  - b. If there is NOT sufficient pressure, the entire process starts over, beginning with the one-hour delay.
  - c. As long as there is applied power and water pressure is being supplied to the unit, the RO will repeat this delay, flush, and attempt to start cycle indefinitely up to 24 restart attempts per day.
5. Once the controller successfully enters the make-water mode, it will continue to operate the pump and produce RO water until one of the following five events occurs:
  - Tank Full switch indication
  - Pretreatment lockout indication
  - Loss of electrical power
  - Loss of inlet pressure
  - Two-hour continuous make-water timer expiration (if dip switch C is OFF)

When any of these five events occurs the system immediately ceases making RO water. The pump will turn off and close the inlet solenoid.

6. If the unit has stopped for either tank full or pretreatment lockout conditions, it will remain off until these conditions no longer exist. The unit will then reopen the inlet solenoid, wait one minute, and then start the pump to return to the make-water condition.
7. If the unit has stopped because of either an electrical power loss or loss of inlet pressure, the system will follow the behavior described in step 1.
8. If the unit stops because it has been in a continuous make-water operation for the previous two hours (if dip switch C is OFF), the pump will remain off for one minute. During the time, the inlet solenoid valve will remain open, and the system will perform a line-pressure front-side membrane flush to drain. At the end of the minute, the system will return to make-water mode.



# Initial Startup

1. Open the feed water supply valve.
2. Direct the product water tubing to drain.
3. Open the recirculation valve (HCV-1) fully counterclockwise, then close two turns.
4. Connect the system to the power supply. Turn the power switch to the ON position.

**NOTE** If the inlet pressure falls below 20 psi during operation, a booster pump will be necessary.



**CAUTION!** If the pump chatters loudly, it is starving for water (cavitating). Turn the unit OFF immediately to prevent pump damage. Correct the low pressure condition before proceeding.

5. Check for leaks at all tube fittings and threaded joints.
6. Set the inlet pressure regulator (installed ahead of the Pre-filter) to 10 psig (69 kPa) below the minimum reading shown on the inlet pressure gauge, but no lower than 20 psig. This will allow for pressure variations in the feed water.
7. Slowly close the recirculation valve until the desired (normalized) product flow rate is attained. Check again for leaks.
8. Allow the unit to run so that the shipping solution (sodium bisulfite and glycerin) is flushed from the system. Test the concentrate water for sulfite; continue flushing until no sulfite is detected.



**CAUTION!** As the concentrate flow is reduced, the system pressure will increase. Open the system pressure control valve as required to prevent the system pressure from exceeding 150 psi (1034 kPa). Excessive pressure will damage the pump and may cause property damage.

9. Measure the product flow. Adjust the feed pressure with the system pressure control valve until the product flow is approximately 10% higher than the flow required for the application.



**CAUTION!** DO NOT exceed 150 psi (1034 kPa) or the pump may be damaged. The fittings and tubing may also fail and may cause property damage.

**NOTICE** By adjusting the feed pressure as low as possible to meet the application requirement, the service life of the pump and RO elements will be optimized. The system should run continuously, rather than go through frequent start/stop cycles. Do not exceed specified product flow rate!

10. Once all the desired flows are set, allow the system to run for approximately 30 minutes, and then record the following measurements using the units gauges (U) and your instruments (I):

- a. Feed Water Temperature, °F (I) \_\_\_\_\_
- b. Feed Water SDI (I) \_\_\_\_\_
- c. Feed TDS, ppm (I) \_\_\_\_\_
- d. Inlet Pressure, psig (U) \_\_\_\_\_
- e. System (pump outlet) pressure, psig (I) \_\_\_\_\_
- f. Product Pressure, psig (I) \_\_\_\_\_
- g. Concentrate (waste) flow, gpm (a-h) \_\_\_\_\_ x TCP = \_\_\_\_\_
- h. % Recovery (see page 5) \_\_\_\_\_
- i. % Rejection (see page 5) \_\_\_\_\_

<sup>1</sup>TCF = Temperature Correction Factor. Refer to Table 2 on page 46 in the Service and Maintenance section for this value.

11. Turn the power switch OFF. Connect the product tubing to the service plumbing.

12. Test the operation of the pressure switch by closing the inlet water supply valve. The unit should shut off immediately, and the Low Pressure light should turn on.

	<p><b>CAUTION!</b> If the unit does not shut off, turn the unit OFF immediately to prevent pump damage. Disconnect electrical power source, then check the wiring and replace the switch, if necessary.</p>
---	---

13. Open the inlet water supply valve. The unit should restart and the light should go out.

14. If connected, test the storage tank level control shutdown and the pretreatment lockout function.

### Normal Operation

During normal operation, the system usually will start up and shut down based on signals from a level control or pressure switch. Adjust the feed pressure as required (no higher than 150 psig (1034 kPa) to maintain a constant product flow. Record the performance data regularly and compare it to the performance on initial start up. If any changes are noticed, the product flow should be normalized to determine if cleaning is required (see Product Flow Calculations in the Service and Maintenance section).

## Product Flow Calculations

The product flow rate depends primarily on feed water pressure, product water pressure, and temperature. However, in most applications the temperature and pressure are lower, so the product flow rate is lower than the nominal flow rate. The actual flow rate must be converted to flow under standard conditions, then compared to the initial performance (also converted to standard conditions) to determine whether the system is still working properly.

To convert the data to standard conditions,

1. Measure the product flow. Example: 1000 ml/min
2. Measure the feed pressure. Example: 120 psig
3. Measure the product pressure. Example: 5 psig
4. Subtract the product pressure from the feed pressure. Example: 115 psig
5. Divide the product flow by the result from step 4. Example:  $1000 \div 115 = 8.69$  ml/min/psi
6. Multiply the result from step 5 by 105. Example:  $8.69 \times 105 = 913$  ml/min
7. Measure the temperature of the feed water, then determine the temperature correction factor from Table 2. Example: At a temperature of 55°F, the factor is 1.54.

Temp. °F	Temp. °C	Correction Factor	Temp. °F	Temp. °C	Correction Factor
40	4.4	2.12	75	24	1.04
45	6.7	1.90	80	27	0.95
50	10	1.71	85	29	0.86
55	13	1.54	90	32	0.79
60	16	1.39	95	35	0.72
65	18	1.26	100	38	0.66
70	21	1.14			

Table 2. Temperature Correction Factors

8. Multiply the result of step 6 by the temperature correction factor. Example:  $913 \text{ ml/min} \times 1.54 = 1406 \text{ ml/min}$ .

**NOTICE** To convert ml/min to gallons per day, multiply by 0.38. For example,  $1406 \text{ ml/min} \times 0.38 = 534 \text{ gpd}$ .

9. Compare the current standardized flow to the initial standardized flow. If the flow has decreased by 10% or more, it is time to clean the elements.

Example: If the initial standardized flow was 570 gpd, and the current standardized flow is 470 gpd, the flow has decreased by 100 gpd, or 18% ( $100/570$ ) = 0.18. The elements should be cleaned.

10. If the problem cannot be corrected with the troubleshooting guide and assistance is required, please have the following information available when calling the dealer:
  - Product flow rate
  - Concentrate flow rate
  - Feed pressure
  - Product water quality
  - Feed water quality
  - Feed water temperature
  - Prefilter inlet and outlet
  - Product pressure

# Flow Diagram

## T Series Process Flow Diagram

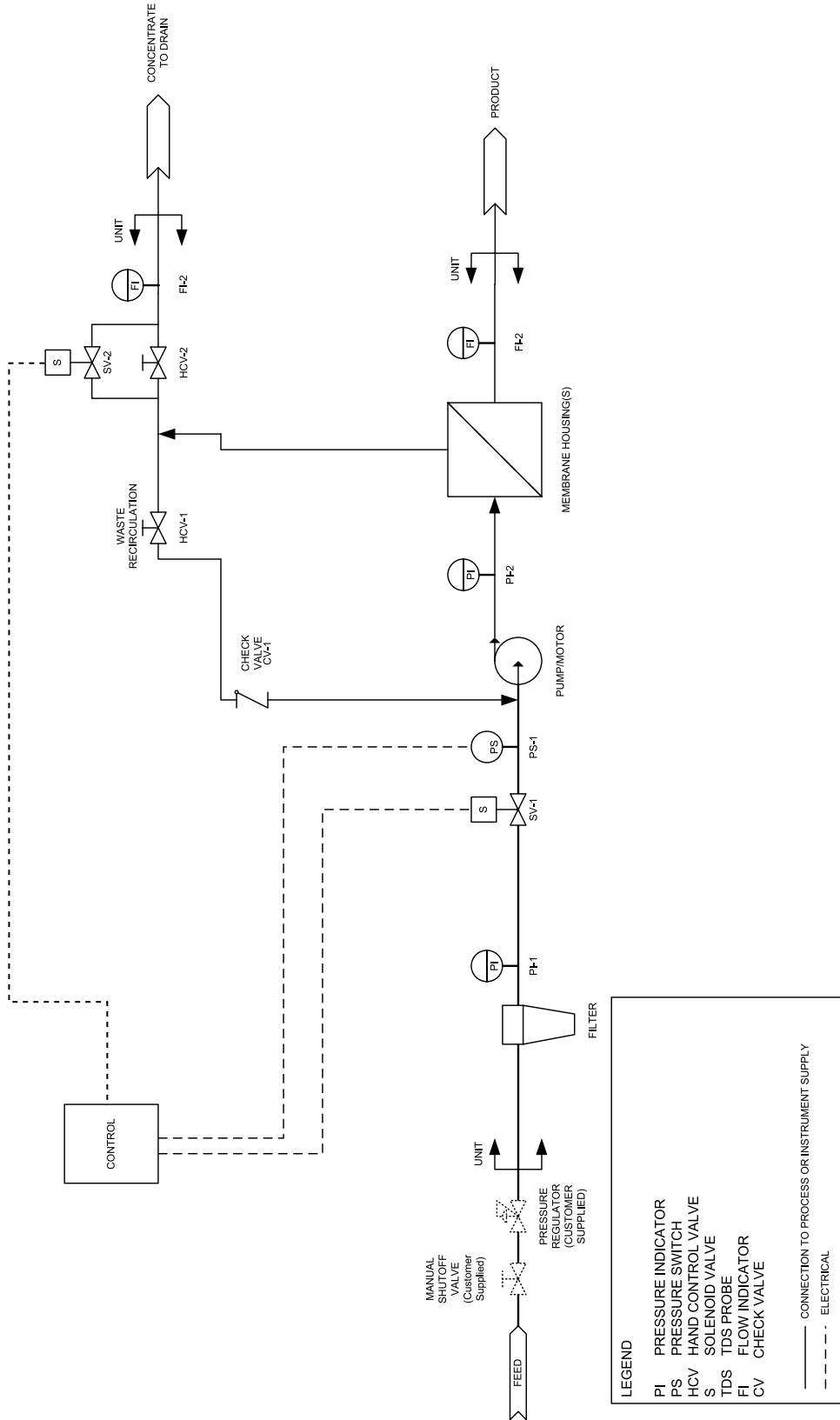

# T Series Wiring Diagram

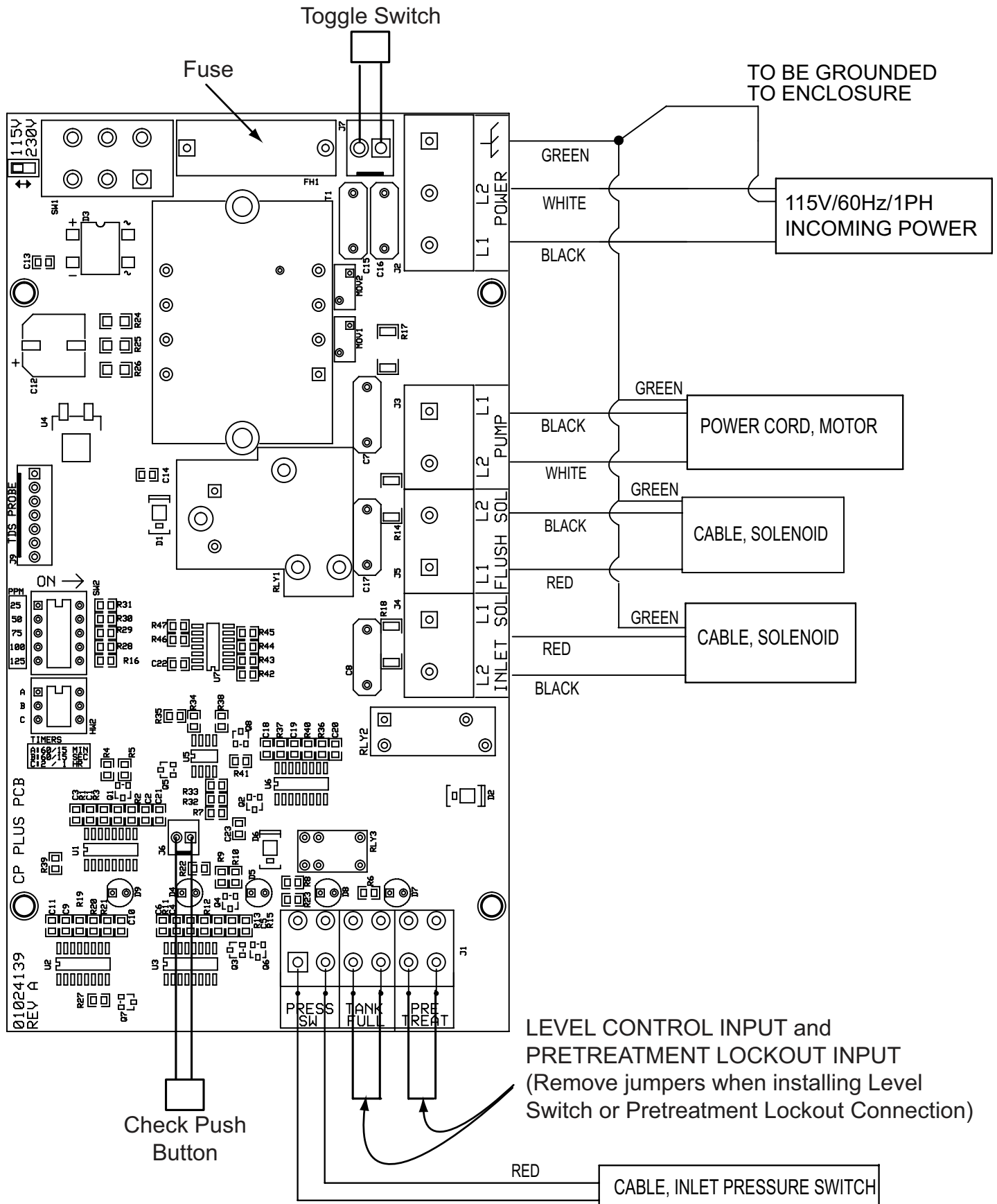

Figure 17. T Series wiring diagram.

# Service and Maintenance

## Serial Numbers

The T Series units have a serial number located directly behind the electronic controller on the side panel. Do not remove or destroy these serial number labels.

They must be referenced if you require repairs or parts replacement under warranty.

## Troubleshooting

Problem	Probable Cause	Solution
1. Unit does not start.	A. No power to unit.	A. Check circuit breaker.
	B. Low feed pressure.	B. Correct low pressure condition.
	C. Inlet solenoid failure	C. Replace solenoid
	D. Prefilter fouled.	D. Replace cartridge
2. Unit running but not holding high pressure.	A. Pump malfunction.	A. Replace pump.
	B. System pressure control valve malfunction.	B. Replace valve.
	C. Concentrate flow too high.	C. Check and adjust concentrate flow, replace tubing on A.
	D. Product flow too high.	D. Test modules.
3. Unit running but poor quality (less than 95% rejection)	A. Low pump pressure.	A. See 2.
	B. Module failure.	B. Replace modules. Check product line over pressurization.
	C. Concentrate throttling valve open.	C. Throttle valve down.
	D. Poor seal on end cap.	D. Check O-rings inside end cap. Replace O-rings if necessary.
4. Low quantity of product water.	A.-D. Same as 3.	A.-D. Same as 3.
	E. Cold water.	E. Install additional modules.
5. Excessive noise.	A. Air in the plumbing.	A. Check fittings for leaks. Purge air from system.
	B. Misaligned pump.	B. Remove pump and check for bearing wear.
	C. Harmonic vibration.	C. Install a pressure regulator ahead of the prefilter.
	D. Low feed pressure.	D. Increase feed pressure above 20 psig.
6. Inadequate product pressure (direct feed systems)	A. Low quantity of product water.	A. See 4.
	B. Demand for product water exceeds unit capacity.	B. Install additional modules.

## Using the Check Diagnostic Button

There is one small push button on the bottom of the T controller box, Check. The Check button is intended for use by service personnel. This button allows a service technician to remove power and/or simulate inlet pressure loss to the system without needing to wait one hour for the system to attempt to restart.

- Any time the system is in a one-hour delay mode, such as a one-hour delay immediately after providing electrical power to the board. Pressing the Check button will cancel the remaining delay. The unit will immediately open the inlet solenoid valve and begin the startup flush procedure.
- At any other time, such as during a flush or make-water operation, the Check button has no effect.

## Verifying Correct Operation of the T Controller RO System

1. Verify that the incoming line pressure is at least 30 psi.
2. Disconnect and then reconnect power to the T controller. Switch ON the Toggle switch located at the bottom of the controller housing. Verify that there actually is available power coming from the outlet—if not, check the circuit breaker panel. The “Power” LED will light up.
3. Press the Check button. The “Inlet Valve Open” LED on the T controller should light immediately, indicating that the inlet solenoid is activated. Sixty seconds later, another diagnostic light, indicating power to the motor, should activate.
4. If the LED sequence does not occur, it is possible that there is an input signal indicating pretreatment lockout, tank full, and/or inlet pressure switch. Eliminate each of the input signals as a source of the problem as follows:
  - a. Verify that the replaceable fuse element on the board (located near the 115/230 VAC selector switch) is not blown. Use a Volt-Ohm meter to verify that there is less than 10 Ohm of resistance through the fuse.
  - b. If the pre-treatment lockout and/or tank full input signals are NOT being used, verify that there is a jumper wire in place connecting the pair of level switches together.
  - c. One at a time, remove the two signal wires from the sensor for the level switches for inlet pressure, pretreatment lockout, and tank full sensor. Replace the signal wires with jumper wires. After installing the jumper wire press the Run Now button and follow step 3 above. If the board does not work, continue replacing signal wires with jumper wires and restart the startup sequence.

Replace the circuit board if all of the inputs are wired with jumpers and the system still does not function as described above.

## Prefilter Cartridge Replacement

The prefilter cartridges should be changed when the pressure drop across the prefilter increases by 15 psi (103 kPa). Refer to the diagram in the installation section.



**CAUTION!** The pressure after the prefilter should not be less than 15 psi (103 kPa), or the pump might be damaged.

## Replacing the Prefilter Cartridge

1. Disconnect power to the unit, then shut off the inlet water supply.
2. Unscrew the filter bowl.
3. Remove the old cartridge.
4. Clean the filter bowl with a damp cloth, rinse thoroughly.
5. Remove the wrappers from a new cartridge. Install the cartridge in the bowl, making sure it seats in the bottom of the bowl.
6. Check the O-ring seal for dryness and cuts. Replace the seal if necessary and use silicone lube as needed.



**CAUTION!** Do not use petroleum-based lubricants, because they destroy the synthetic rubber seal.

7. Screw the filter bowl back onto the filter head.
8. Turn on the inlet water supply.

## Membrane Replacement

Replace an element that has been damaged or cannot be cleaned. See Figure 18.

1. Disconnect power to the unit. Allow pressure to be completely relieved. Turn main feed line to RO off.
2. Remove retaining clips from both ends of all vessels.
3. Remove end caps from all vessels, with the tubing remaining in place. Note placement the caps to assure re-installation in the same orientation.
4. Remove the RO element from the housing. Note orientation of membranes to assure re-installation in same orientation. Brine seal will be facing the incoming feed to the vessel. Flow direction is indicated by the arrow on the outside of the membrane vessel.
5. Check the O-ring seals on the element and end plug, and the element brine seal for damage. If an O-ring is cut or crimped, it may have caused high flow and poor quality. Replace the O-rings and retest before replacing the entire element.
6. Remove a new element from its plastic bag. Lightly lubricate the O-rings with a silicone-based lubricant or use a mixture of 70% glycerin and 30% water.



**CAUTION!** DO NOT use a petroleum-based lubricant, because it will damage the synthetic rubber and the membrane.



7. Make sure the brine seal is located in the direction of the incoming feed to that vessel according to the flow arrow and the original membrane orientation.
8. Lubricate the O-ring on the end plugs with a silicone-based lubricant or use a mixture of 70 percent glycerin and 30 percent water. Re-install the end plugs in to the vessels same as the original orientation. Reinstall the retaining clips.
9. Refer to the section on Initial Startup for information on flushing the shipping solution form the new elements.

**NOTE Do not forget to enter the new values for flow, pressure, temperature, and TDS.**

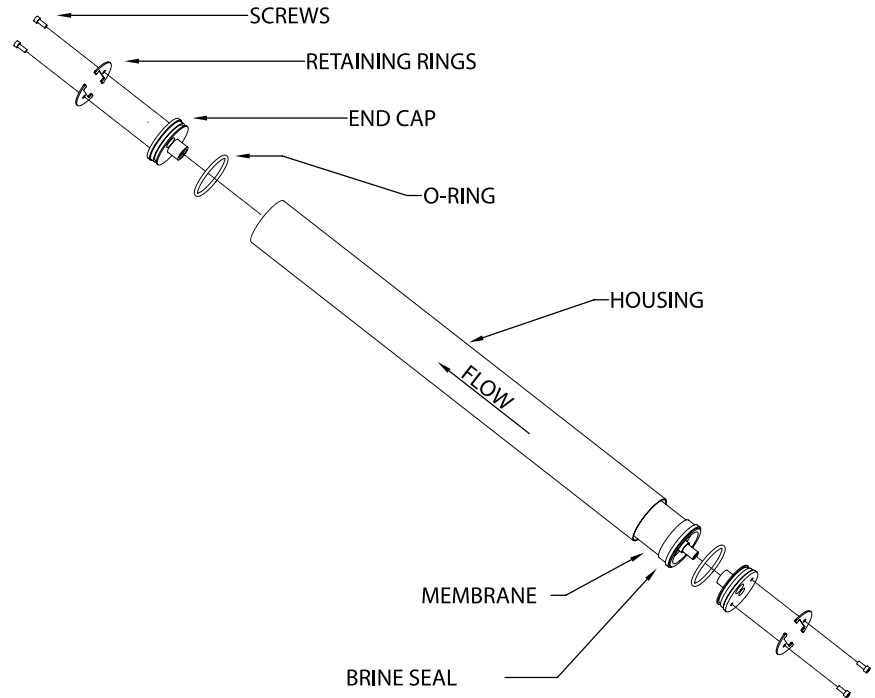

Figure 18. T Series membrane.

## Pump Replacement

The pump should be replaced when it cannot develop the pressure required to maintain the appropriate pressure. The most common cause of pump failure is inadequate pressure to the pump inlet. Therefore, correct any low inlet pressure problem before replacing the pump to prevent damage to the new pump. Replace the pump when it cannot develop the pressure required to maintain the desired product flow rate, up to the maximum pump pressure of 150 psig (1034 kPa).

To replace the pump:

1. Disconnect power to the unit, then shut off the inlet water supply.
2. Remove the tubing from the pump inlet and outlet.
3. While holding the bottom of the pump with one hand, loosen the screw on the coupling band securing the pump to the motor. The pump will drop down. Remove the coupling band.
4. Examine the pump shaft. If it is broken or rounded, remove the old shaft and install a replacement shaft. Examine the slot in the motor. If the slot is damaged, replace the motor.
5. Remove the plumbing fittings from the old pump, apply fresh Teflon tape, and install the fittings in the new pump. (Skip this step if replacing only the shaft.)
6. Place the coupling band over the shaft end of the new pump. Insert the pump shaft into the slot in the motor.
7. Observe the alignment of the pump against the motor, making certain the pump and motor flanges are in complete contact and are not skewed.
8. Make sure the clamp is fully seated around the entire circumference of the pump and motor flanges. Tighten the coupling screw fully, then loosen the screw 1/4 to 1/2 turn.
9. Rotate the pump so that the inlet and outlet ports point to the right. Verify that the pump is still aligned properly to the motor.



**CAUTION! If the pump is not properly aligned, the pump bearings will wear prematurely.**

10. Tighten the coupling screw using 15 to 30 inch-pounds of torque, then attach the inlet and outlet.

## Motor Replacement

1. Disconnect the pump from the motor as outlined in steps 1-4 in pump replacement section.
2. Disconnect the motor cord from the old motor.
3. Remove the pump and motor assembly from the mounting bracket by removing the four (4) nuts, lock-washers and washers, holding the motor onto the motor mounts.
4. Mount the new motor onto the motor mounts and secure with nuts and washers.
5. Wire the motor cord connections to the new motor as indicated on the wiring schematic on the motor label for 110 volt operation.
6. Reinstall the pump, fittings and tubing following steps 7 through 10 as outlined in the pump replacement section.

**NOTICE Some replacement motors may be pre-wired for 220 Volt operation at shipment. Refer to wiring schematic on the motor label and verify that the motor is wired for 110 Volt operation.**

## Sanitizing Modules

The modules may need sanitizing if either of the following conditions exist:

- The RO system is subject to bio-fouling and the operator wants to reduce the cleaning frequency.
- The water treatment application limits the microbial count in the product water.

	<b>CAUTION!</b> The bottom of the tank must be higher than the pump on the RO unit to prevent cavitation of the pump when solution is drawn from the tank.
---	--

<b>NOTICE</b> Replace the prefilter cartridges if they are discolored by iron.
--

The frequency of sanitization will depend on the frequency of bio-fouling or excess microbial counts. Once the frequency of the problem has been determined, sanitization can be scheduled for preventative maintenance. To sanitize the system, obtain a tank which will hold the sanitizing solution volume.

	<b>CAUTION!</b> DO NOT sanitize the system during the first 24 hours of operation. Formaldehyde will cause a significant decrease in product flow with new elements.
---	--

1. Disconnect power to the unit.
2. Disconnect the product tubing from the service line and direct it into a ten gallon bucket.
3. Plug in the unit. Fill the bucket with product water to the 4 gallon mark, then disconnect power to the unit.
4. Direct the product tubing to drain, then plug in the unit. Open (counterclockwise) the system pressure control valve until the system pressure is approximately 50 psig. Disconnect power to the unit.
5. Add 500 milliliters of 37 percent formaldehyde solution to the bucket for the T-250, T-500, T-750 and T-1000. Add one liter of 37 percent formaldehyde solution to the bucket for T-1200, T-1700, T-2200, T-2000F and T-4000F. Mix the solution well.

	<b>CAUTION!</b> Always use caution when handling any chemical. Refer to the material safety data sheet for recommendations in the safe handling of this chemical. The MSLS is available from the manufacturer of the chemical. Use the proper protective safety equipment.
---	--

6. Turn off the inlet water supply.
7. Connect tubing to the cleaning port fitting that was installed near the Pre-filter inlet, then open the cleaning port valve.

	<b>CAUTION!</b> Local codes may prohibit the discharge of hazardous materials to drain. If necessary, an extra tank can be used to neutralize the solutions before discharge to drain.
---	--

8. Remove wires from terminals 3 and 4 (Pressure switch) and install a jumper wire across those two terminals.
9. Place the end of the cleaning tube into the sanitization solution. Raise the bucket so that the bottom of the bucket is higher than the pump.
10. Plug in the unit. Allow the unit to draw in all but about 1/2" of the sanitizing solution. Do not allow air to be drawn into the system.

	<b>CAUTION!</b> If the unit vibrates severely, the pump may be cavitating. Disconnect power to the unit. Raise the bucket to ensure adequate pressure to the pump.
---	--

11. Disconnect power to the unit. Close the cleaning port valve. Open the feed water supply valve.
12. Allow the unit to sit undisturbed for at least two hours.

**NOTICE** If the unit is going to be left unused for up to three months, allow the solution to remain in the unit. If the unit will remain unused for longer than three months, sanitize the unit every three months.

13. To flush the unit, plug in the unit. Slowly close (clockwise) the system pressure control valve until the system operating pressure increases to the normal pressure. Increase pressure no faster than 5 psi per second.
14. Allow the unit to run for at least 30 minutes. Check the product water for formaldehyde using a Formalert test or equivalent. Continue rinsing until the formaldehyde level is lower than 5 parts per million (5 mg/L) and until the pH for the concentrate and product remains stable for five (5) minutes.
15. Disconnect power to the unit. Reconnect the product tubing to the service line. Remove the jumper installed in Step 7 and reconnect the pressure switch. The system is now ready for use.

## Testing

If the product flow calculations or NFLOW values show a loss of flow, or the product quality has become poor, one or more elements will require cleaning or replacement. Because poor performance might be due to only one element, test the product flow and quality from individual housings.

To test each element:

1. Disconnect the product tubing from the housing to be tested.
2. Plug in the unit, then measure the product flow and TDS from the test element.
3. Disconnect power to the unit and reinstall the tubing.
4. Continue testing the elements as needed to determine which should be cleaned or replaced.

## Cleaning

During the operation of any reverse osmosis system, dissolved solids and particulate matter are concentrated inside the module element. If these contaminants are present in relatively low concentrations, the concentrate flow from the system flushes them to drain. In most cases, water pretreatment such as filters and softeners will prevent the deposit of these contaminants.

When these deposits occur, there will be a decrease in the product water flow and quality. When these symptoms become excessive, the modules must be cleaned before they are permanently damaged.

To determine when cleaning is needed, compare the current system performance to the performance of the system when the reverse osmosis elements were new. Use Table 3 to obtain data and compare the performance of the system, “new” and “now” (record the data in pencil).

Test Data	Feed		Product		Concentrate	
	New	Now	New	Now	New	Now
Flow (gpm)						
TDS (ppm)						
Pressure (psi)						
Temp. (°F)						

Table 3. System performance—new vs. present.

**NOTICE** If new data is not available, use the specifications listed earlier in these instructions. However, keep in mind that the new elements may have exceeded these specifications, so performance may have decreased even if the unit still exceeds specifications.

In addition to differences in product flow and quality (TDS), determine whether there were any changes in concentrate water flow, feed water TDS, feed water temperature and feed or product pressures. Changes in these values provide clues to indicate the cause of any problems with the product water.

If there were changes in feed water temperature or pressure, the product water flow rates will have to be converted to flow rates under standard conditions (77° F and approximately 105 psig) in order for any comparison to be valid. Refer to the Product Flow Calculation section to calculate flow rates under standard conditions, then compare the converted values. A decrease in the product water flow may have been due only to a decrease in temperature or pressure, in which case cleaning would not be indicated.

If any change in the performance of the elements was not due to a change in operating conditions, it may be time to clean the elements. In general clean the elements:

1. When the product flow rate decreases by 10% (or when the feed pressure must be increased by 10% to maintain the same product flow), or
2. When the percent of rejection decreases below specification.

**NOTICE** Because strong chemicals are used to clean the elements, maintenance cleaning is not recommended. If the elements need to be cleaned frequently (more than twice a year), the pretreatment may be inadequate. Obtain a current water analysis and test the Silt Density Index and the Total Chlorine level of the water on-site to review what changes in pretreatment may be needed.

When cleaning is required, the type of material which is fouling the element should be identified, if possible. Refer to Table 4 to determine the possible causes of the performance change.

Percent Rejection	Flow		
	Low	Normal	High
Low	Hardness Scale	Hardness Scale (light) or Iron	Membrane Damage
High	Silt or Bio-fouling	—	Membrane Damage (light)

Table 4. Performance change possible causes.

For example, if the product flow is low but the percent rejection is normal, the likely causes of the problem are silt or bio-fouling. Please note that if the product flow rate has increased (with no increase in temperature or pressure) the likely reason is damage to the membrane, which cannot be repaired by cleaning.

Once the foulant has been identified, choose the recommended cleaning chemical(s) from Table 5.

Membrane Problem	Cleaning Chemical
Hardness Scale	Hydrochloric acid, phosphoric acid
Iron	Hydrochloric acid, phosphoric acid
Silt	Phosphoric acid and sodium hydroxide
Bio-fouling	Phosphoric acid and sodium hydroxide

Table 5. Recommended membrane cleaning chemicals.

Because phosphoric acid can be used by itself or in combination with sodium hydroxide to clean almost all types of foulants, it is generally recommended over hydrochloric acid when choosing a “stock” acid.

**NOTICE** Some municipal surface water supplies are treated with alum. Aluminum fouling results in low flow and, occasionally, in low rejection. If aluminum fouling is suspected, use only hydrochloric acid.

Use a pH meter to prepare acid and caustic solutions, and to monitor pH changes as the solutions react with any foulants.

Materials required:

1. Solution tank (50 gallon capacity, minimum), to prepare and store the chemical solution.
2. Tank stand, to elevate solution tank to level above pump.
3. Tubing 1/2" O.D. to connect cleaning adapter ahead of Pre-filter.
4. A pH meter.
5. A pre-filter cartridge (PN 26273).

Before proceeding record the "NOW" values in Table 3.

1. Disconnect power to the unit.
2. Place the solution tank on the tank stand. Connect the tubing to the cleaning adapter then place the other end of the tubing at the bottom of the solution tank.

**NOTICE** The tubing length should be as short as possible to prevent excessive pressure drop. Cut the tubing as required to minimize the length.

3. Remove the product tubing from the service connection and place the end in the solution tank. The concentrate tubing should still be directed to drain.
4. Replace the Pre-filter cartridge.
5. Plug in the unit. Fill the tank with 30-40 gallons of RO product water.



**CAUTION!** DO NOT turn on the RO system unless water can flow from the product and waste lines.

**NOTE** Soft water is an acceptable substitute for RO water. When the solution tank is filled, direct the product tubing to drain. Next, open the pump system pressure control valve until the system pressure is approximately 50 psig.

6. Disconnect power to the unit. Remove wires from terminals 3 and 4 (Pressure switch) and install a jumper wire across those two terminals.
7. Open the cleaning valve to allow feed water to displace air in the cleaning tubing, then close the inlet water shutoff valve.
8. Plug in the unit.



**CAUTION!** If the pump is noisy, cavitation is occurring and the pump will be damaged. Unplug the unit and check for any obstructions to flow. Reduce the pump pressure as required to prevent cavitation.

9. Record the pump pressure and measure the product water flow at low pressure. This flow will be used to estimate if cleaning has been successful. Disconnect power to the unit.
10. Add enough acid to the solution tank until the pH is between 2.0 and 2.5.

**NOTE** If the foulant to be removed is silt or a biofilm, use phosphoric acid.



**WARNING!** Acid and Sodium Hydroxide are strong chemicals that must be handled carefully to avoid injury. Wear protective clothing and have a source of water nearby to flush any spills.



**CAUTION!** Local codes may prohibit the discharge of acid and caustic solutions to drain. If necessary, an extra tank can be used to neutralize the solutions before discharging to drain.

11. Plug in the unit. After approximately 5 gallons have been drawn from the solution tank, disconnect power to the unit.
12. Allow elements to soak for 15 minutes. Plug in the unit. Draw another 5 gallons from the solution tank. Disconnect power to the unit.
13. Remove the end of concentrate tubing from the drain and place it in the solution tank. Plug in the unit. Allow the acid solution to circulate for 30 minutes. During recirculation, monitor the pH of the solution. If the pH rises above 3.0, add acid to reduce the pH to 2.0.



**CAUTION!** The temperature of the chemical solution will rise as it is recirculated. If the temperature exceeds 95°F, unplug the unit and allow the solution to cool to prevent damage to the RO elements.

**NOTE** A plastic gallon jug filled with ice may be placed in the solution to cool it.

14. When 30 minutes have passed, adjust the system pressure to the pressure recorded in Step 9. Measure the product flow rate, then compare this flow to the flow recorded in Step 9. If cleaning is successful a noticeably higher product flow should now be observed.
15. Disconnect power to the unit. If the cleaning was for removal of hardness scale or iron only, go to Step 23.
16. If the cleaning was for silt or bio-fouling, take a 250 ml sample of phosphoric acid solution and carefully add sodium hydroxide until the pH is at least 12. If the solution turns cloudy, it contains hardness and/or iron. Discard the contaminated acid and prepare a fresh 30 gallons of phosphoric acid solution. If the solution remains clear, then continue with Step 16.
17. Add sodium hydroxide to the phosphoric acid solution. The pH of the solution should be increased to 11.0-11.5.

**NOTE** The result is an alkaline solution of tri-sodium phosphate (TSP), a common ingredient in detergents.

18. Direct the concentrate tubing to drain, plug in the unit. Check that the unit is drawing chemical solution.



**CAUTION!** If the pump is noisy, cavitation is occurring and the pump will be damaged. Unplug the unit and check for any obstructions to flow. Reduce the pump pressure as required to prevent cavitation..

19. After approximately 5 gallons have been drawn from the solution tank, disconnect power to the unit.
20. Allow the elements to soak for 15 minutes. Plug in the unit. Draw another 5 gallons from the solution tank. Disconnect power to the unit. Remove the end of concentrate tubing from the drain and place it in the solution tank. Plug in the unit. Allow the alkaline solution to circulate for 30 minutes. During recirculation monitor the pH of the solution. If the pH drops below 10.0 add sodium hydroxide to increase the pH to 11.5.

**NOTE** If the caustic solution becomes dark brown (like coffee), it probably is saturated with organic material. Discard the solution and prepare a fresh batch of phosphoric acid and sodium hydroxide.

For more accurate testing, use a Hach Model DE-2 detergent test kit or equivalent to ensure that the product water is less than 0.05 ppm detergent.

A plastic gallon jug filled with ice may be placed in the solution tank to cool the solution.



**CAUTION!** The temperature of the chemical solution will rise as it is recirculated. If the temperature exceeds 95°F, unplug the unit and allow the solution to cool to prevent damage to the RO elements.

21. When 30 minutes have passed, adjust the system pressure to the pressure recorded in Step 9. Measure the product flow rate, then compare this flow to the flow recorded in Step 9. If cleaning is successful a noticeably higher product flow should now be observed.
22. Disconnect power to the unit. Remove the concentrate and product tubing from the solution tank and direct them both to drain. Plug in the unit to draw most of the remaining cleaning solution from the tank.



**CAUTION! Do not allow the unit to draw air from the tank, or the pump will be damaged.**

23. Disconnect power to the unit. Close the cleaning valve, reconnect the wires to the pressure switch, then open the feed water valve.
24. Connect power to the unit and flush the cleaning solution from the unit for 30 minutes or until the pH levels of the concentrate water and the product water remain constant.



**CAUTION! Soft water must be used to flush the caustic solution, or hardness will precipitate. If soft water is not available, use temporary portable exchange softener tanks.**

25. Adjust the system pressure to the normal value. Measure all flows, TDS levels, pressures, and temperature. Compare these values with the “new” and “now” values to determine if cleaning has been successful. If cleaning has not been successful, contact the dealer for suggestions on alternate cleaning chemicals. If cleaning has been successful, note which chemicals were effective. Use the same chemical(s) when the unit is cleaned again.
26. Replace the Pre-filter cartridge.
27. After cleaning and rinsing have been completed, connect the product tubing to the service line. Remove the jumper installed in Step 6 and reconnect the pressure switch. Rinse the cleaning tank and tubing with fresh water.



# RO Parts Diagrams and Lists

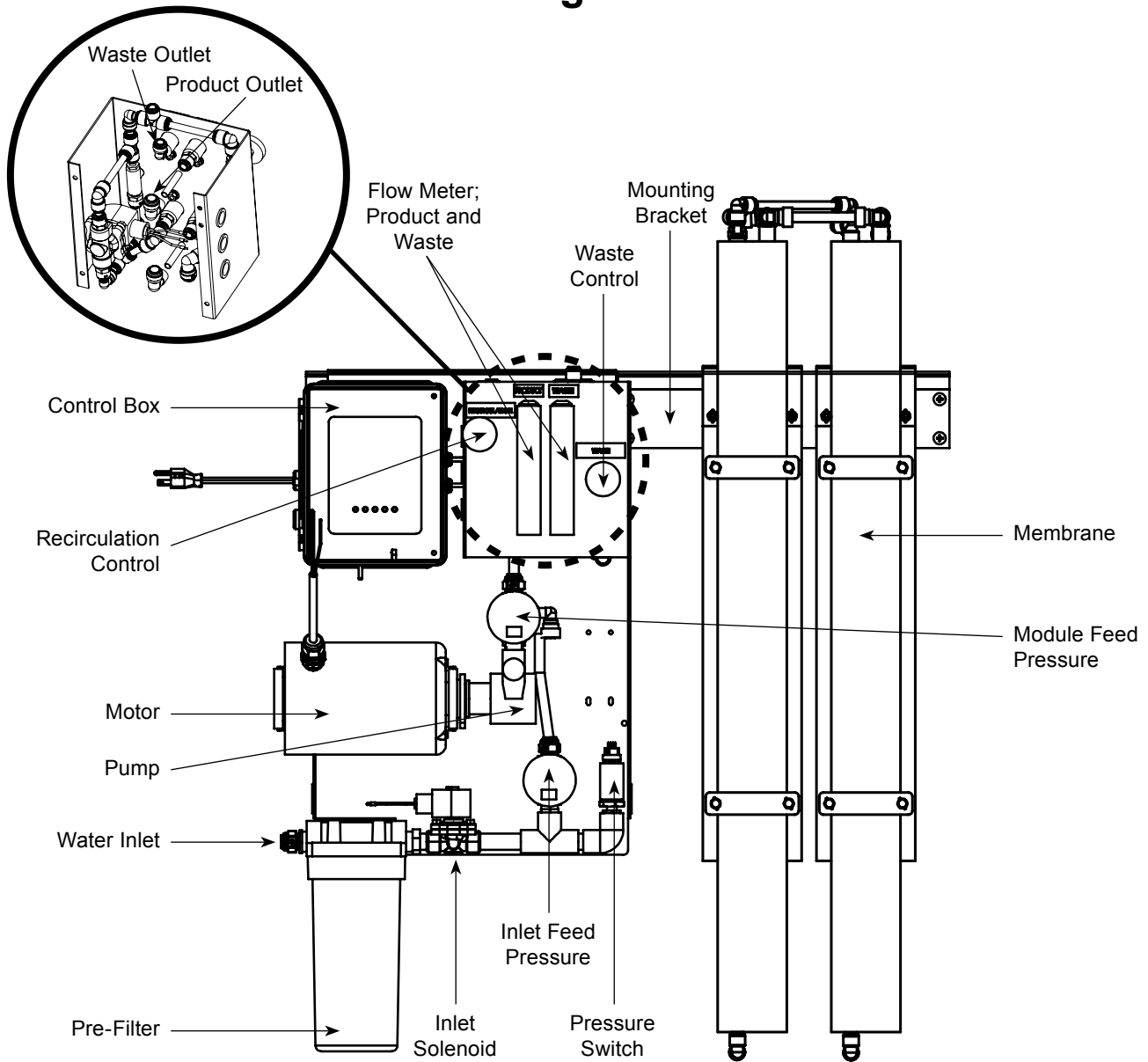

Part#	2675	2676	2677	2678	2679	2680	2681	2682	2683
Model #	T-250	T-500	T-750	T-1000	T-1200	T-1700	T-2200	T-2000F	T-4000F
Motor Panel Assembly, T-250,500,750,1000 P#95725	1	1	1	1	—	—	—	—	—
Motor Panel Assembly, T-1200,1700 P#95726	—	—	—	—	1	1	—	—	—
Motor Panel Assembly, T-2200 Part P#95727	—	—	—	—	—	—	1	—	—
Motor Panel Assembly, T-2000F, 4000F P#95728	—	—	—	—	—	—	—	1	1
Assembly, Membrane, 2.5"X21", Down P#95729	1	1	2	2	—	—	—	—	—
Assembly, Membrane, 2.5"X21", Up P#95730	—	1	1	2	—	—	—	—	—
Assembly Membrane, 2.5"X40",Down P#95731	—	—	—	—	1	2	2	—	—
Assembly Membrane, 2.5"X40",Up P#95732	—	—	—	—	1	1	2	—	—
Assembly, Membrane, 4"X40",Down P#95733	—	—	—	—	—	—	—	1	1
Assembly, Membrane, 4"X40",Up P#95734	—	—	—	—	—	—	—	—	1
Kit, Tube and Fittings, T-250, P#95735	1	—	—	—	—	—	—	—	—
Kit, tube and Fittings, T-500,1200, P#95736	—	1	—	—	1	—	—	—	—
Kit, Tube and Fittings, T-750,1700 P#95737	—	—	1	—	—	1	—	—	—
Kit, Tube and Fittings, T-1000, 2200, P#95738	—	—	—	1	—	—	1	—	—
Kit, Tube and Fittings, T-2000F P#95739	—	—	—	—	—	—	—	1	—
Kit, Tube and Fittings, T-4000F P#95740	—	—	—	—	—	—	—	—	1
Wall Mount Kit Extension, T-1000 P#95741	—	—	—	1	—	—	—	—	—

# Motor Panel Assembly - All Models

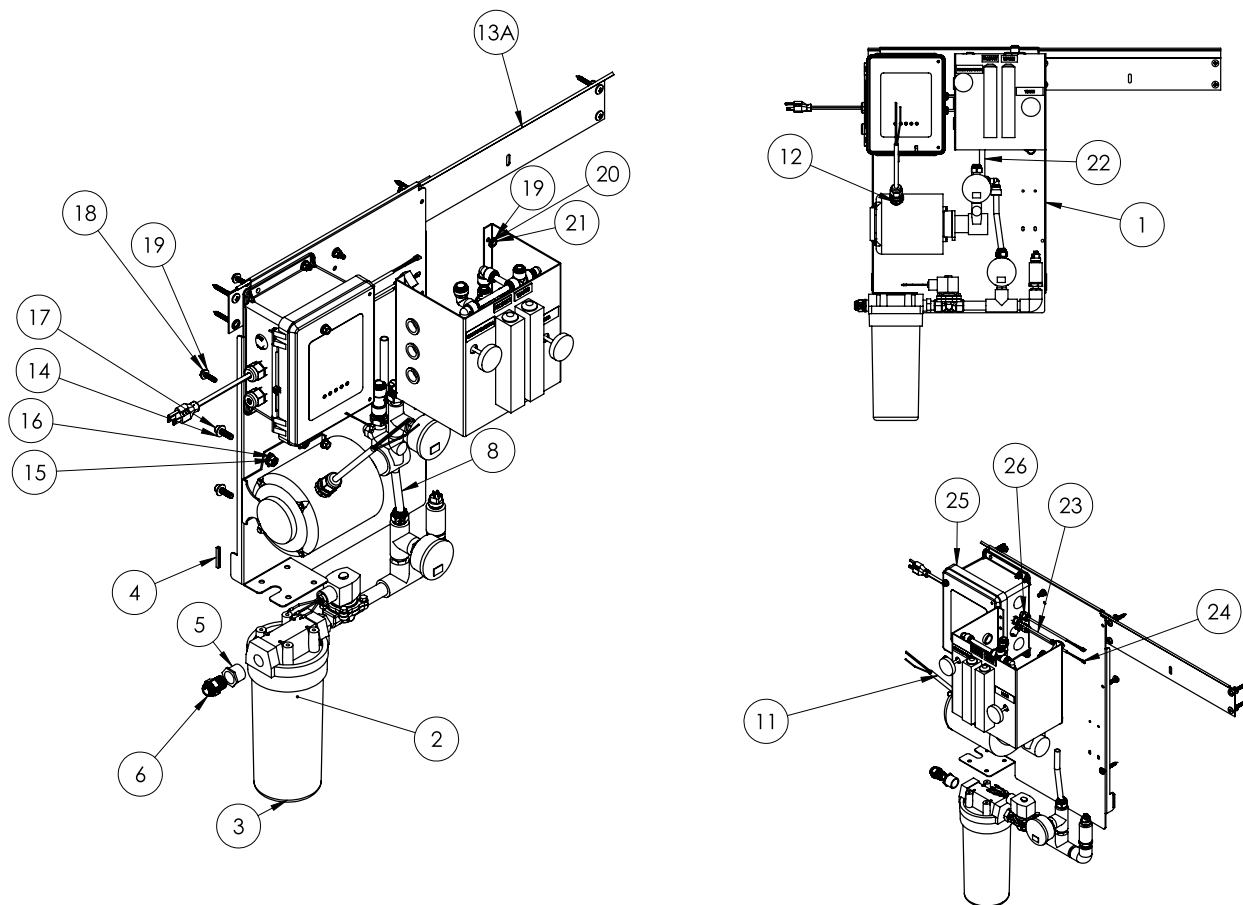

Figure 24. Motor Panel Assembly.

Item	Part #	Item Description	Qty
1	—	Panel, T Line RO	1
2	26273	Cartridge Filter	1
3	150067	Filter Housing, 10" BB	1
4	—	Trim, Edge, Length 1.5"	2
5	420735	Bushing, 3/4x1/2, TxT, PVC Sch.80	1
6	92712	Fitting, Male Connector, 1/2Tx1/2 NPTE, PI	1
8	115211	Tube, 1/2", Length 7.5"	1
11	92713	Power Cord, Motor, T Line	1
12	92714	Locknut, 1/2", Nylon	1
13A	92715	Wall Mount Kit, T series	1
13B	95741	Wall Mount Kit, T-1000, T-2200, Ext (not shown)	1
14	—	Washer, Flat, 5/16", 18-8SS	8
15	—	Nut, 5/16, HEX, 316SS	4
16	—	Washer, Lock, 5/16, 316SS	4

Item	Part #	Item Description	Qty
17	—	Screw, Cap, 5/16-18x1", 18-8SS, Hex Soc	4
18	—	Screw, Cap, 1/4-20x1,18-8SS, HEX HD	8
19	—	Washer, Flat, 1/4, 18-8SS	16
20	—	Washer, 1/4", Lock, Spring	8
21	—	Nut, 1/4-20, HEX, 18-8SS	8
22	115211	Tube, 1/2", Length 4.0"	1
23	92716	Cable, Pressure Tranducer, 39"L	1
24	92717	Cable, Solenoid, T	2
25	92718	Assembly, Controller, T Line	1
26	92719	Cord Grip, Liquid Tite, .181/.312 ID	2
27	101051	Pressure Gauge	2

## Feed Assembly - All Models

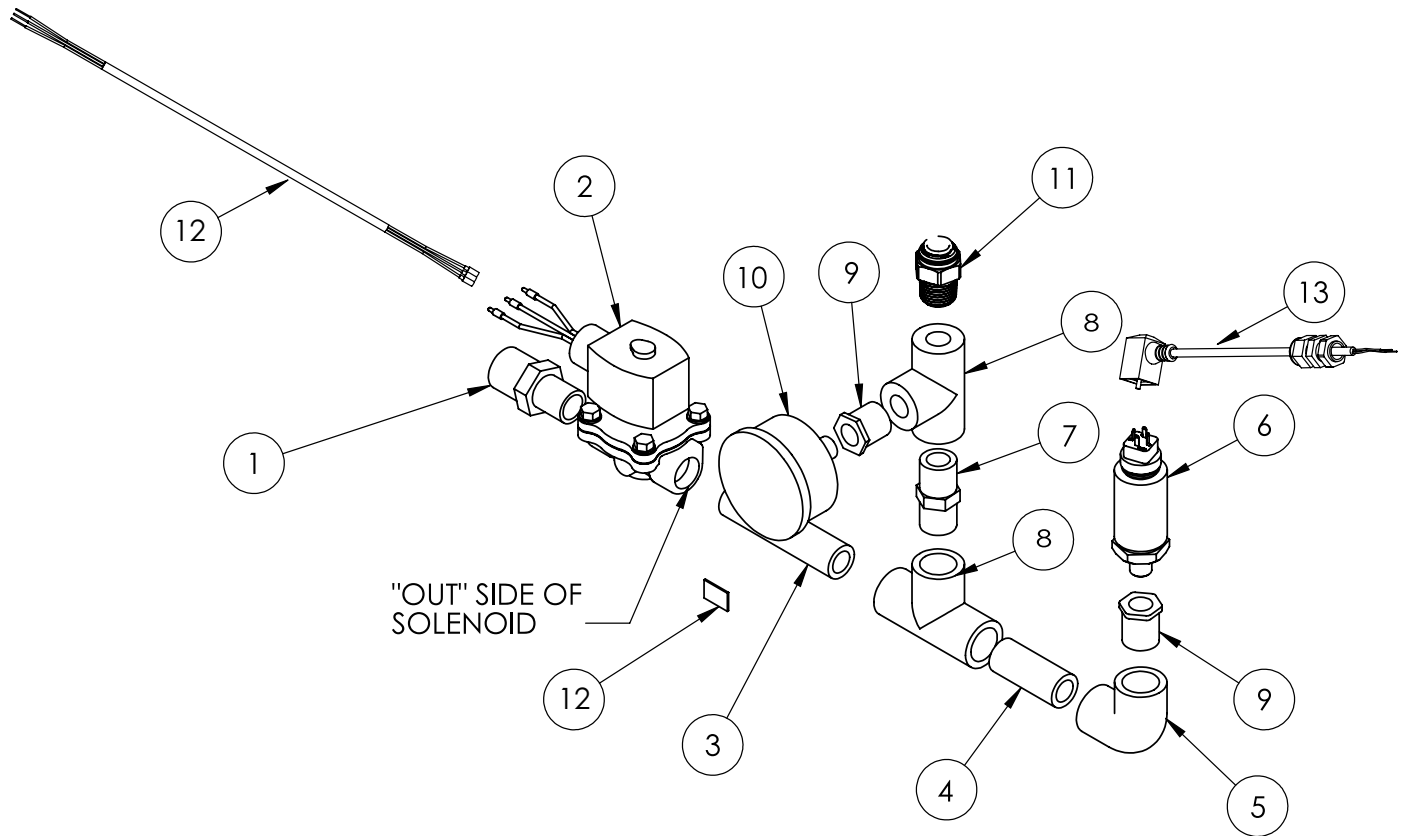

Figure 19. Feed Assembly.

Item	Part Number	Item Description	Quantity
1	92720	Nipple, Reducing, 3/4" MNPT X 1/2" MNPT, Sch.80, PVC	1
2	92721	Solenoid Valve, 1/2" NPT, 120V/60Hz	1
3	92722	Nipple, 1/2" x 3-1/2", PVC Sch.80	1
4	92723	Tee, 1/2", Socket, PVC Sch.80	1
5	92441	Nipple, 1/2 x 1-1/2", PVC Sch.80	1
6	92724	Elbow, 1/2" SOC, PVC Sch.80	1
7	420796	Bushing, 1/2" x 1/4", SXT, PVC Sch.80	1
8	92725	Pressure Switch, 6-30 PSI, ADJ	1
9	92759	Adapter, Male, 1/2" SPIGOT x NPT Sch.80	1
10	92443	Tee, 1/2" Threaded, PVC Sch.80	1
11	42079507	Bushing, 1/2" x 1/4", TXT, PVC Sch.80	1
12	101051	Pressure Gauge, 1/4" NPT, 0-200PSI	1
13	92726	Fitting, Male Connector, 1/2T x 1/2" NPT	1
14	92717	Cable, Solenoid	1
15	92716	Cable, Pressure, Transducer, 39"L	1

## Recirculation Assembly - All Models

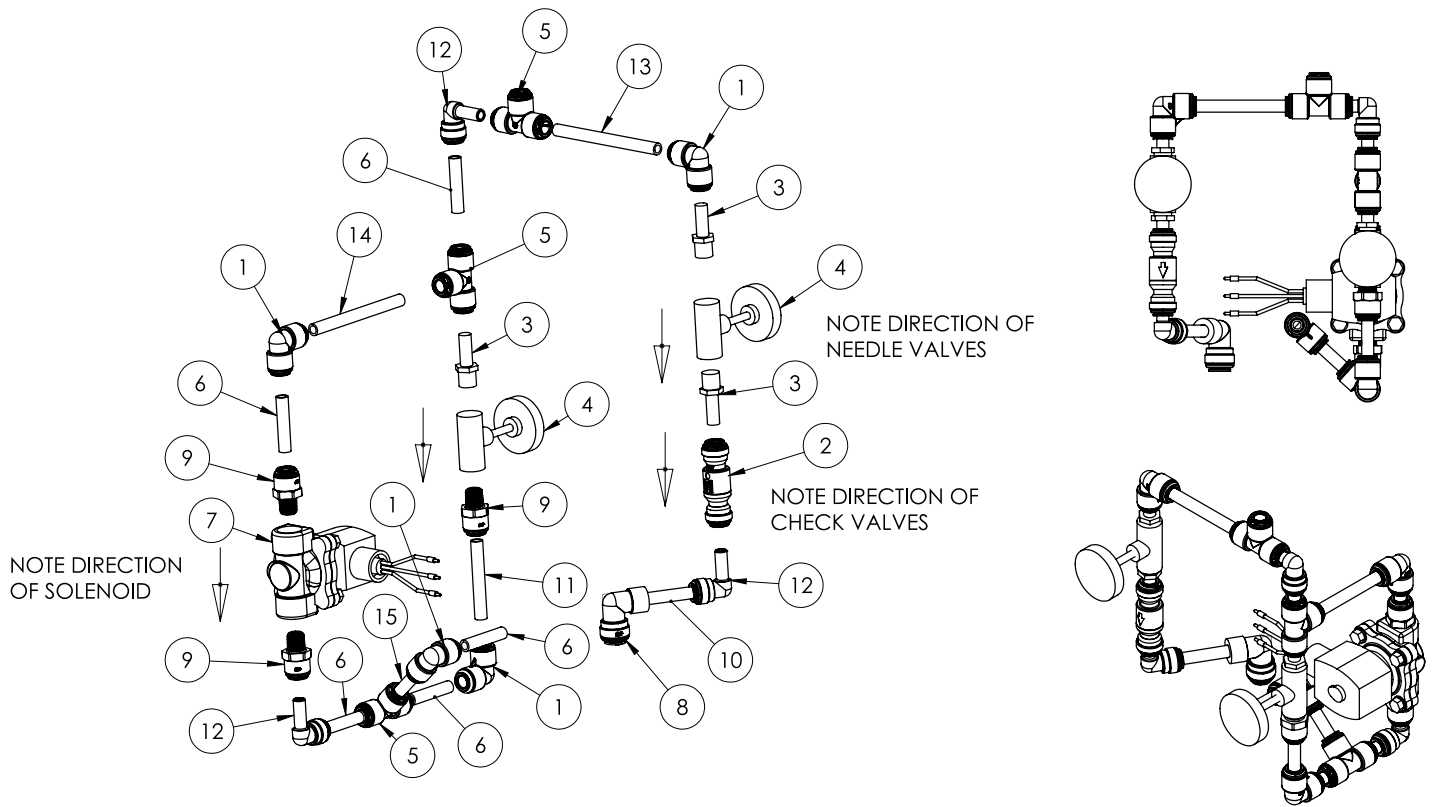

Figure 20. Recirculation Assembly.

Item	Part Number	Item Description	Quantity
1	92727	Fitting, Union Elbow, 3/8T, PI	4
2	3/8SCV	Valve, Check, 3/8, PI	1
3	92728	Fitting, Stem Adapter, 1/4 NPT x 3/8 Stem, PI	3
4	303177	Needle Valve, 1/4" FNPT, Brass	2
5	92729	Fitting, Union Tee, 3/8T, PI	3
7	92721	Solenoid Valve, 1/2" NPT, 120V/60Hz	1
8	92730	Fitting, Union, 1/2T x 3/8T, PI	1
9	92731	Fitting, Male Adapter, 3/8T x 1/2NPTE, PI	3
12	92732	Fitting, Stem Elbow, 3/8T x 3/8 Stem, PI	3
6, 10, 11, 13, 14, 15	115212	Tube, 3/8"	

## Motor / Pump Assembly

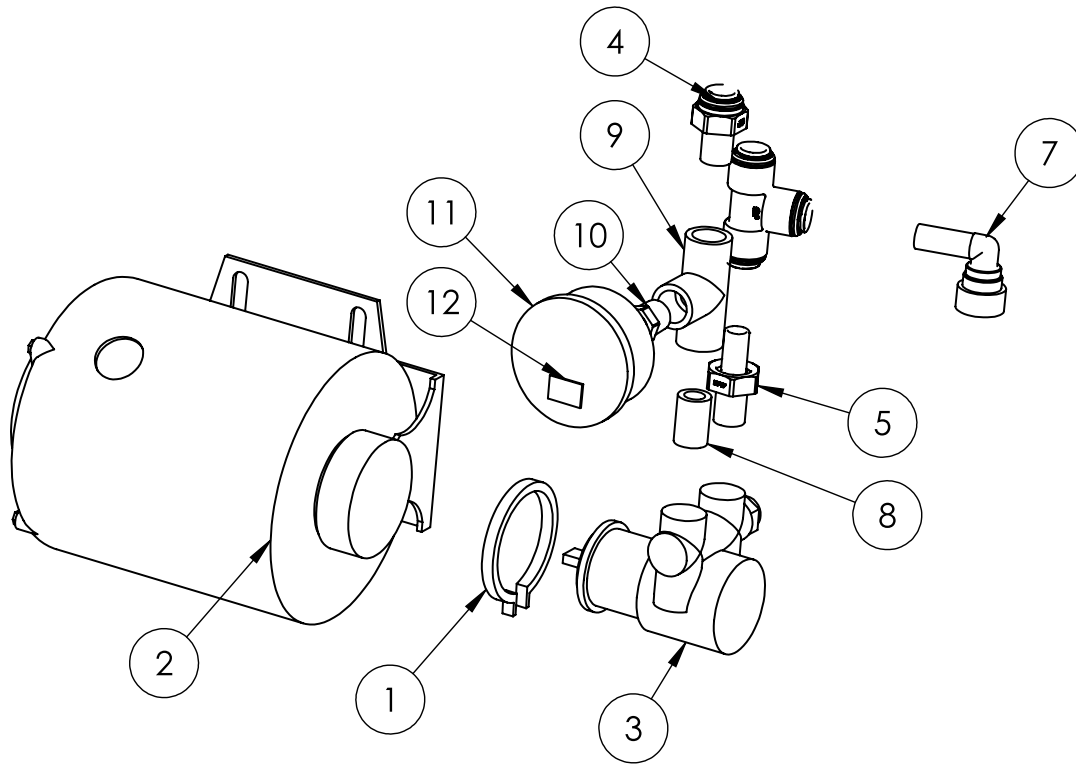

Figure 21. Motor / Pump Assembly.

Item	Part Number	Item Description	Quantity
1	74914	V-Band, Pump/Motor	1
2	100786	Motor, for T-250, 500, 750, 1000;	1
	100788	Motor, for T-1200, 1700, 2200, T-2000F, 4000F	
3	74907	Pump, Rotary Vane, Brass for T-250, 500, 750, 1000;	1
	92740	Pump, Rotary Vane, Brass for T-1200, 1700;	
	92741	Pump, Rotary Vane, Brass for T-2200;	
	92742	Pump, Rotary Vane, Brass for T-2000F, 4000F	
4	92733	Fitting, Male Adapter, 1/2T x 3/8 NPTE, PI	1
5	92734	Fitting, Stem Adapter, 3/8 NPTE x 1/2 Stem, PI	1
	92735	Fitting, Union Tee, 1/2T, PI	1
7	92736	Fitting, Stem Elbow, 1/2T x 1/2 Stem, PI	1
8	92737	Nipple, 3/8 x Close, PVC Sch.80, TBE	1
9	92738	Tee, 3/8", Threaded, PVC Sch.80	1
10	92739	Bushing, 3/8 x 1/4, TxT, PVC Sch.80	1
11	101051	Pressure Gauge, 1/4" NPT, 0-200 PSI, Liquid filled	1

# Membrane Vessel

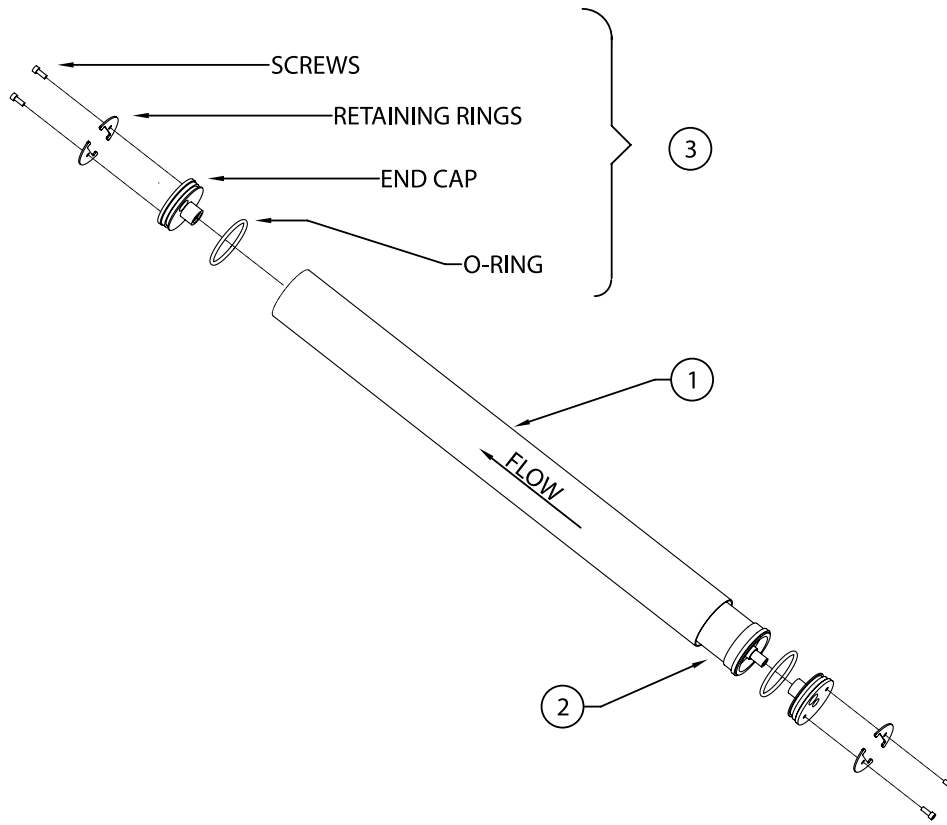

Figure 22. Membrane vessel.

Item	Description	Part #	T-250	T-500	T-750	T-1000	T-1200	T-1700	T-2200	T-2000F	T-4000F
1	Assembly, Membrane and Housing, Down (2.5" x 21") (1) DOWN	95729	1	1	2	2					
	Assembly, Membrane and Housing, (2.5" x 21") (1) UP	95730		1	1	2					
	Assembly Membrane and Housing, (2.5" x 40") (1) DOWN	95731					1	2	2		
	Assembly Membrane and Housing, (2.5" x 40") (1) UP	95732					1	1	2		
	Assembly, Membrane and Housing, (4" x 40") (1) DOWN	95733								1	1
	Assembly, Membrane and Housing, (4" x 40") (1) UP	95734									1
2	Membrane Only, 2.5" x 21"	92042									
	Membrane Only, 2.5" x 21"	92038									
	Membrane Only, 4" x 40"	92036									
3	End Plug Assembly, 2.5"	92743	2	4	6	8	4	6	8		
	End Plug Assembly, 4"	92744								2	4

# Flow Meter Sub-Assembly

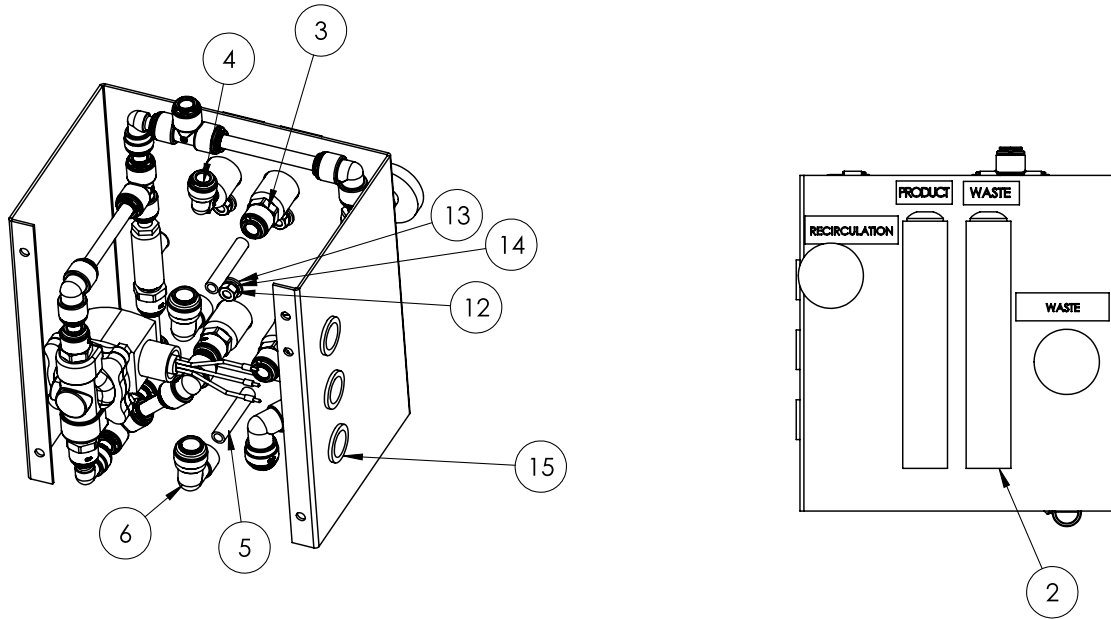

Figure 23. Flow meter housing and connections.

Item	Part Number	Item Description	Quantity
2	92745	Flow meter, .1-1 GPM, Panel Mount for T-250, 500, 750, 1000	2
	92750	Flow meter, .35-3.5 GPM, Panel Mount for T-1200, 1700, 2200, 2000F, 4000F	
3	92746	Fitting, Male Adapter, 3/8Tx1/4NPTE, PI	3
4	92747	Fitting, Union Elbow, 1/4Tx3/8T, PI	1
5	115212	Tube, 3/8"	2
6	92748	Fitting, Union, 1/2Tx3/8T, PI	2
12	—	Nut, 1/4-20, HEX, 18-8SS	
13	—	Washer, Flat, 1/4, 18-8SS	
14	—	Washer, 1/4", Lock, Spring	
15	92749	Bushing, Panel	3

# T-250 Sub-Assembly

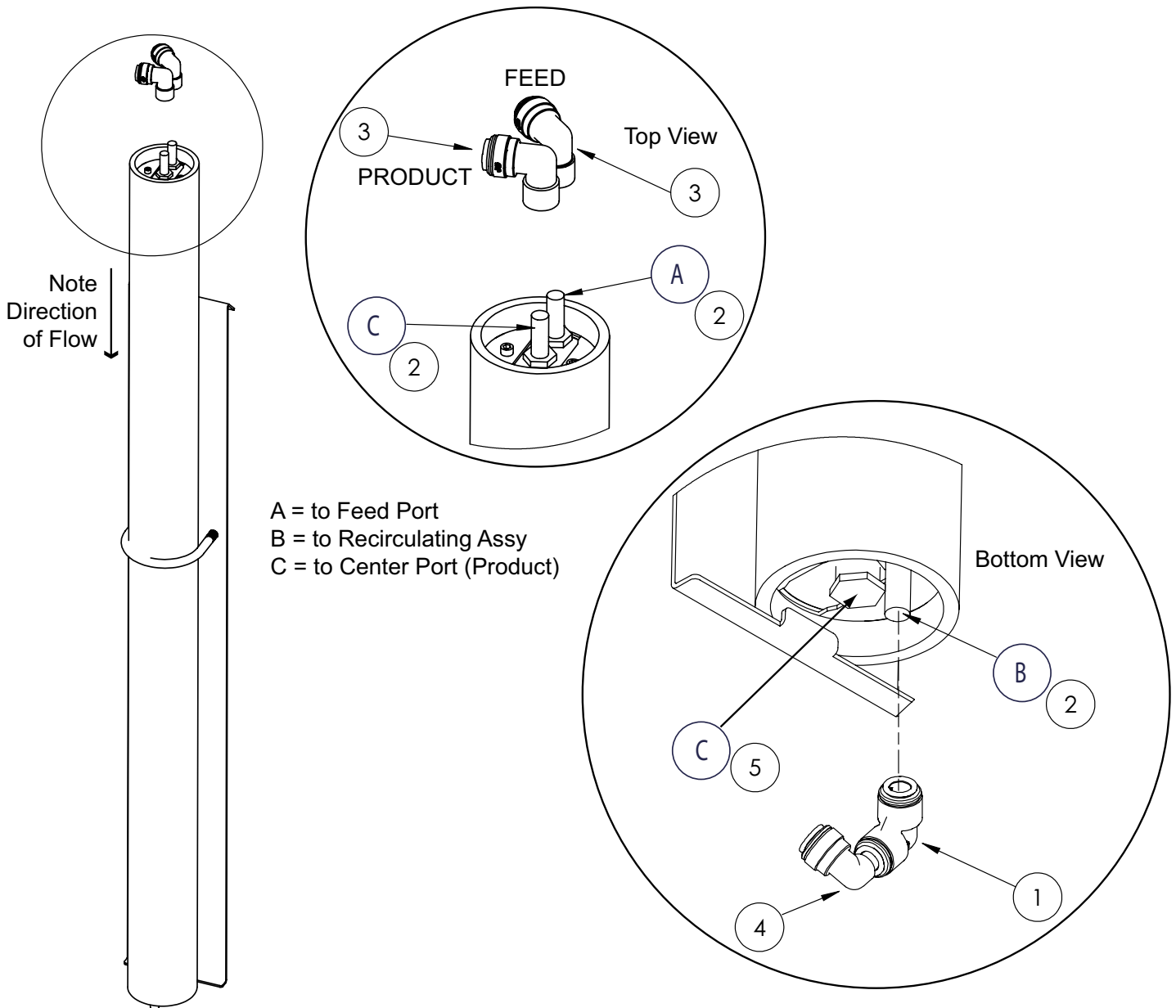

Figure 25. T-250 sub-assembly.

Item	Part Number	Item Description	Quantity
	92729	Assembly, Membrane Housing, Single, 2.5"x21"	1
	95735	Kit, Tube and Fittings, T-250 (includes items 1–5)	
1	92727	Elbow, Union, 3/8 Tube, PI, Polypropylene	1
2	92728	Stem Adapter, 1/4Tx3/8 Stem, Polypropylene	3
3	92730	Elbow, Union, Reducing, 1/2 x 3/8, PI, Polypropylene	2
4	92732	Elbow, Plug In, 3/8" stem, 3/8 tube	1
5	92760	Plug, 1/4" NPT, PVC Sch.80	1



# T-500, T-1200 Sub-Assembly

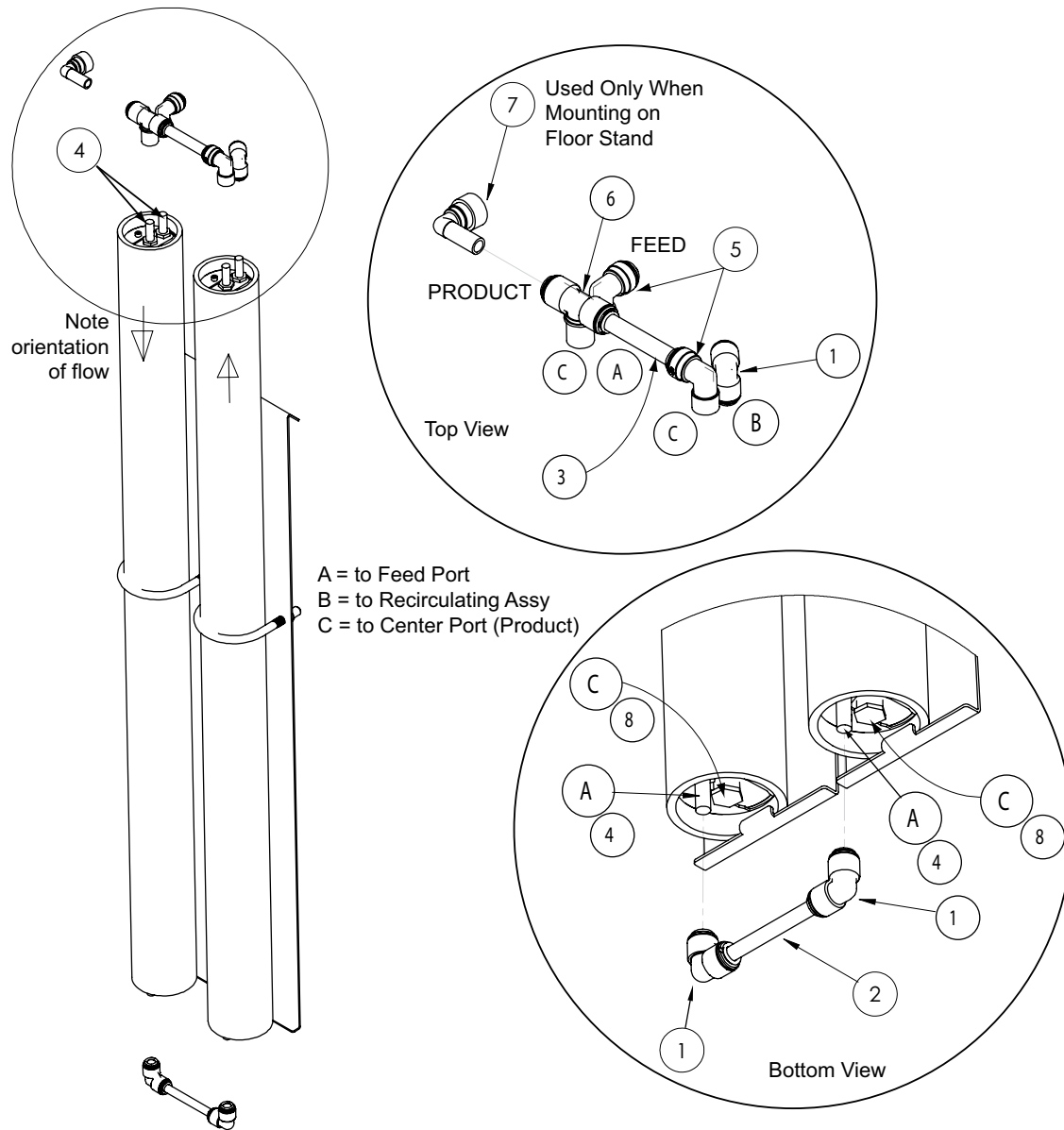

Figure 26. T-500, T-1200 sub-assembly.

Item	Part Number	Item Description	Quantity
	95729 (DOWN) 95730 (UP)	Assembly, Membrane Housing, Single, 2.5"x21" (T-500)	2
	95731 (DOWN) 95732 (UP)	Assembly, Membrane Housing, Single, 2.5"x40" (T-1200)	2
	95736	Kit, Tube and Fittings, T-500, T-1200 (includes items 1–8)	
1	92727	Elbow, Union, 3/8 Tube, PI, Polypropylene	3
2	115212	Tube, 3/8", Cut Length 3"	1
3	115211	Tube, 1/2", Length 3.5"	1
4	92728	Stem Adapter, 1/4Tx3/8 Stem, Polypropylene	6
5	92730	Elbow, Union, Reducing, 1/2 x 3/8, PI, Polypropylene	2
6	92751	Tee, Union, Reducing, 1/2 Ends, 3/8 Branch, PI, Polypropylene	1
7	92736	Elbow, 1/2 Stem x 1/2T, PI	1
8	92760	Plug, 1/4" NPT, PVC Sch.80	2

# T-750, T-1700 Sub-Assembly

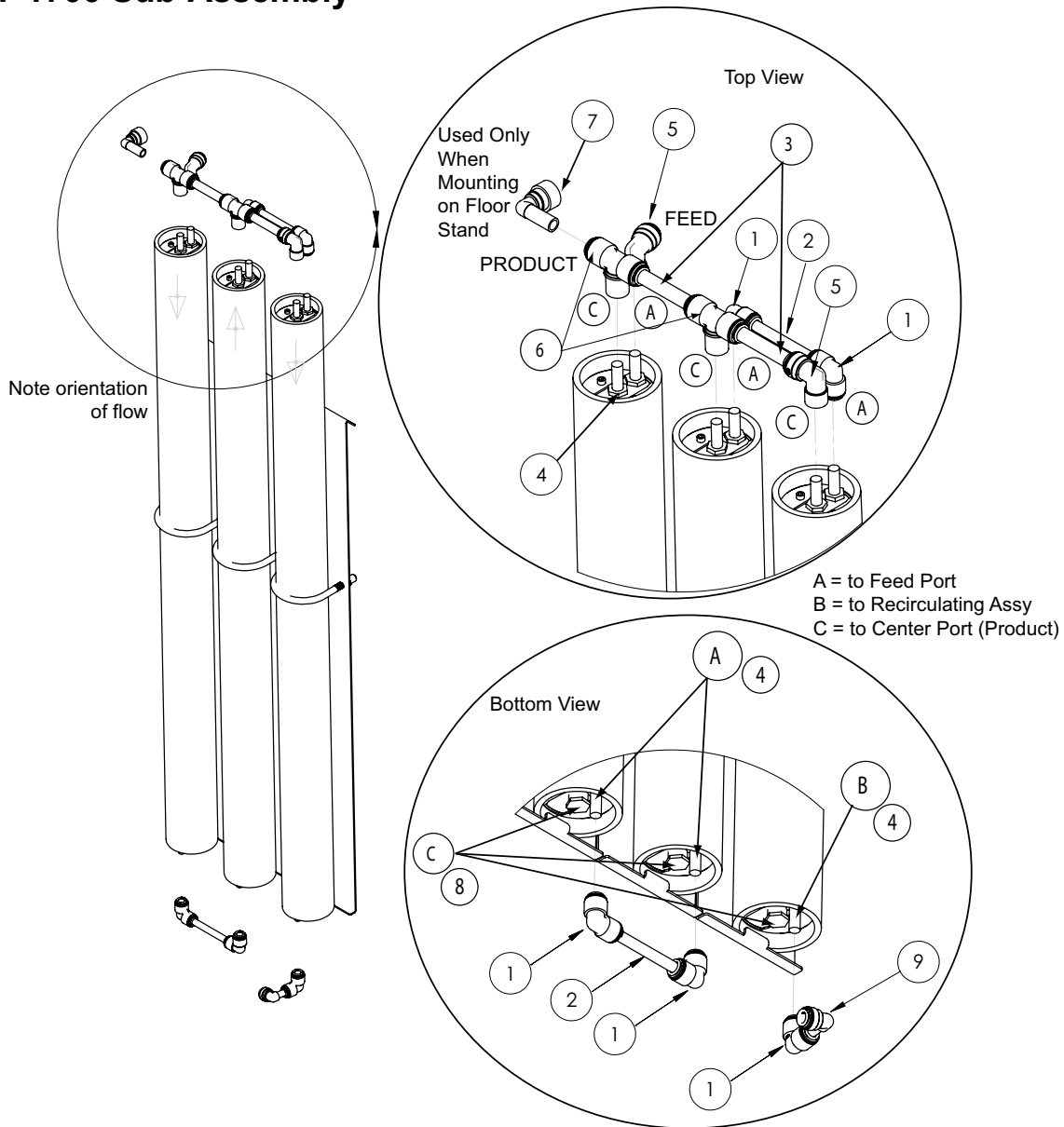

Figure 27. T-750, T-1700 sub-assembly.

Item	Part Number	Item Description	Quantity
	95729 (DOWN) - 2 95730 (UP) - 1	Assembly, Membrane Housing, Single, 2.5"x21", T-750	
	95731 (DOWN) - 2 95732 (UP) - 1	Assembly, Membrane Housing, Single, 2.5"x40", T-1700	
	95737	Kit, Tube and Fittings, T-750, T-1700 (includes items 1–9)	
1	92727	Elbow, Union, 3/8 Tube, PI, Polypropylene	5
2	115212	Tube, 3/8", cut length 4.4"	2
3	115211	Tube, 1/2", Length 4.25"	2
4	92728	Stem Adapter, 1/4Tx3/8 Stem, Polypropylene	9
5	92730	Fitting, Union, Reducing, 1/2 x 3/8, PI, Polypropylene	2
6	92751	Tee, Union, Reducing, 1/2 Ends, 3/8 Branch, PI, Polypropylene	2
7	92736	Elbow, 1/2 Stem x 1/2T, PI	1
8	92760	Plug, 1/4" Thd, PVC	3
9	92732	Elbow, 3/8" Stem, 3/8 tube	1

# T-1000, T-2200 Sub-Assembly

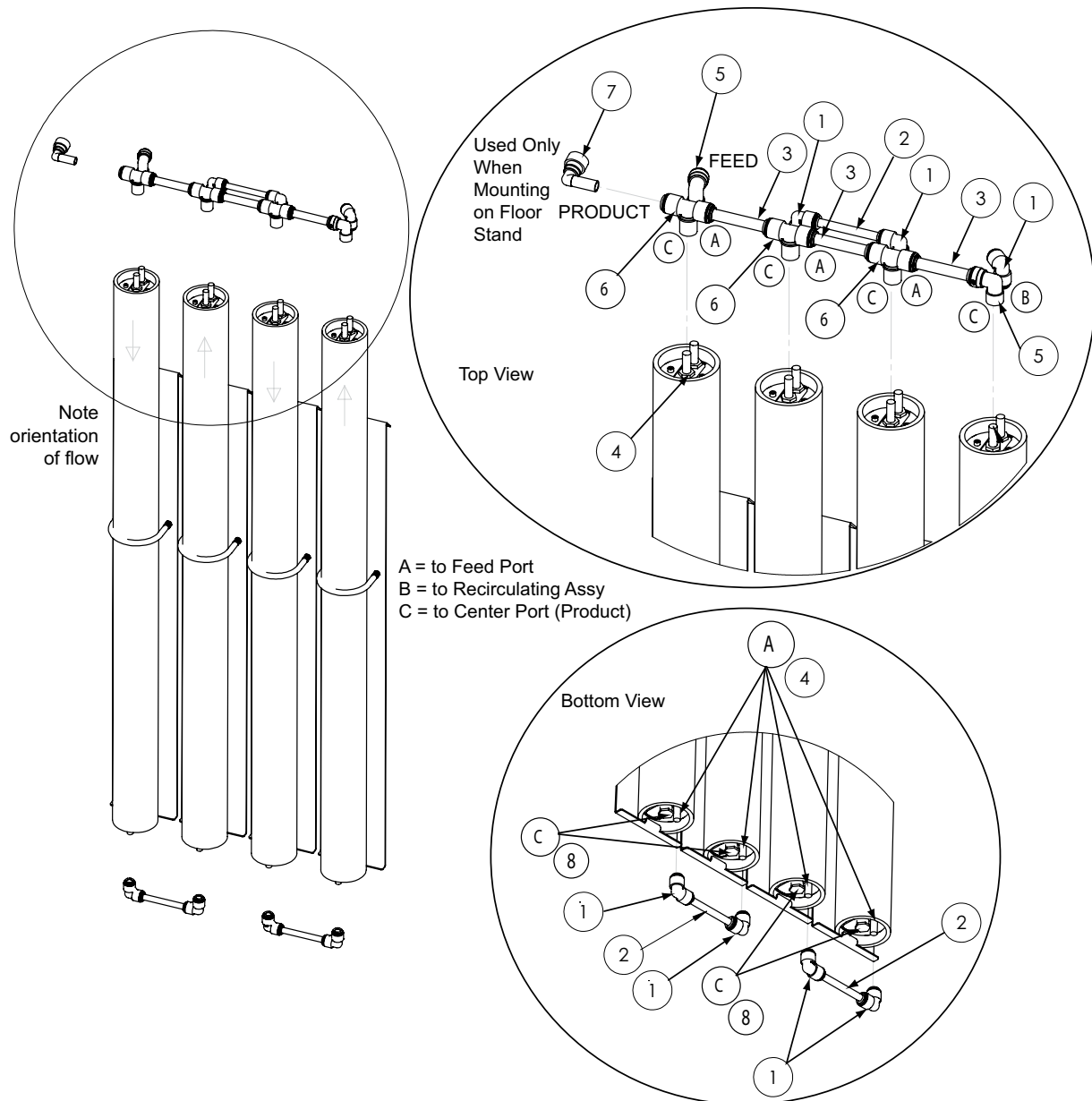

Figure 28. T-1000, T-2200 sub-assembly.

Item	Part Number	Item Description	Quantity
	95738	Kit, Tube and Fittings, T-1000, T-2200 (includes items 1–8)	
	95729 (DOWN) - 2 95730 (UP) - 1	Assembly, Membrane Housing, Single, 2.5"x21", T-1000	
	95731 (DOWN) - 2 95732 (UP) - 2	Assembly, Membrane Housing, Single, 2.5"x40", T-2200	
1	92727	Elbow, Union, 3/8 Tube, PI, Polypropylene	7
2	115212	Tube, 3/8", cut length 4.4"	3
3	115211	Tube, 1/2", Length 4.25"	3
4	92728	Stem Adapter, 1/4Tx3/8 Stem, Polypropylene	12
5	92730	Elbow, Union, Reducing, 1/2 x 3/8, PI, Polypropylene	2
6	92751	Tee, Union, Reducing, 1/2 Ends, 3/8 Branch, PI, Polypropylene	3
7	92736	Elbow, 1/2 Stem x 1/2T, PI	1
8	92760	Plug, 1/4" Threaded PVC	4

# T-2000F Sub-Assembly

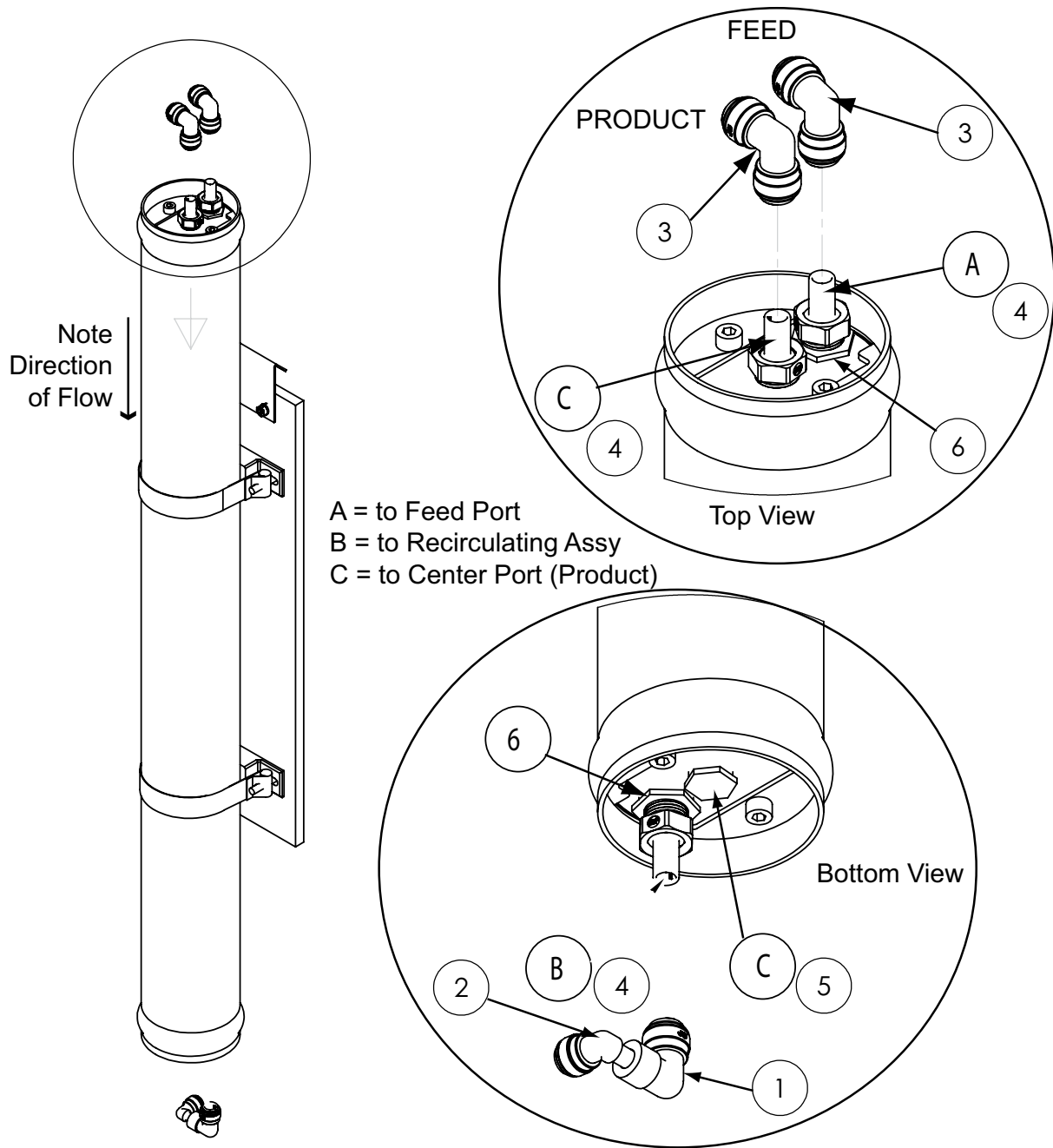

Figure 29. T-2000F sub-assembly.

Item	Part Number	Item Description	Quantity
	95733 (DOWN) - 1	Assembly, Membrane Housing, Single, 4.0"x40"	
	95739	Kit, Tube and Fittings, T-2000F (includes items 1-7)	
1	92730	Elbow, Union, Reducing, 1/2 x 3/8, PI, Polypropylene	1
2	92732	Elbow, Plug In, 3/8" stem, 3/8 tube	1
3	92752	Elbow, Union, 1/2 Tube, Polypropylene	2
4	92761	Stem Adapter, 1/2Tx1/2 Stem, Polypropylene	3
5	92762	Plug, 1/2" NPT, PVC Sch.80	1
6	92763	Bushing, 3/4x1/2, TxT, PVC Sch.80	2
7	—	Carton, Tubing and Fittings Kit	1

# T-4000F Sub-Assembly

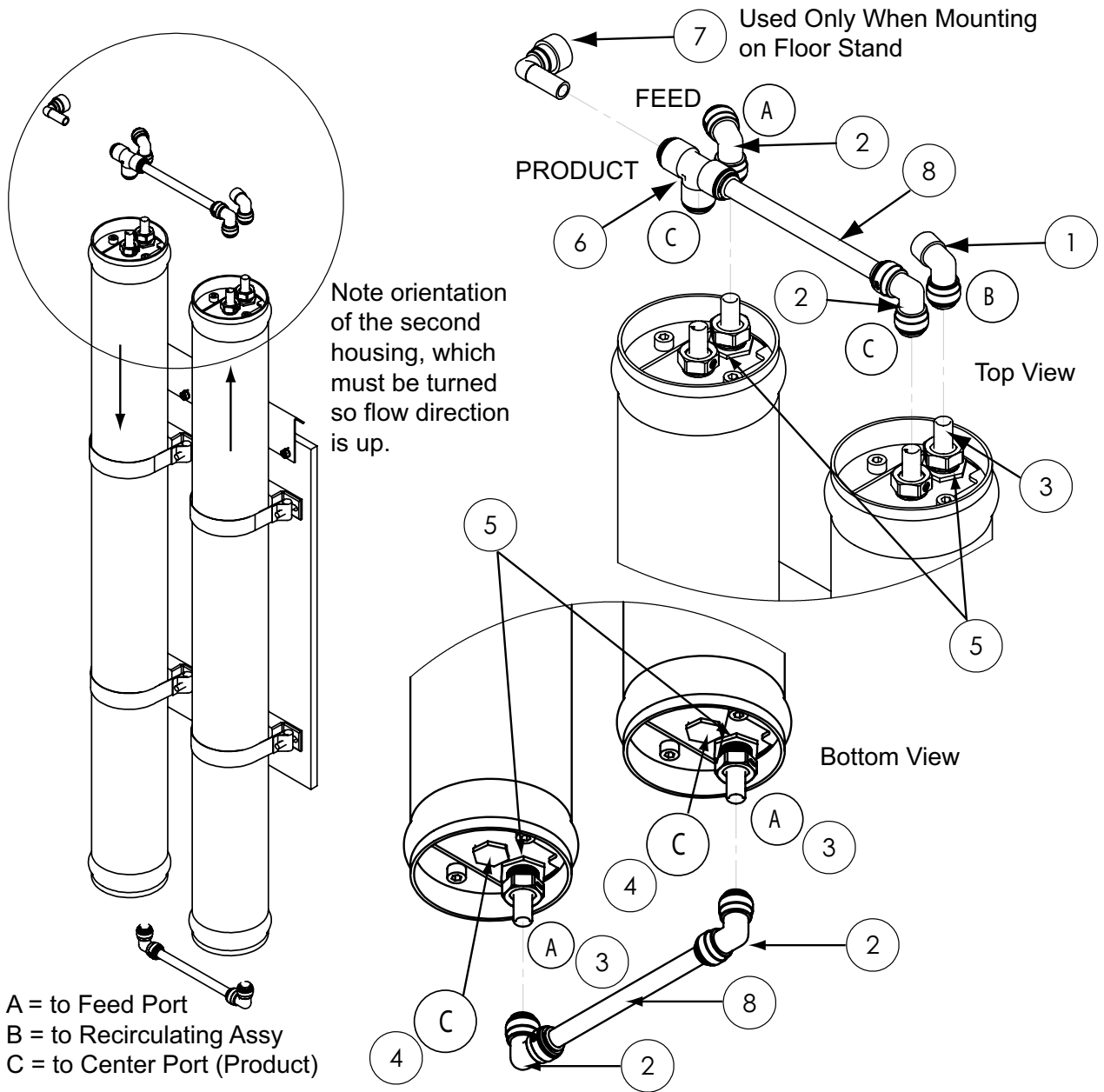

Figure 30. T-4000F sub-assembly.

Item	Part Number	Item Description	Quantity
	92733 (DOWN) - 1 95734 (UP) - 1	Assembly, Membrane Housing, Single, 4.0"x40"	
	95740	Kit, Tube and Fittings, T-4000F (includes items 1-8)	
1	92748	Elbow, Union, Reducing, 1/2 x 3/8, PI, Polypropylene	1
2	92752	Elbow, Union, 1/2 Tube, Polypropylene	4
3	92761	Stem Adapter, 1/2Tx1/2 Stem, Polypropylene	6
4	92762	Plug, 1/2" NPT, PVC Sch.80	2
5	92763	BUSHING,3/4x1/2,TxT,PVC Sch.80,	4
6	92785	Tee, Union, 1/2 Tube, PI, Polypropylene	1
7	92736	Elbow,1/2 Stem x 1/2T,PI	1
8	115211	Tube, 1/2", Length 7.5"	2

# T Controller Assembly

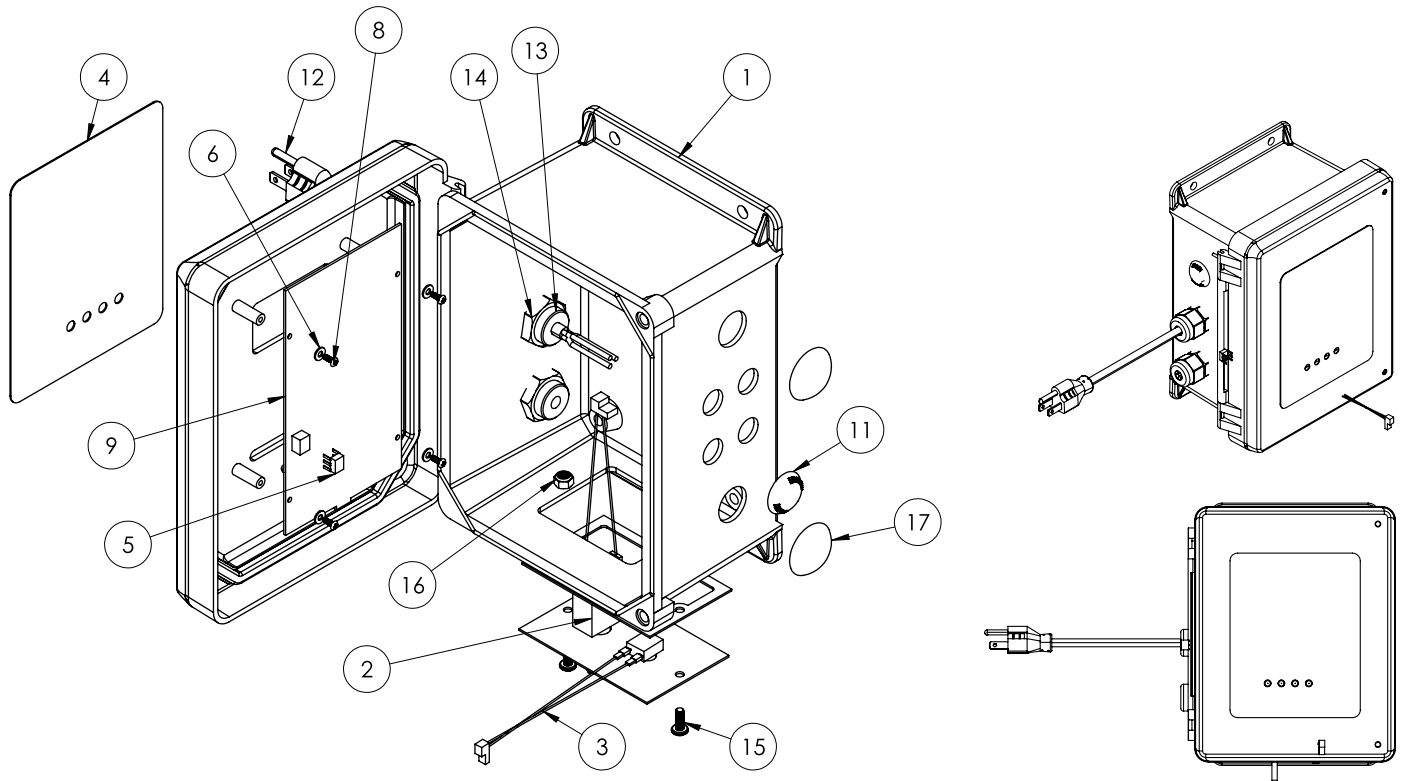

Figure 31. T controller assembly.

Item	Part Number	Item Description	Quantity
	92753	Complete Controller Assembly	
1	—	Enclosure	1
2	92754	Assembly, Cable, Rocker Switch	1
3	92755	Assembly, Cable, Push Button	1
5	92756	Switch, Dip, 3 position	1
6	—	Washer, Flat, .14", Nylon	4
7	—	Cover Plate	1
8	—	Screw, 4-24 PH Phillips, 18-8 SS Type B, 5/16" Length	4
9	92757	Circuit Board	1
10	—	Gasket, Pilot Valve	1
11	—	Plug, Dome, .625 Hole	2
12	92758	Power Cord	1
13	—	Cord Grip, Liquid Tight, .170/.450 ID	2
14	—	Locknut, 1/2", Nylon	2
15	—	Screw, MACH, 10-32x1/2, 18-8SS, Pan HD PHIL	2
16	—	Nut, #10-32 w/Nylon Insert	2
17	—	Plug, Dome, .875 Hole	2