



SCALELESS

Scaleless POE Residential Systems

SL844-12, SL948-16, SL1054-20, SL1252-30

Chemical Free, Salt Free Scale Prevention

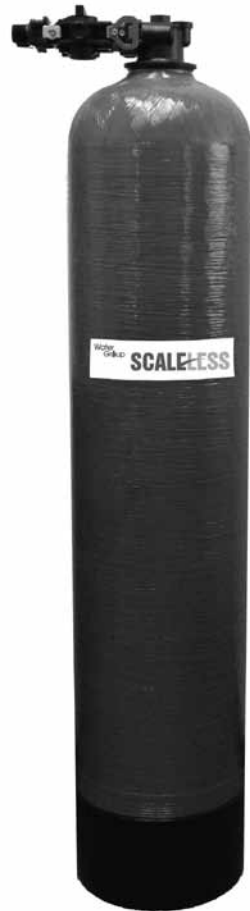

This manual contains important maintenance procedures for the continued proper operation of your unit. These **MUST** be performed regularly for your guarantee to remain valid.

Introduction

The Scaleless system provides protection from scale formation throughout the home. The Scaleless system can be installed at the point of entry to treat your entire home, both hot and cold water, or it can be located directly before a water heater or other device (e.g. sauna, etc) that requires protection from hard water.

Scaleless reduces or eliminates scale formation on internal and external plumbing surfaces as well as reducing spotting and streaking normally associated with hard water.

Scaleless prevents scale by transforming the normal dissolved hardness minerals into undissolved crystal micro-particles. These crystals stay suspended in the water and have a greatly reduced ability to react and attach to surfaces like dissolved hardness does. Therefore the problem of internal buildup of scale in pipes, water heaters and on fixtures and glass is greatly reduced.

Scaleless is not a water softener – Low or phosphate-free cleaning products are recommended to achieve optimum results. Modern surfactant or detergent based, liquid soaps are preferred over old-fashioned caustic solid soaps.

Unlike softened water, Scaleless treated water maintains the beneficial essential mineral content of your water and is safe to drink.

Scaleless Benefits.

- Chemical Free Scale Prevention. Cost savings and environmental benefits.
- Virtually Maintenance Free. No salt bags or other chemicals to buy, transport and store.
- No Electricity, no wastewater, completely self-contained.
- Beneficial minerals retained for more healthful drinking water.
- Improves the efficiency of water-using appliances.
- Simple installation – no electrical and drain hookup
- Safe for landscaping and lawn watering. No need to costly bypass plumbing
- Compatible with all on-site and community wastewater treatment systems
- Not subject to water softener restrictions and “bans”

System Overview



Tank Head Part # 61445-1

Frequency of Replacement of Media Bed is 3 Years

Replacement Media Bed Part # are as follow

Media Replacement	Part #
SL844-12	21514-5
SL948-16	21514-6
SL1054-20	21514-8
SL1252-30	1514-11

Equipment Specifications

Scaleless systems are complete, self-contained, loaded with media and ready to use. A simple inlet and outlet connection is all that is required for installation. Please review operating pressures, temperatures and water chemistry limitations to ensure compatibility.

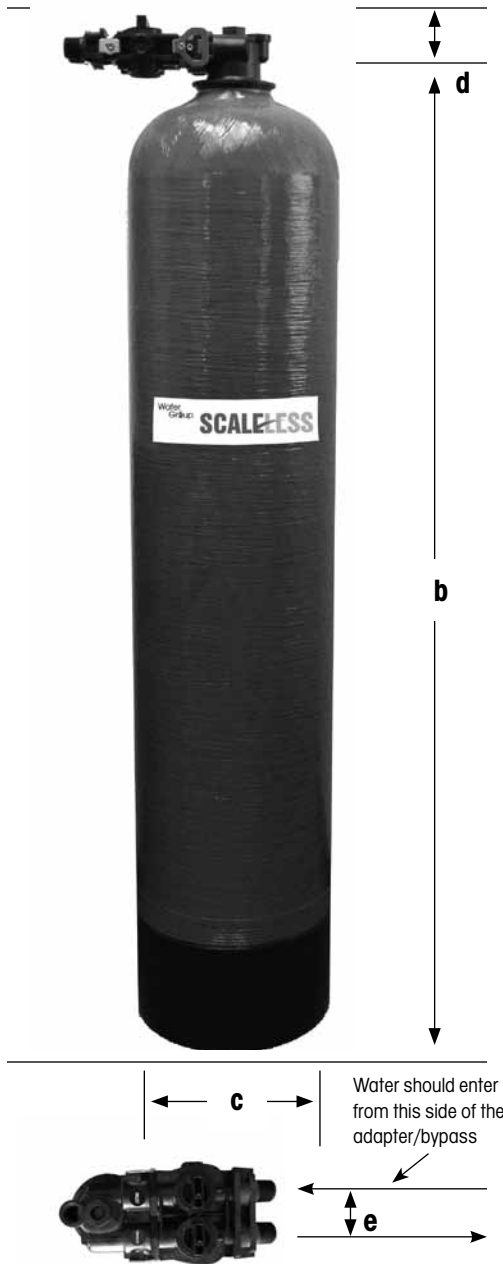

Conditions for Use

Inlet/Outlet Connection	3/4" - 1"
Temperature	40° - 110°F
pH	6.5 to 8.5
Ferrous Iron, Max*	0.3 mg/L
Manganese, Max*	0.05 mg/L
Copper, Max*	1.3 mg/L
Water Pressure	15 min., 100 max (PSI)

* See note about Iron, Manganese and Copper on the next page.

Dimensions (nominal - inches) -

SL844-12, SL948-16, SL1054-20 and SL1252-30

a	48.5	52.5	59.5	56.5
b	46	48	57	54
c	8	9	10	12
d	2.5	2.5	2.5	2.5
e	3.0	3.0	3.0	3.0

Using Scaleless with other water treatment equipment.

Due to the unique properties of Scaleless, there are some unique requirements for using Scaleless in conjunction with filtration or other forms of water treatment.

1. Scaleless must be the last stage in the treatment chain. Do not install any filters after Scaleless or before any devices for which scale prevention is required. POU filters, e.g. carbon or RO are exempt from this requirement.
2. Do not apply phosphate or any other antiscalant either before or after Scaleless.

Item #	Model #	Tank	Media (lbs)	Max Flow Rate (GPM)	Frequency of Media Replacement	Connections I/O	Bypass	Replacement Media Bed #	Dry Weight (lbs)	Service Weight (lbs)
7951	SL844-12	8 x 44	5	12	3 years	3/4"	Plastic	21514-5	25	97
7952	SL948-16	9 x 48	6	16	3 years	3/4"	Plastic	21514-6	29	129
7953	SL1054-20	10 x 54	8	20	3 years	1"	Plastic	21514-8	35	168
7954	SL1252-30	12 x 52	11	30	3 years	1"	Plastic	21514-11	43	235

An important note about iron, manganese and copper in the water supply.

Iron and Manganese

Just as with conventional water softening media, Scaleless needs to be protected from excess levels of certain metals that can easily coat the active surface, reducing its effectiveness over time. Public water supplies rarely, if ever, present a problem, but if the water supply is from a private well confirm that the levels of iron (Fe) and manganese (Mn) are less than 0.3 mg/L and 0.05 mg/L respectively. Copper should be less than 1.3 mg/L.

Copper

Copper usually originates from new copper plumbing upstream of the Scaleless system. If this condition exists, we recommend waiting 3-4 weeks before placing the system in operation. This will allow the copper surfaces to be fully flushed and develop a natural protective surface. To further minimize any problem with excess copper the plumbers should be advised to avoid applying excess flux on the inner surfaces of the pipe and to use a low-corrosivity water soluble flux listed under the ASTM B813 standard. Once the plumbing connections are complete, place the Scaleless system in bypass prior to following the startup procedure and flush the plumbing for at least 10 minutes.

Cautions!

- Do not let the system freeze. Damage to the tank may result.
- System must be operated in a vertical position. Do not lay it down during operation. The system may be placed in any position for shipping and installation but must be operated in the vertical position.
- Place the system on a smooth, level surface. Because the system operates in an UP-Flow, fluidized bed mode, having a level surface is more important than with a softener or media filter.
- A bypass valve should be installed on every system to facilitate installation and service.
- Observe all local plumbing and building codes when installing the system.

Notes to the Installer.

The Scaleless system differs from a conventional softener or media filter in a number of key respects.

- The system is light and only partially filled with media. This is normal. The UP-flow operation of the system requires a lot of freeboard to allow the bed to fully fluidize.
- The system has no underbed so you can tip the system over without any fear of upsetting the media. This makes transportation and installation much easier than conventional systems.
- Because the Scaleless system operates in the UP-Flow mode, the tank connections are opposite of what you're used to.
- Please see the "important note about iron, manganese and copper" above.
- Please see the note about "Using Scaleless with other water treatment equipment" on the previous page.

Installation



Figure 1.
844 shown with bypass assy..

1. Place the system in the desired location.
2. Connect the Cold Water supply to the inlet of the Scaleless system.
NOTE: The Scaleless system operates in the UPFLOW mode which is opposite of a conventional softener.
3. Place a bucket under the outlet port or run a line from the outlet port to a drain.
5. Slowly open the supply valve (user supplied) to the Scaleless system. Allow the tank to fill with water. Close the supply valve when a steady stream of water comes out of the outlet port.
6. Connect the Outlet of the Scaleless system to the cold water supply to the home.
7. Open the supply valve to the Scaleless system.
8. Open faucets downstream from the Scaleless system to relieve any air.
9. Check for leaks. Repair as needed.
10. The system is now ready for service

VERY IMPORTANT: DUE TO UPFLOW CONFIGURATION REQUIRED, MAKE SURE THAT WATER ENTER FROM THE LEFT SIDE OF THE UNIT AND LEAVE FROM THE RIGHT SIDE OF THE UNIT. REFER TO THE PICTURE ABOVE. ALSO NOTE THE STICKERS ON THE ADAPTER.

Manual Bypass (Figure 4A)

In the case of emergency, such as during service, you can isolate your Scaleless System from the water supply using the bypass valve located on the tank.

In normal operation the bypass is open with the on/off knobs in line with the inlet and outlet pipes. To isolate the system, simply rotate the knobs clockwise (as indicated by the word BYPASS and arrow) until they lock.

You can use your water related fixtures and appliances as the water supply is bypassing the system. However, the water you use will be untreated.

To resume treated water service, open bypass valve by rotating the knobs counter-clockwise.

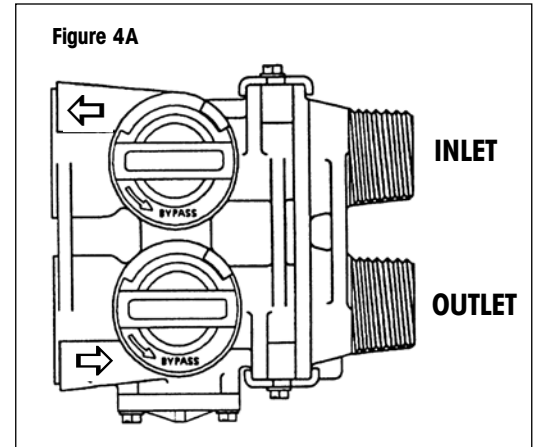

Stainless Steel Bypass (Figure 4B)

In normal operation the bypass lever is aligned with the inlet/outlet with the pointer on SERVICE. To isolate the filter, rotate lever counter clockwise until it stops and pointer indicates unit is in bypass.

You can use your water related fixtures and appliances as the water supply is bypassing the filter. However, the water you use will be unfiltered.

To resume filtered water service, open the bypass valve by reversing the rotation of the lever.

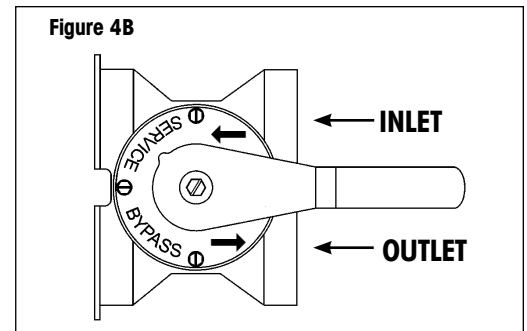

A note to the homeowner

Your Scaleless system will improve the properties of water throughout your home. Here are some things to expect and some recommendations for maximizing the benefits and your enjoyment of Scaleless



Sinks and fixtures - reduced spotting. If water is allowed to evaporate off a surface, small spots may be left behind. If wiped off frequently, the spotting should not require any more than a wet cloth or sponge to remove. No harsh chemical should be required as with typical hard water spotting.



Dishwasher-Spotting on dishes and on the surface of the dishwasher should be greatly reduced. We recommend that you immediately reduce the amount of dishwashing detergent by approximately 50% as compared to hard water use. Dishwashing detergents low in phosphates are highly recommended as they are better for the environment and phosphates can cause spotting. The use of a rinse aid may be advised.



Shower doors and tiles- should have reduced spotting. When water evaporates off a surface, small spots may be left behind. These spots should be easy to remove with a damp cloth or sponge. In very hard water areas treating the shower glass with Rain-X[®] 2 in 1 glass cleaner, or equivalent, will further reduce cleaning requirements.

In the bath you should notice that soaps and shampoos lather more than with un-treated water. Soaps and shampoos will also rinse off much easier and faster than they would with traditional soft water. We recommend the use of modern soaps for the best results.



Things to watch for:

During the first 30-90 days:

- Faucet aerators and drains may plug occasionally as old scale is removed from your plumbing system and water heater.
- You may also see milky water while the descaling is taking place. This is simply an increase in the calcium in the water because Scaleless is removing old scale deposits from your pipes.

Good practices:

If your dishwasher is severely coated with scale at the time of installation, we recommend that you purchase a product like Jet-Dry Dishwasher cleaner to accelerate the cleaning. After this initial cleaning Scaleless should keep it clean.

We also recommend that you drain your water heater tank. This should be done 30 to 60 days after Scaleless is installed, and again in one year. This is a good practice that can dramatically increase the life of your water heating appliance. If you have an electric "tank type" water heater, for optimum results and higher efficiency, we recommend you change the heating elements to a "low watt density" model. Please insure that the watt density is specified at less than 70 watts per square inch, and is compatible with the brand you own. If you can only change one heating element, change the lower unit which operates most of the time. One example is available at Home Depot (SKU # 258184). The Scaleless will help keep the tank and heating elements free of scale and operating at peak efficiency. Please follow the manufacturer's instructions when draining or servicing the tank!

Limited Warranty

WaterGroup Companies Inc. warrants the Scaleless system as follows:

- The Tank is warranted to be free of defects in materials and workmanship for 10 years from the date of original installation.
- The Head is warranted to be free of defects in materials and workmanship for five years from date of original installation.

Conditions

1. The Scaleless system must be installed and serviced by an authorized WaterGroup Companies Inc. dealer, or other entity approved by WaterGroup Companies.
2. Any component failure must not result from abuse, fire, freezing or other acts of nature, violence, or improper installation.
3. Equipment must be installed and operated in compliance with the local plumbing codes, and on an approved water supply.
4. Equipment is limited to use at water pressures not to exceed 100 PSI and temperatures not to exceed 110 degrees F.
5. Water supply must not exceed 3.0-PPM chlorine. For water supply exceeding 3.0 PPM chlorine, pretreatment is required. (Please contact your water treatment specialist.)
6. Information, including model number, serial number, and date of installation, must be provided for any claims pertaining to equipment in warranty.
7. Defective parts are subject to inspection by either WaterGroup Companies Inc. or any authorized representative before final commitment of warranty adjustment is made.
8. WaterGroup Companies Inc. reserves the right to make changes or substitutions in parts or equipment with material of equal quality or value and of then current production.

Limitations

Our obligation under this warranty with respect to the tank or valve is limited to furnishing a replacement for, or at our option, repairing any part or parts to our satisfaction that prove defective within the warranty period stated above. Such replacement parts will be delivered to the owner F.O.B. nearest factory, at no cost, excluding freight and local labor charges, if any.

WaterGroup Companies Inc. shall not be liable for freight, handling or labor charges, or consequential damages.



U.S. Headquarters

WaterGroup Companies, Inc.
193 Osborne Road
Fridley, MN 55432, USA

TOLL FREE PHONE: 1-877-581-1833

Canada Headquarters

WaterGroup Companies, Inc.
490 Pinebush Road, Unit 1
Cambridge, ON N1T 0A5, Canada

TOLL FREE PHONE: 1-877-288-9888

Distribution Locations

Durham, NC
Libertyville, IL
Pottstown, PA
Rancho Cucamonga, CA
Cambridge, ON
Calgary, AB
Regina, SK