

---

# Metermatic Water Softener



## Operation Manual

*Page 5 of this manual contains important maintenance procedures for the continued proper operation of your unit. These MUST be performed regularly for your guarantee to remain valid.*



# Specifications - Cabinet and Twin Tank Models

Model No.	Capacity Grains			Flow Rate		Resin Tank Size Inches	Total Resin Cu Ft	Cabinet/Brine Tank Size Inches W x D X H	Salt Capacity Lbs	Shipping Weight Lbs
	@10 lbs per cu ft	Factory set @ 6 lbs per cu ft	@3 lbs per cu ft	Service USGPM	Backwash USGPM					
<b>Metermatic</b>										
NC24MI*	22,500	<b>17,250</b>	12,000	8	1.5	9 x 35	.75	14 x 22 x 42	250	90
NC32MI*	30,000	<b>23,000</b>	16,000	10	2	10 x 35	1	14 x 22 x 42	240	105
NT24MI	22,500	<b>17,250</b>	12,000	8	1.5	9 x 35	.75	18 x 35	224	85
NT32MI	30,000	<b>23,000</b>	16,000	10	2	10 x 35	1	18 x 35	224	100
NT40MI*	37,500	<b>28,750</b>	20,000	12	2	10 x 47	1.25	21 x 36	308	140
NT64MI*	60,000	<b>46,000</b>	32,000	12	3	12 x 52	2	21 x 36	308	190
NT96MI*	90,000	<b>69,000</b>	48,000	15	4	14 x 65	3	21 x 36	308	230

\*Items include brine tank grid  
**NC** indicates cabinet model, **NT** indicates twin tank model  
 Maximum Water Temperature = 110°F (43°C)  
 Maximum Operating Pressure = 100 PSIG (689 kPa)  
 Voltage = 110 volts standard  
 Pipe Size = 3/4"

- At the stated service flow rates, the pressure drop through these devices will not exceed 15 psig.
- Changing salt settings from factory setting may require changing injector sizes to achieve stated capacities.
- Do not use where water is microbiologically unsafe.
- The manufacturer reserves the right to make product improvements which may deviate from the specifications and descriptions stated herein, without obligation to change previously manufactured products or to note the change.

## How Your Water Conditioner Works

Hard water enters your home through the main supply line, enters your water conditioner and passes down through a bed of ion exchange resin which softens and filters the water as well. An ion exchange process takes place in which the resin beads capture and hold calcium and magnesium, the hardness impurities, while the water takes on sodium ions. The soft water then flows into your household water line.

On the days your conditioner regenerates, the resin is automatically recharged by passing a brine solution (salt water) through it. This reverses the ion exchange process, charging the resin with sodium and freeing the hardness minerals. These minerals and the brine solution are then flushed away through the drain line, followed by a rapid rinse. The resin bed is again ready to soften water. The proper volume of water is returned to the brine tank to dissolve enough salt for the next regeneration. All this is performed automatically.

## Installation and Start-Up Procedure

### Installation Instructions

#### CAUTION:

If the ground from the electrical panel or breaker box to the water meter or underground copper pipe is tied to the copper water lines and these lines are cut during installation of the Noryl bypass valve and/or poly pipe, an approved grounding strap must be used between the two lines that have been cut in order to maintain continuity. The length of the grounding strap will depend upon the number of units being installed and/or the amount of copper pipe being replaced with poly. See Figure 1.

In all cases where metal pipe was originally used and is later interrupted by poly pipe or the Noryl bypass valve as in Figure 1 or by physical separation as in Figure 2, to maintain proper metallic pipe bonding, an approved ground clamp c/w not less than #6 copper conductor must be used for continuity.

Check your local electrical code for the correct clamp and cable size.

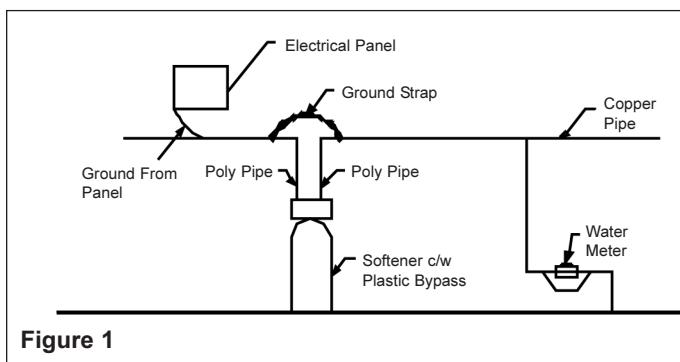

Figure 1

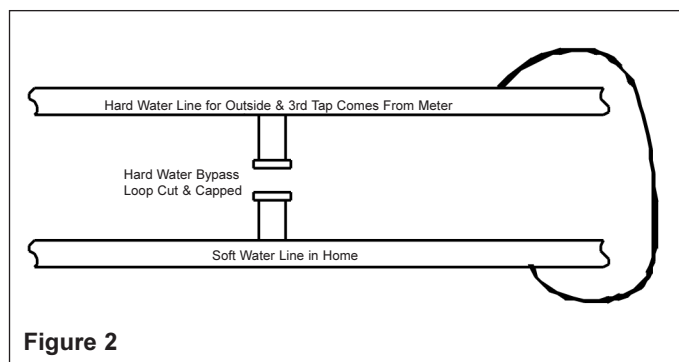
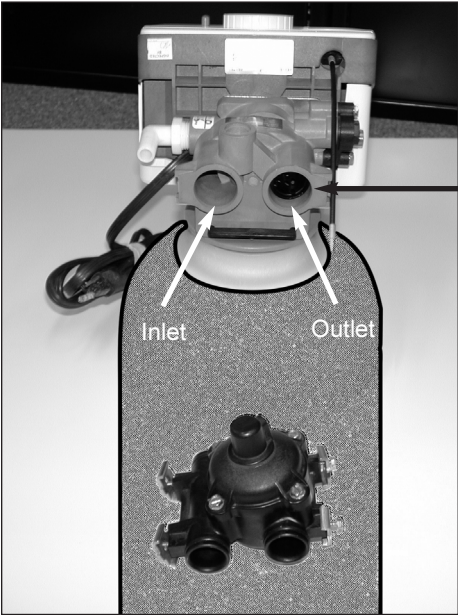

Figure 2

# Procedure to Attach Meter to Valve Assembly

## Step #1



Insert Flow Straightener into outlet side of valve. The pointed side of the flow straightener is to face outward.

## Step #2



Attach meter assembly to valve. Tighten screws attaching meter to the valve

Refer to flow direction arrows (inlet)

## Step #3 - Meter fully attached to valve.



Attach meter cable into meter assembly.

Flow direction arrow

# Installation Instructions

1. Determine the best location for your water softener, bearing in mind the location of your water supply lines, drain line and 120 volt AC electrical outlet. Subjecting the softener to freezing or temperatures above 49°C (120°F) will void the warranty.
2. Water to supply outside faucets used to water lawns and gardens should not be softened. A new water line is often required to be connected to supply hard water to the inlet of the water softener and to the outside faucets. Cut the water line between where it enters the house; before any lines that branch off to feed the hot water heater or other fixtures in the house; and as near the desired location of the water softener as possible. Install a tee fitting on the feed end of the cut pipe and an elbow fitting on the other end. Install piping from the tee to the inlet of the water softener and from the elbow to the outlet to the softener. To serve the water lines which branch off to feed outside faucets, cut the branch lines approximately two inches from the fitting on the main water line. Install an elbow on the end of the pipe nearest the outside faucet and a cap on the end connected to the existing water line. Install piping from the tee on the inlet to the water softener to the elbow on the pipe to the outside faucet. Following this procedure will result in all lines in the house, with the exception of the outside faucets but including the water heater and therefore the hot water lines, being supplied with soft water.

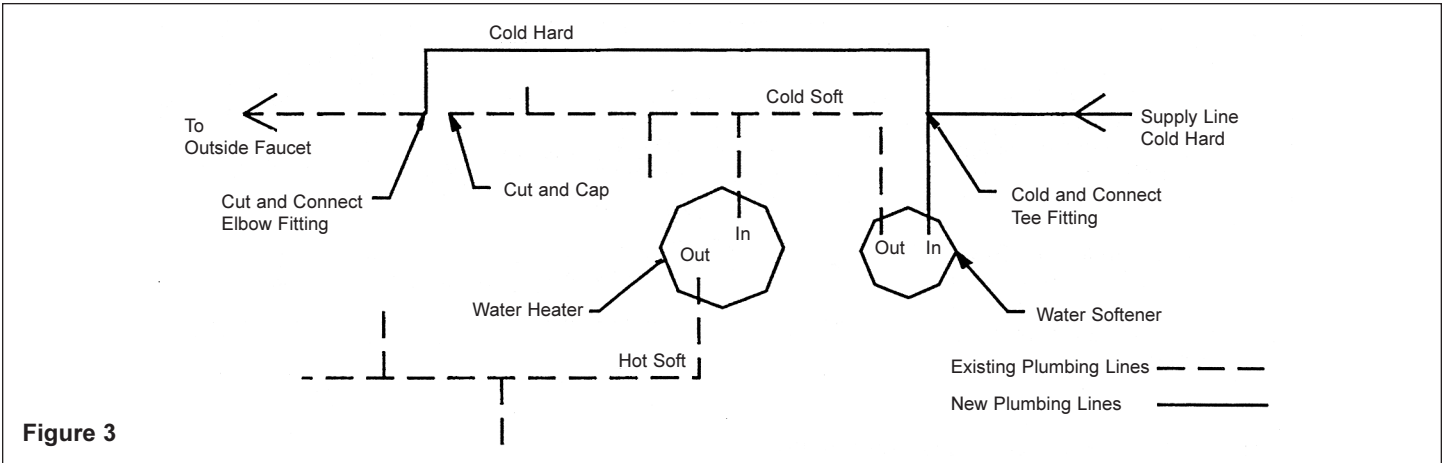

Figure 3

3. Familiarize yourself with the location of the inlet, outlet and drain on the control valve. Be very careful not to get the controls wet.
4. The inlet and outlet of the valve are marked with arrows. Attach the bypass valve to the control valve. When sweat fittings are used, solder the adapters for the inlet and outlet to a short length of copper pipe first. This procedure is necessary because the controls **MUST NOT** be subjected to temperatures above 160°F. Then, using teflon tape, screw the adapters for the inlet, outlet and drain into the valve.

**CAUTION - do not use pipe thread compound as it may attack the material in the valve body.**

On the drain, use the 1/2" hose barb supplied and a full 1/2" hose for the drain line. A restriction at the drain can cause any automatic water conditioner to malfunction. Place the conditioner in position and complete the plumbing necessary for the installation. Generally, water to outdoor faucets and sprinklers should not be softened.

5. Set the 24 hour timer and frequency of regeneration following instructions on page 4.
6. Turn the large knob to the backwash position. Turn on the water supply to the valve and wait until water starts running at the drain. Allow the water to run at the drain for 2 to 3 minutes.
7. Optional (Skip to step 8 if disinfection is not desired) - We recommend that all new water softeners be disinfected prior to start up. Disinfection can be achieved by the application of chlorine (household bleach). Manually turn the knob to the start of the BRINE REFILL position. The correct amount of water will be automatically metered through the air check tube in the brine well into the brine tank. Add one (1) teaspoon of chlorine (household bleach) to the brine tank and mix the chlorine and water solution. Turn the knob, advancing the valve to the BRINE/RINSE position. Plug the softener in and the valve will automatically return to the SERVICE position.
8. Plug the softener in. Manually turn the knob to the start of the BRINE REFILL position. The correct amount of water will be automatically metered through the air check tube in the brine well into the brine tank, and the control will automatically return to the SERVICE position. The SERVICE position is indicated by the word SOFT WATER on the central dial.
9. Replace timer cover.
10. Put a minimum of 40 Kgs of Crystal water softener salt in the brine tank. The unit will fit to the correct level when it regenerates automatically the next time.
11. Make sure that bypass valve is left in the normal service position.

**ALL GOVERNMENT CODES GOVERNING INSTALLATION OF THESE DEVICES MUST BE OBSERVED.**

# Operating Instructions

## Water Pressure

Your softener is designed to operate under normal water pressures from 20 psi (1.4 atm) to 120 psi (8.2 atm).

## Regeneration and Automatic Bypass

Water conditioners are factory set to regenerate at 2:00 AM during a period of little or no water use. The regeneration cycle lasts approximately three hours, after which soft water service is restored. While regeneration is taking place, hard water automatically bypasses the water conditioner if required. Use of water, particularly hot water, should be avoided at this time to prevent hard water from filling the water heater.

## Manual Bypass (Figure 4)

In the case of emergency, such as an overflowing brine tank, you can isolate your water softener from the water supply using the bypass valve located at the back of the control.

In normal operation the bypass is open with the on/off knobs in line with the inlet and outlet pipes. To isolate the softener, simply rotate the knobs clockwise (as indicated by the word BYPASS and arrow) until they lock.

You can use your water related fixtures and appliances as the water supply is bypassing the softener. However, the water you use will be hard.

To resume soft water service, open bypass valve by rotating the knobs counter-clockwise.

## New Sounds

You will notice new sounds, such as the hum of the timer, as your water conditioner operates. During regeneration, it will not be uncommon to hear the sounds of water running the drain.

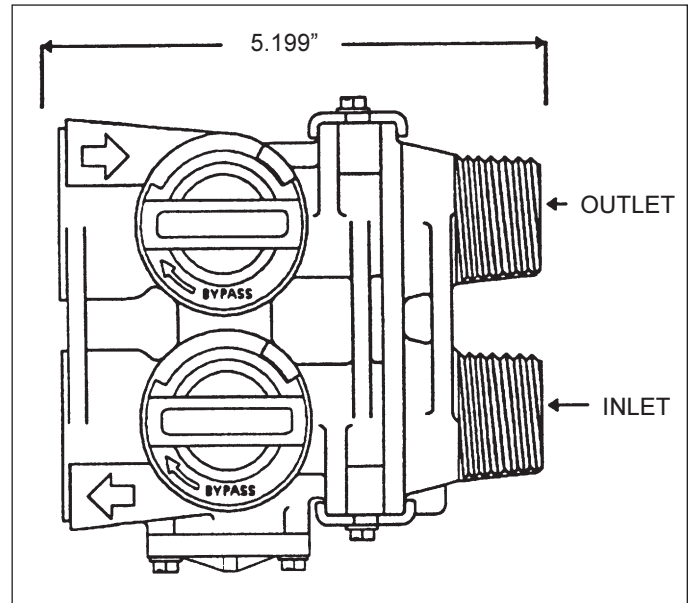

Figure 4

# Programming Demand Regeneration Controls

## Setting the 24 Hour Timer (Figure 5)

This is a 24-hour timer and must correspond with the correct time on your wrist watch to ensure proper cycling of your softener. Disengage the drive gear by pressing and holding in the RED BUTTON on the left side of the control. Now turn the large dial until the actual time of day is at the time of day arrow, at the bottom of the panel. Release the red button to re-engage the drive gear. The correct time of day on the 24-hour clock has now been set.



Figure 5

## Setting the Frequency of Automatic Regeneration (Figure 6)

There are two methods for setting the program wheel - use only one of the following methods.

### Method 1

Set the program wheel by lifting the “people” dial and rotating it so the number of people in the household is aligned with the grains per gallon water hardness scale. Release the dial and check for firm engagement at setting. (This method will provide reserve capacity based on 75 gallons per person per day.)

### Method 2

The frequency of automatic regeneration can alternatively be set by using the gallon label and the small white dot on the program wheel. To set the program wheel, grasp it and while pulling it toward you, turn it until the desired number of gallons is aligned with the white dot on the circumference. The number of gallons is read by multiplying the number on the label by 100. To determine the number of gallons of softened water that can be produced between regenerations, use the following formula:

Capacity of your conditioner (see Specifications Page 1)

÷ Grains of compensated\* hardness in water sample

= Number of gallons between regenerations

– Reserve (number of people x 75 gallons)

= No. of gallons at which to set the program wheel

\*For each part per million of iron in the sample include 4 gpg in hardness calculation



Figure 6

## Manually Initiating Regeneration (Figure 7)

Should you run out of soft water due to inadequate frequency of regenerations or inadequate reserve capacity, power failures, lack of salt, or excessive usage because of unexpected company, you can initiate a manual regeneration simply by turning the large knob on the front of the control to the “REGEN” position. The softener will now automatically complete a regeneration cycle and return to service. Be sure there is adequate salt and salt brine in the brine tank for a satisfactory regeneration.



Figure 7

# Maintenance Instructions

Maintenance of your new water conditioner requires very little time or effort, however, it is essential. Regular maintenance will ensure many years of trouble free and efficient operation.

## Adding Salt

Use only crystal water softener salt. Check the salt level monthly. It is important to maintain the salt level above the water level. To add salt, simply lift the salt lid and add the salt directly into the brine tank. Be sure the brine well cover is on and fill only to the height of the brine well.

## Caution

Liquid brine will irritate eyes, skin and open wounds. Gently wash exposed area with fresh water. Keep children away from your water conditioner.

## Resin Cleaner

An approved resin cleaner **must** be used on a regular basis if your water supply contains iron. The amount of resin cleaner and frequency of use is determined by the quantity of iron in your water (consult your local representative or follow the directions on the resin package).

## Care of Your Water Conditioner

To retain the attractive appearance of your new water softener, clean occasionally with mild soap solution. Do not use abrasive cleaners, ammonia or solvents. Never subject your softener to freezing or to temperatures above 120°F.

## Bridging (Figure 8)

Humidity or wrong type of salt may create a cavity between the water and the salt. This action, known as "bridging", prevents the brine solution from being made, leading to your water supply being hard.

If you suspect salt bridging, carefully pound on the outside of the brine tank or pour some warm water over the salt to break up the bridge. This should always be followed up by allowing the unit to use up any remaining salt and then thoroughly cleaning out the brine tank. Allow four hours to produce a brine solution, then manually regenerate the softener.

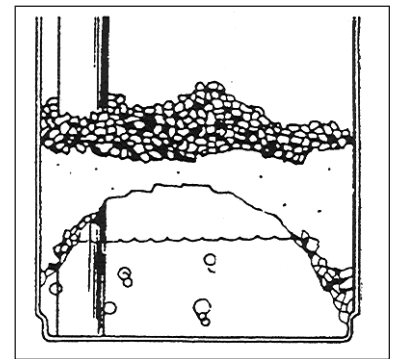

Figure 8

## Cleaning the Injector Assembly (Figure 9)

Sediment, salt and silt will restrict or clog the injector. A clean water supply and pure salt will prevent this from happening.

The injector assembly is located on the right side of the control valve. This assembly is easy to clean.

Shut off the water supply to your softener and reduce the pressure by opening a cold soft water faucet. Using a screwdriver, remove the two screws holding the injector cover to the control valve body. Carefully remove the assembly and disassemble as shown in Figure 9. The injector orifice is removed from the valve body by carefully turning it out with a large screwdriver. Remove the injector throat the same way. Carefully flush all parts including the screen. Use a mild acid such as vinegar or Pro-Rust Out to clean the small holes in the orifice and throat.

Reassemble using the reverse procedure.

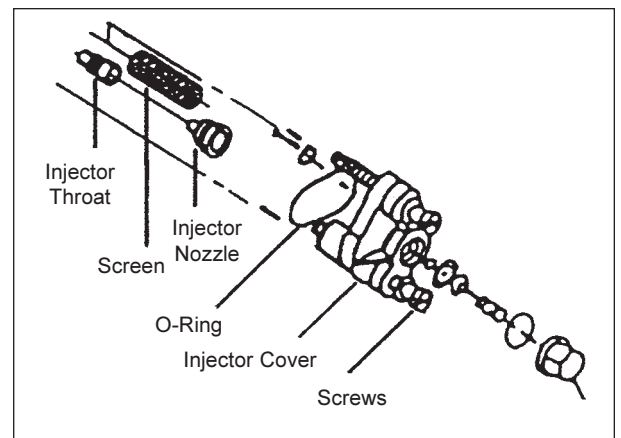

Figure 9



# Trouble Shooting Guide

Before calling for service, follow the steps below, then MANUALLY REGENERATE your softener.

PROBLEM	CAUSE	CORRECTION
1. Softener delivers hard water	<ul style="list-style-type: none"> <li>A. Bypass valve is open</li> <li>B. No salt in brine tank</li>   <li>C. Injector or screen plugged</li> <li>D. Insufficient water flowing into brine tank</li>   <li>E. Electrical service to unit has been interrupted</li>   <li>F. Salt bridged</li> <li>G. Loose brine line</li> <li>H. Plugged injector assembly</li> <li>I. Reserve capacity has been exceeded-demand regeneration models only</li> <li>J. Program wheel is not rotating with meter output-demand regeneration models only</li>   <li>K. Meter is not measuring flow-demand regeneration models only</li> </ul>	<ul style="list-style-type: none"> <li>A. Close bypass valve.</li> <li>B. Add salt to brine tank and maintain salt level above water level.</li> <li>C. Replace injectors and screen.</li> <li>D. Check brine tank fill time and clean brine line flow control if plugged.</li> <li>E. Assure permanent electrical service (check fuse, plug or switch).</li> <li>F. Break salt bridging – see page 5.</li> <li>G. Tighten connections at control valve and at brine valve.</li> <li>H. Clean assembly following instructions on page 6.</li> <li>I. Check salt dosage requirements and reset program wheel to provide additional reserve.</li> <li>J. Pull cable out of meter cover and rotate manually. Program wheel must move without binding and clutch must give positive “clicks” when program wheel strikes regeneration stop. If it does not, replace timer.</li> <li>K. Check output by observing rotation of small gear on front of timer program wheel must not be against regeneration stop for this check). Each tooth to tooth is approximately 30 gallons. If not performing properly, replace timer.</li> </ul>
2. Intermittent soft water	<ul style="list-style-type: none"> <li>A. Control will not draw brine properly</li>   <li>B. Using hot water during regeneration cycle</li> <li>C. Loose wiring or connections</li> <li>D. Leaky faucet</li> <li>E. Water hardness increased</li> <li>F. Softener capacity too small</li> </ul>	<ul style="list-style-type: none"> <li>A. Maintain water pressure at 20 psi minimum. Check for restrictions in drain line. Clean or replace injector assembly. Check for air leaks between control valve and air check valve and tighten connections.</li> <li>B. Avoid using hot water at this time as water heater will fill with hard water.</li> <li>C. Unplug softener and check that all wires are securely connected.</li> <li>D. Check and repair plumbing leaks that can cause you to run out of soft water.</li> <li>E. Have samples of your water analyzed to determine any change in hardness.</li> <li>F. Increase capacity by replacing with larger unit.</li> </ul>
3. Softener fails to regenerate or regenerates at wrong time	<ul style="list-style-type: none"> <li>A. Electrical service to unit has been interrupted.</li> <li>B. Timer is defective</li> <li>C. Power failure</li> </ul>	<ul style="list-style-type: none"> <li>A. Assure permanent electrical service (check fuse, plug, pull chain or switch). Reset time of day.</li> <li>B. Replace timer.</li> <li>C. Reset time of day.</li> </ul>
4. Unit uses too much salt	<ul style="list-style-type: none"> <li>A. Improper salt setting</li> <li>B. Excessive water in brine tank</li> </ul>	<ul style="list-style-type: none"> <li>A. Check salt usage and salt setting.</li> <li>B. See problem 8.</li> </ul>
5. Loss of water pressure	<ul style="list-style-type: none"> <li>A. Inlet to control blocked with iron buildup or foreign matter</li> <li>B. Iron buildup in water conditioner</li> </ul>	<ul style="list-style-type: none"> <li>A. Clean line to water conditioner. Remove piston and clean control.</li> <li>B. Clean control and add resin cleaner to resin bed.</li> </ul>
6. Loss of resin through drain line	<ul style="list-style-type: none"> <li>A. Air in water system</li> </ul>	<ul style="list-style-type: none"> <li>A. Assure that well system has proper air eliminated control. Check for dry well condition.</li> </ul>
7. Iron in conditioned water	<ul style="list-style-type: none"> <li>A. Fouled resin bed</li> </ul>	<ul style="list-style-type: none"> <li>A. Check backwash, brine draw and brine tank fill. Increase frequency of regeneration.</li> </ul>

<b>PROBLEM</b>	<b>CAUSE</b>	<b>CORRECTION</b>
8. Excessive water in brine tank	<ul style="list-style-type: none"> <li>A. Plugged drain line flow control</li> <li>B. Plugged injector system</li> <li>C. Foreign material in brine valve</li> <li>D. Foreign material in brine line flow control</li> </ul>	<ul style="list-style-type: none"> <li>A. Clean flow control.</li> <li>B. Clean injector and replace screen.</li> <li>C. Clean or replace brine valve.</li> <li>D. Clean brine flow control.</li> </ul>
9. Softener fails to draw brine	<ul style="list-style-type: none"> <li>A. Drain line flow is plugged</li> <li>B. Injector is plugged</li> <li>C. Injector screen is plugged</li> <li>D. Line pressure is too low</li> <li>E. Internal control leak</li> </ul>	<ul style="list-style-type: none"> <li>A. Clean drain line flow control.</li> <li>B. Clean or replace injectors.</li> <li>C. Replace screen.</li> <li>D. Increase line pressure. Line pressure must be at least 20 psi (139.9 KPa) at all times.</li> <li>E. Change seals and spacers and/or piston assembly.</li> </ul>
10. Control cycles continuously	<ul style="list-style-type: none"> <li>A. Faulty timer mechanism</li> </ul>	<ul style="list-style-type: none"> <li>A. Replace timer.</li> </ul>
11. Drain flows continuously	<ul style="list-style-type: none"> <li>A. Foreign material in control</li> <li>B. Internal control leak</li> <li>C. Control valve jammed in brine or backwash position</li> <li>D. Timer motor stopped or jammed</li> </ul>	<ul style="list-style-type: none"> <li>A. Remove piston assembly and inspect bore, remove foreign material. Check control in various regeneration positions.</li> <li>B. Replace seals and/or piston assembly.</li> <li>C. Replace piston and seals and spacers.</li> <li>D. Replace timer control.</li> </ul>



# Guarantee

**Novatek** guarantees that your new water conditioner is built of quality material and workmanship. When properly installed and maintained, it will give years of trouble free service.

**Seven Year Complete Parts Guarantee:**

**Novatek** will replace any part which fails within 84 months from date of manufacture, as indicated by the serial number provided the failure is due to a defect in material or workmanship. The only exception shall be when proof of purchase or installation is provided and then the warranty period shall be from the date thereof.

**Lifetime Guarantee on Mineral Tanks and Brine Tanks:**

**Novatek** will provide a replacement mineral tank or brine tank to any original equipment purchaser in possession of a tank that fails within his/her lifetime, provided that the water conditioner is at all times operated in accordance with specifications and not subject to freezing.

**General Provisions:**

**Novatek** assumes no responsibility for consequential damage, labor or expense incurred as a result of a defect or for failure to meet the terms of these guarantees because of circumstances beyond its control.

# NOVATEK

**WaterGroup Inc.**  
Fridley, Minnesota  
Sun Valley, California  
1-800-354-7867

**WaterGroup Companies Inc.**  
Regina, Saskatchewan  
Cambridge, Ontario  
1-877-288-9888

[www.watergroup.com](http://www.watergroup.com)

Printed in Canada