

---

# **Novaclean Automatic Water Filters**



## **Operation Manual**

*ACF Activated Carbon Filter, MMF Multimedia Filter, NF Neutralizing Filter*

*Page 5 of this manual contains important maintenance procedures required for the continued proper operation of this unit. These **MUST** be performed regularly for your guarantee to remain valid.*

## Novaclean ACF - Specifications

Model Description	Carbon Cu Ft	Flow Rates USGPM			Installation Space Inches - W x D x H	Fiberglass Tank Size - Inches	Shipping Weight - Lbs
		Service	Peak	Backwash			
NACF75	.75	4	5	3.5	10 x 10 x 57	8 x 47	45
NACF10	1.0	5	7	5	12 x 12 x 57	10 x 47	65
NACF15	1.5	7	10	7	14 x 14 x 62	12 x 52	93
NACF20	2.0	10	12	10	16 x 16 x 60	14 x 50	105

## Novaclean MMF - Specifications

Model Description	Media Cu Ft	Flow Rates USGPM			Installation Space Inches - W x D x H	Fiberglass Tank Size - Inches	Shipping Weight - Lbs
		Service	Peak	Backwash			
NMMF75	.75	4	5	4	10 x 10 x 57	8 x 47	95
NMMF10	1.0	5	7	5	11 x 11 x 58	9 x 48	145
NMMF15	1.5	7	10	7	12 x 12 x 64	10 x 54	213
NMMF20	2.0	10	12	10	14 x 14 x 62	12 x 52	265

## Novaclean NF - Specifications

Model Description	Media Cu Ft	Flow Rates USGPM			Installation Space Inches - W x D x H	Fiberglass Tank Size - Inches	Shipping Weight - Lbs
		Service	Peak	Backwash			
NNF75	.75	2	3.5	3.5	10 x 10 x 57	8 x 47	75
NNF10	1.0	3	5	4	11 x 11 x 58	9 x 48	115
NNF15	1.5	5	8	5	12 x 12 x 64	10 x 54	165
NNF20	2.0	6	10	7	14 x 14 x 62	12 x 52	215

- Peak flow rates intended for intermittent use only (10 minutes or less) and are for residential applications only. Do not use peak flow rates for commercial applications.
- At the stated flow rates, the pressure drop through these devices will not exceed 15 psig.
- For satisfactory operation, the pumping rate of the well system must equal or exceed indicated backwash flow rate.
- Maximum Water Temperature = 110°F (43°C)
- Maximum Operating Pressure = 100 PSIG (689 kPa)
- Pipe Size = 3/4"
- Voltage = 110V Standard
- The manufacturer reserves the right to make product improvements which may deviate from the specifications and descriptions stated herein, without obligation to change previously manufactured products or to note the change.

## Typical Installations

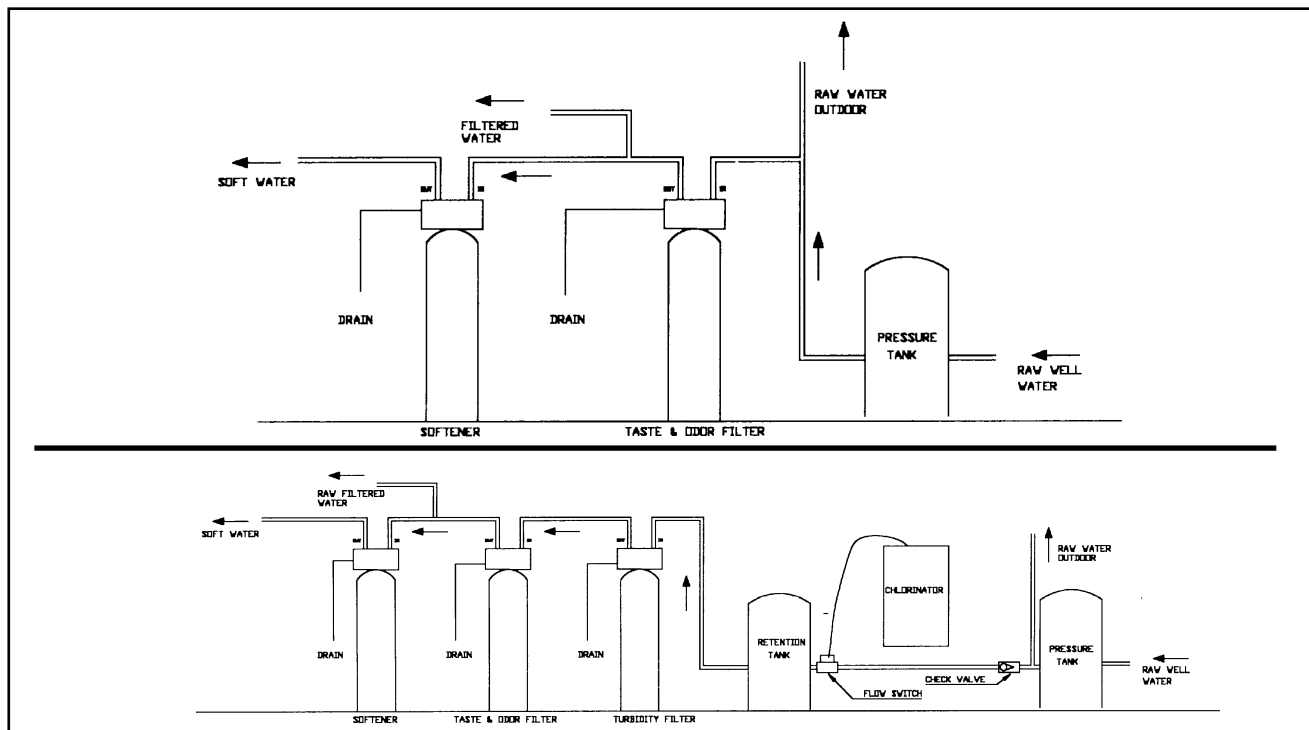

NOTE: A neutralizing filter is the first unit installed in a water system after the outdoor raw water lines (\*) when pH correction is required.

# Installation and Start-up Procedure

## Installation Instructions

### CAUTION:

If the ground from the electrical panel or breaker box to the water meter or underground copper pipe is tied to the copper water lines and these lines are cut during installation of the Noryl bypass valve and/or poly pipe, an approved grounding strap must be used between the two lines that have been cut in order to maintain continuity. The length of the grounding strap will depend upon the number of units being installed and/or the amount of copper pipe being replaced with poly. See Figure 1.

In all cases where metal pipe was originally used and is later interrupted by poly pipe or the Noryl bypass valve, as in Figure 1 or by physical separation as in Figure 2, to maintain proper metallic pipe bonding, an approved ground clamp c/w not less than #6 copper conductor must be used for continuity.

Check your local electrical code for the correct clamp and cable size.

**NOTE:** This timer's programs will be out of sync if you turn the knob too far or do not allow the drive motor to stop completely before continuing to the next step. If this happens while doing any procedure, rotate the knob clockwise until the white dot lines up with the time of day arrow and the unit will return to the service position. You can then start again.

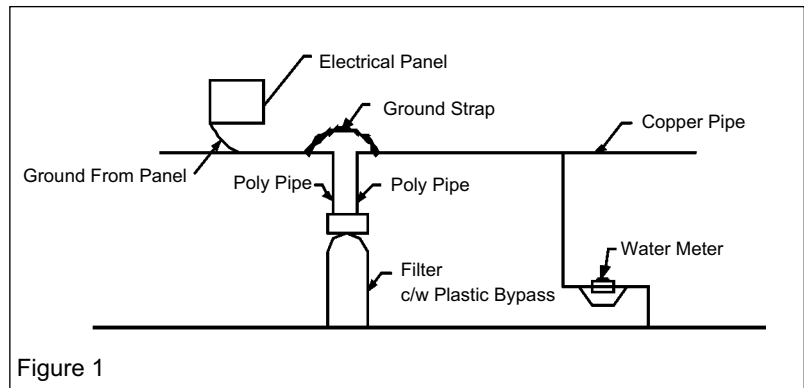

Figure 1

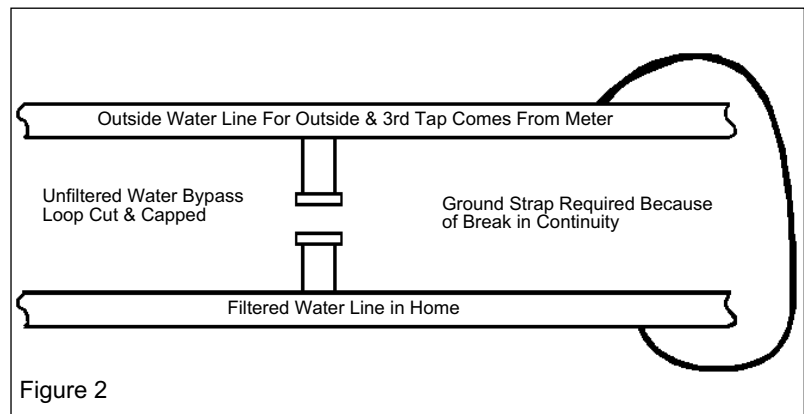

Figure 2

1. Place filter on a flat surface in desired location, near a drain and 115 volt AC outlet. Subjecting your filter to freezing or to water temperatures above 120°F (49°C) will void the warranty. Remove the valve from the carton. Be sure the distributor tube is in place. Carefully position the valve over it and turn securely on to the fiberglass tank.

**Note:** All multi media and some larger units are supplied with the media separate. Please refer to page 5 Installations & Replacement of Filter Media Pak.

2. Attach the installation kit or bypass to the control valve. Make inlet and outlet water connections to meet applicable plumbing codes. A 3/4" inlet line is recommended. When sweat fittings are used, solder the adapters for the inlet and outlet to the copper pipe first. This procedure is necessary because the controls **must not** be subjected to temperatures above 160°F (71°C). Then, using teflon tape, screw the adapters for the inlet, outlet and drain into the valve. **CAUTION:** do not use pipe thread compound as it may attack the materials in the valve body.
3. On the drain, use 1/2" hose barb supplied and full 1/2" hose (not supplied) for the drain line and make the shortest run to a suitable drain. The drain line must be secured in position at the end which discharges into the drain so it cannot be inadvertently moved from the drain.
4. Loosen the two screws on the timer cover to remove it from the timer.
5. Automatic water filters are supplied from the factory in the backwash position, ready for start up. Turn on the water supply to the unit. Open the supply line slowly and allow the air to escape from the filter before turning the supply water on all the way. Allow the unit to backwash until all the air and media fines are no longer showing at the drain. This may take up to 15 minutes so you need to unplug the timer until you are ready to continue.
6. Plug the timer in, set the time and frequency of regeneration following instruction on page 4. Allow the unit to complete the cycle on its own from this point.
7. Make sure the bypass valve is in the service position.

**ALL GOVERNMENT CODES GOVERNING INSTALLATIONS OF THESE DEVICES MUST BE OBSERVED.**

# Operating Instructions

## How Your Automatic Filter Works

Raw water enters your home through the main supply line, enters your filter, and passes downward through the media bed. Impurities such as turbidity and sediment (MMF) and organics (ACF) are removed from the water. The filtered water then flows up and into your household water lines.

The neutralizing filter (NF) is designed to raise the pH of your water to eliminate corrosive characteristics.

**EXAMPLE:** A pH of 5.5 can be raised to 7.0 which is neutral. When the water is neutralized it is then possible to remove the iron with the addition of an iron filter.

## Water Pressure

Your water filter is designed to operate under normal water pressures from 20 psi to 125 psi.

## Regeneration and Automatic Bypass

Water filters are factory set to regenerate at 1:00 a.m. during a period of little or no water use. The regeneration cycle lasts approximately 15 minutes, after which filtered water service is restored. While regeneration is taking place, “raw water” automatically bypasses the filter if required. If possible, avoid using water during regeneration to prevent unfiltered water entering your household plumbing system. Note: When more than one filter is being used, regeneration should be staggered by 15 minute intervals from 1 a.m.

## Manual Bypass (Figure 3A)

In case of an emergency, you can isolate your water filter from the water supply using the bypass valve located at the back of the control.

In normal operation the bypass is open with the on/off knobs in line with the inlet and outlet pipes. To isolate the filter, simply rotate the knobs clockwise (as indicated by the word BYPASS and arrow) until they lock. You can use your water related fixtures and appliances as the water supply is bypassing the filter. However, the water you use will be unfiltered.

To resume filtered water service, open the bypass valve by rotating the knobs counter-clockwise.

## Stainless Steel Bypass (Figure 3B)

In normal operation the bypass lever is aligned with the inlet/outlet with the pointer on SERVICE. To isolate the filter, rotate lever counter clockwise until it stops and pointer indicates unit is in bypass.

You can use your water related fixtures and appliances as the water supply is bypassing the filter. However, the water you use will be unfiltered.

To resume filtered water service, open the bypass valve by reversing the rotation of the lever.

## New Sounds

You will notice new sounds, such as the hum of the timer, as your filter operates. During regeneration, it will not be uncommon to hear water running to the drain.

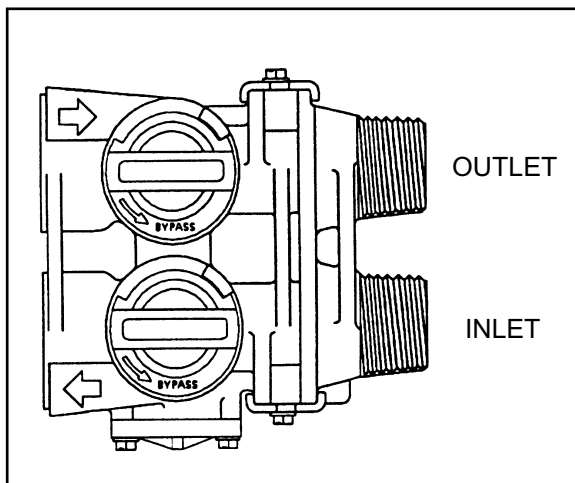

Figure 3A

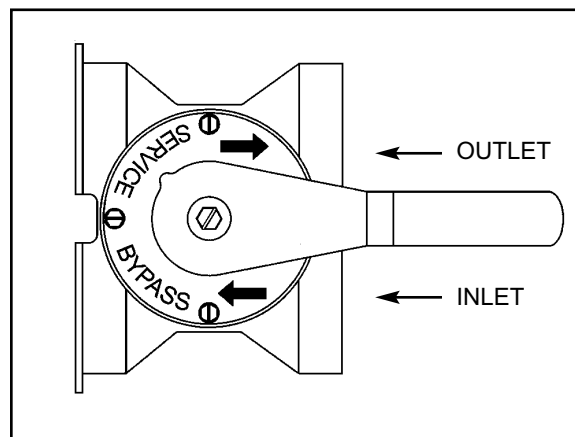

Figure 3B

# Programming Backwash Controls

## Setting The 24-Hour Timer

Press and hold the red button in to disengage the drive gear. Turn the large dial until the actual time of day is opposite the time of day pointer. Release the red button to re-engage the drive gear.

## Determining The Backwash Frequency

The following table can be used to help determine the frequency of regeneration. Use this table as a guide – individual circumstances will require more or less frequent regenerations.

To set a neutralizing filter follow the table under mild conditions.

**NOTE:** Add one person if you have a dishwasher.

MMF FILTERS	SEDIMENT TURBIDITY	MILD	AVERAGE	EXTREME												
ACF FILTERS	TASTE ODOR	MILD	AVERAGE	EXTREME												
No. of Persons	Calendar Clock Regeneration Frequency - No. of Tabs Pushed outwards															
2	1	1	1	1	1	2	2	2	2	2	3	3	3	3	3	3
3	1	1	2	2	3	3	3	3	3	3	4	4	4	4	4	4
4	1	2	2	2	3	3	3	4	4	4	6	6	6	6	6	6
5	2	2	3	3	4	4	4	4	4	6	6	6	6	12	12	12
6	2	2	3	3	4	4	4	4	6	6	6	6	12	12	12	12
7	2	3	3	4	4	6	6	6	12	12	12	12	12	12	12	12
8	2	3	3	4	6	6	6	6	12	12	12	12	12	12	12	12
9	3	3	4	4	6	6	12	12	12	12	12	12	12	12	12	12
10	3	4	4	6	6	12	12	12	12	12	12	12	12	12	12	12

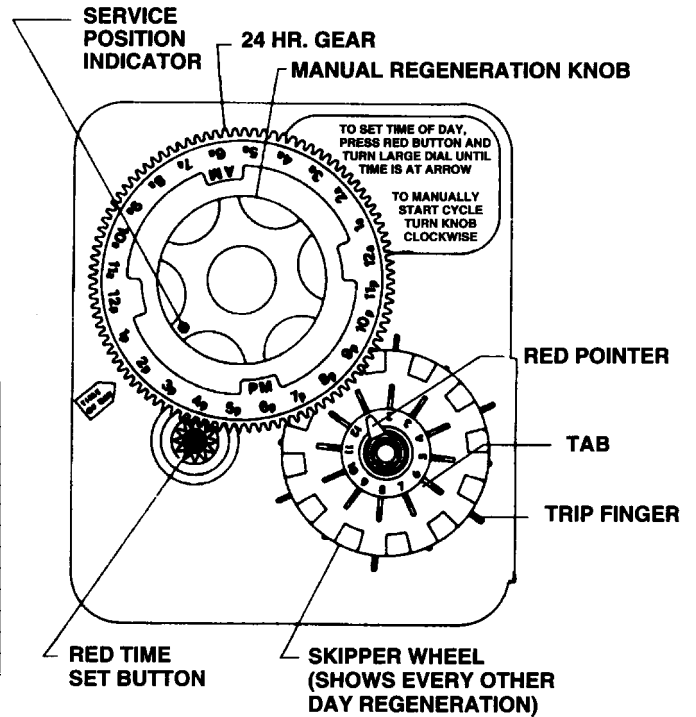

## Setting The Backwash Frequency

The filter control features a skipper wheel with twelve numbered tabs and trip fingers. Each represents one day of a twelve day schedule. By adjusting the skipper wheel tabs, the control can be programmed to backwash every second, third, fourth, sixth or twelfth day, according to your requirements.

The control is shipped with all the skipper wheel tabs pushed outwards. You must push the tabs in toward the center of the wheel (retracting the trip finger) for each day that backwashing is not required.

Rotate the skipper wheel until number “1” is at the pointer, leave this tab out. Moving clockwise round the skipper wheel adjust the remaining tabs using the following table as a guide.

No. of backwashes required in 12 days	Skipper Wheel Tab Settings											
	1	2	3	4	5	6	7	8	9	10	11	12
1	Out	In	In	In	In	In	In	In	In	In	In	In
2	Out	In	In	In	In	In	In	In	In	In	In	In
3	Out	In	In	In	Out	In	In	In	Out	In	In	In
4	Out	In	In	Out	In	In	Out	In	In	Out	In	In
6	Out	In	Out	In	Out	In	Out	In	Out	In	Out	In

## Manual Regeneration

Turn the manual regeneration knob clockwise. This slight movement of the manual regeneration knob engages the program wheel and starts the regeneration process. The back center knob will make one revolution in approximately three hours and stop in the position shown in the drawing. Actual backwash time is 14 minutes. In any event, treated water may be drawn after rinse water stops flowing from the filter’s drain line.

# Maintenance Instructions

Maintenance of your new water filter requires very little time or effort but it is essential. Regular maintenance will ensure many years of efficient and trouble free operation.

## Care of All Water Filters

To retain the attractive appearance of your new water filter, clean occasionally with a mild soap solution. Do not use abrasive cleaners, ammonia or solvents. Never subject your filter to freezing or to water temperatures above 120°F.

## Replacing Media Bed

**NF** - the media bed in a neutralizing filter is slowly dissolved and has to be replaced. The frequency of replacement varies, depending on water quality – consult your dealer to determine the expected life of your media bed.

**ACF** - under normal operating conditions the effective life of the filter media is approximately one to three years depending on the water quality, after which, taste and odor problems may return. When this happens contact your dealer for a replacement media bed.

**MMF** - under normal operating conditions, the media should never need to be replaced. If you experience pressure loss and cannot correct it with a manual regeneration, your media bed may need replacing – contact your dealer.

## Installation & Replacement of Filter Media Pak

Check to ensure all media parts are received.

The first step in replacing the media bed is to shut off the water supply to the filter. Then place the unit into the backwash position to release any pressure in the lines. At this point, you must disconnect the plumbing from the inlet and outlet. Then unscrew the control valve (Item A) from the fiberglass tank. Once this has been done, remove the distributor tube (Item B). Then you can remove the filter media and two types of gravel from the tank. The quickest way to do this is by simply tipping the tank upside down into a large drum or pail. The tank must be rinsed out completely and have no media or gravel left in it at all.

### Loading the Media-Pak

Place the distributor tube (Item B) back down the center of the tank. The top of this tube should be plugged with a rag or cork to prevent media from entering. Pour the bag of coarse gravel (Item E) into the tank, then pour the bag of fine gravel (Item D) into the tank.

***It is important that the distributor tube is not moved or pulled out as it would not be possible to put it down to the bottom of the tank once gravel or media are in the tank.***

Finally pour the larger bag(s) of media into the tank.

For multi-media units only. These units have to be loaded in the following order:

1. Coarse gravel (1/2 x 1/4)
2. Fine gravel (1/8 x 1/16)
3. Coarse garnet (8 x 12)
4. Fine garnet (30 x 40)
5. Fine filter sand (.45 x .55)
6. Anthrafilt

Once this is done, the rag or cork should be removed from the distributor tube. Clean off the top of the tank. Finally place the control valve on the tank and onto the distributor tube. Tighten the control valve onto the tank. Connect or reconnect the inlet and outlets and drain. The control valve should be in the backwash position. Slowly open the inlet valve water supply and slowly fill the filter tank until water appears at the open drain line (Item F). Return the control to the service position and shut the inlet off for approximately one hour to allow the media to soak in the water.

After one hour, turn inlet water on slowly and place the control into the backwash position and plug the unit's electrical cord into a constant power source. Let the unit continue through its regeneration cycle automatically.

The regeneration is necessary so all media fines are backwashed down the drain to ensure clean filtered water. After this media has been replaced, it may be necessary to reset the present time of day on the control valve timer as it will have been unplugged for some time.

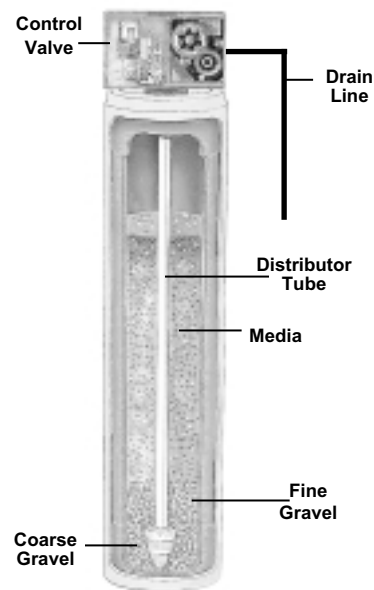

# Trouble Shooting Guide

PROBLEM	CAUSE	CORRECTION
1. Filter bleeds taste and odor or sediment	<p>Bypass valve is open</p> <p>Electrical service to unit has been interrupted</p> <p>Defective or stripped media bed</p> <p>Quality of water has worsened</p> <p>Filter capacity too small</p> <p>Filter not backwashing enough</p> <p>Excessive water usage</p> <p>Tabs on skipper wheel not out</p>	<p>Close bypass valve.</p> <p>Assure permanent electrical service (check fuse, plug or switch).</p> <p>Replace media.</p> <p>Have water sample analyzed to determine any change.</p> <p>Replace with larger unit or add another filter.</p> <p>Be sure control is not clogged or drain line restricted. Be sure water pressure has not dropped and that pump has sufficient capacity.</p> <p>Increase frequency of regeneration. Make sure there are no leaks in toilets or sinks.</p> <p>Push as many tabs to the outside of the skipper wheel as necessary to provide adequate frequency of regeneration.</p>
2. Filter fails to regenerate	<p>Electrical service to unit has been interrupted</p> <p>Timer is defective</p> <p>Power failure</p> <p>Broken cogs on the 24 hour gear</p> <p>Timer motor does not run</p>	<p>Assure permanent electrical service (check fuse, plug or switch).</p> <p>Replace timer.</p> <p>Reset time of day.</p> <p>Replace 24 hour gear.</p> <p>Replace defective motor.</p>
3. Filter regenerates every day	<p>Faulty gear train</p>	<p>Check the mechanical linkage on the timer control to eliminate possible binding in the gear train.</p>
4. Loss of water pressure	<p>Iron or turbidity build-up in filter</p> <p>Filter not regenerating often enough</p> <p>Not enough water volume or pressure to backwash properly</p>	<p>Clean control and treat bed with Pro-Rust Out. Increase frequency of regeneration.</p> <p>Increase frequency of regeneration.</p> <p>Correct water supply problem.</p>
5. Loss of media through drain line	<p>Air in water system</p> <p>Backwash rate too fast</p>	<p>Assure that well system has proper air eliminator control. Check for dry well condition.</p> <p>Check drain flow control for proper flow rate.</p>
6. Drain flows continuously	<p>Foreign material in control</p> <p>Timer motor stopped or jammed</p>	<p>Remove piston assembly and inspect bore, remove foreign material and check control in various regeneration positions.</p> <p>Replace timer motor.</p>

# Guarantee

**Novatek** guarantees that your new water conditioner is built of quality material and workmanship. When properly installed and maintained, it will give years of trouble free service.

**Seven Year Complete Parts Guarantee:**

**Novatek** will replace any part which fails within 84 months from date of manufacture, as indicated by the serial number provided the failure is due to a defect in material or workmanship. The only exception shall be when proof of purchase or installation is provided and then the warranty period shall be from the date thereof.

**Lifetime Guarantee on Mineral Tanks and Brine Tanks:**

**Novatek** will provide a replacement mineral tank or brine tank to any original equipment purchaser in possession of a tank that fails within his/her lifetime, provided that the water conditioner is at all times operated in accordance with specifications and not subject to freezing.

**General Provisions:**

**Novatek** assumes no responsibility for consequential damage, labor or expense incurred as a result of a defect or for failure to meet the terms of these guarantees because of circumstances beyond its control.

# NOVATEK