

---

# **DUROsoft MX**

## **SENSOR INITIATED WATER SOFTENERS**

# ***Operation Manual***

***PLEASE NOTE: On Page 5 of this manual you will find important maintenance procedures for the continued proper operation of your unit. These MUST be performed regularly for your guarantee to remain valid.***

***Also note that this unit is equipped with a microprocessor. Please review all operating instructions before commencing installation.***

# **DURO**

---

## Performance

Item No.	Model No. Description	Capacity - Grains			Flow Rate USGPM	Resin Tank Size Inches	Brine Volume Gal/FT	Cabinet or Brine Tank Inches Width	Salt Capacity lbs	Shipping Weight lbs
		10 lbs per min	Factory setting 6 lbs per min	6 lbs per min						
3228*	DC20MX	23,250	17,625	12,525	8	9 x 35	.75	14 x 18 x 44*	240	90
3229*	DC30MX	31,000	23,500	16,700	10	10 x 35	1	14 x 18 x 44*	200	105
3223	DT20MX	23,250	17,625	12,525	8	9 x 35	.75	14 x 18 x 37	300	85
3224	DT30MX	31,000	23,500	16,700	10	10 x 35	1	14 x 18 x 37	300	100
3225	DT40MX	38,750	29,375	20,875	12	10 x 47	1.25	14 x 18 x 37	300	140
3226	DT60MX	62,000	47,000	33,400	12	12 x 52	2	22 x 38	400	190
3227	DT90MX	93,000	70,500	50,100	15	14 x 65	3	22 x 38	400	230

\* Cabinet Models

Changing salt settings from factory setting may require changing injector sizes to achieve stated capacities.

The manufacturer reserves the right to make product improvements which may deviate from the specifications and descriptions stated herein, without obligation to change previously manufactured products or to note the change.

## How Your DUROsoft MX Water Softener Works

Hard water enters your home through the main supply line, enters the softener and passes down through a resin mineral bed which softens the water. An ion exchange process takes place in which the resin beads capture and hold calcium and magnesium, the hardness impurities, while the water takes on sodium ions. The soft water then flows into your household water line.

The sensor control operates on the principle that the resin bed changes conductivity as it depletes. The sensor automatically checks the state of the resin bed in your softener 24 hours a day. When the sensor control determines the capacity of the resin bed is depleted, the resin is automatically regenerated by passing a brine solution through it. This reverses the ion exchange process, charging the resin with sodium and freeing the hardness minerals. These minerals and the brine solution are then flushed away through the drain line followed by a rapid rinse. The resin bed is again ready to soften water. The proper volume of water is returned to the brine tank to dissolve enough salt for the next recharge. All this is performed automatically.

## Installation Instructions

### CAUTION:

If the ground from the electrical panel or breaker box to the water meter or underground copper pipe is tied to the copper water lines and these lines are cut during installation of the Noryl bypass valve and/or poly pipe, an approved grounding strap must be used between the two lines that have been cut in order to maintain continuity. The length of the grounding strap will depend upon the number of units being installed and/or the amount of copper pipe being replaced with poly. See Figure 1.

In all cases where metal pipe was originally used and is later interrupted by poly pipe or the Noryl bypass valve as in Figure 1 or by physical separation as in Figure 2, to maintain proper metallic pipe bonding, an approved ground clamp c/w not less than #6 copper conductor must be used for continuity.

Check your local electrical code for the correct clamp and cable size.

1. Determine the best location for your water softener, bearing in mind the location of your water supply lines, drain line and 120 volt AC electrical outlet. Subjecting the softener to freezing or temperatures above 49°C (120°F) will void the warranty.

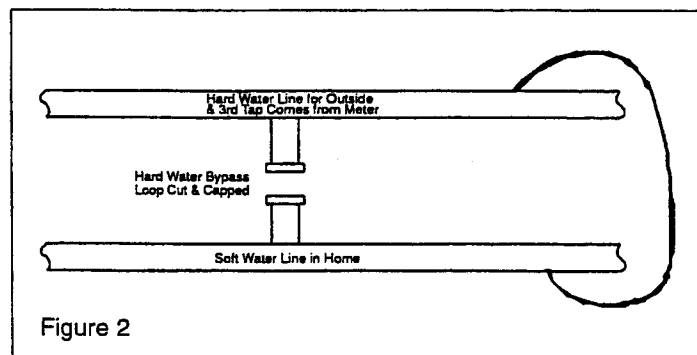
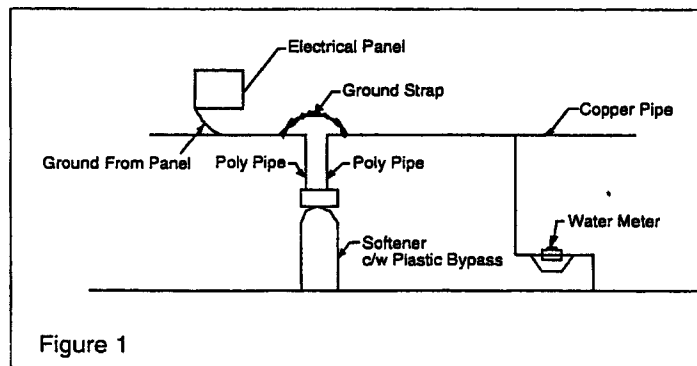

# Installation Instructions

- Water to supply outside faucets used to water lawns and gardens should not be softened. A new water line is often required to be connected to supply hard water to the inlet of the water softener and to the outside faucets. Cut the water line between where it enters the house; before any lines that branch off to feed the hot water heater or other fixtures in the house; and as near the desired location of the water softener as possible. Install a tee fitting on the feed end of the cut pipe and an elbow fitting on the other end. Install piping from the tee to the inlet of the water softener and from the elbow to the outlet to the softener. To sever the water lines which branch off to feed outside faucets, cut the branch lines approximately two inches from the fitting on the main water line. Install an elbow on the end of the pipe nearest the outside faucet and a cap on the end connected to the existing water line. Install piping from the tee on the inlet line to the water softener to the elbow on the pipe to the outside faucet. Following this procedure will result in all lines in the house, with the exception of the outside faucets but including the water heater and therefore the hot water lines, being supplied with soft water.

- On cabinet models, lift the cabinet hood to expose the control valve. The electronic control module in the cabinet hood remains connected to the control valve by means of the wiring harness. Familiarize yourself with the location of the inlet, outlet and drain on the control valve. Be very careful not to get the controls wet.
- Attach the bypass valve to the control valve. Connect the inlet and outlet of the water softener to the plumbing in the house. The control valve must not be subjected to temperatures above 71°C (160°F). To avoid damaging the control valve when sweat fittings are used, solder the threaded copper adapters to the copper pipe and then, using teflon tape, screw the assembly into the bypass valve.

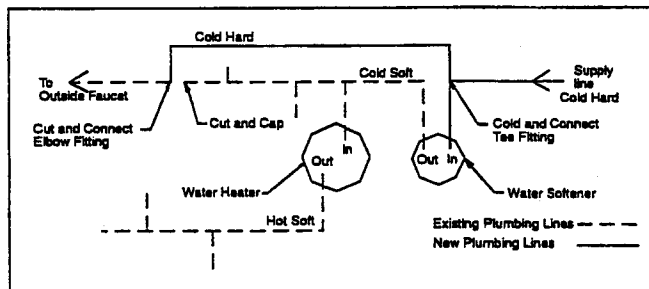

- CAUTION** - do not use pipe thread compound as it may attack the material in the valve body.
- Using teflon tape, screw the 1/2" hose barb into the drain port in the valve. Attach 1/2" drain hose to the hose barb and tighten securely with a hose clamp. Run the drain line to a floor drain or a laundry drain. Complete any necessary plumbing.
  - On twin tank units, pull the 3/8" brine line through the hole in the side of the brine tank. Connect the brine line to the fitting on the side of the valve using the nut and ferrule. Tighten snugly.
  - Make sure the bypass valve is in the service position.
  - On cabinet models, the manual advance knob is located on the top of the control valve. To expose the manual advance knob on twin tank models, remove the electronic control module by removing the two screws which are inset on the sides of the electronic control module. **Do not plug the unit into an electrical outlet.** If the unit has been inadvertently plugged in, unplug the unit. The various regeneration positions may be dialed manually by turning the manual advance knob clockwise. Turn the knob clockwise to the backwash position. Slowly turn on the water supply and wait until the air clears. Allow the water to run to the drain for 2 to 3 minutes or until the water is clear. If air is trapped in the system it can cause the probe to send misinformation to the microprocessor, resulting in an error code "E1" being displayed and/or the unit malfunctioning when it is put into service. If this occurs repeat Step 8.
  - Turn the knob to the brine fill position and let water enter the brine tank to reach a height of 6" or approximately 2" above the grid in a model with a grid system. You can decrease the length of time required for this process by pouring water into the brine tank at the same time it is filling. However, it is necessary for the unit to be in the brine fill position for at least 2 minutes to purge any air from the pressure regulator and injector system. Trapped air can cause the system to malfunction during the first regeneration after start up.
  - Advance the knob through the soft water and backwash positions to the rinse position and determine that water is being drawn from the brine tank.
  - Advance the knob to the rapid rinse position and allow the water to run to drain for 2 minutes.
  - Turn the knob to the brine fill position until water reaches a level of 6" in the brine tank or is approximately 2" above the grid in models with a grid system. Index the control to the soft water position.
  - Plug the 24 volt transformer into a live 120 VAC 60 Hz outlet. The "power" light and display will come on. Wait 30 seconds, then set the hours by pressing and holding the "hours" keypad, then set the minutes by pressing and holding the "minutes" keypad (see detailed instructions on page 3, Figure 2). If you inadvertently press the "hours" keypad within 15 seconds, the unit will go into a diagnostic mode indicated by the word "OFF" being displayed. To exit the diagnostic mode and reset the unit, unplug the unit from the electrical outlet and plug it back in. Wait 30 seconds and set the hours and minutes as described above.
  - The softener is shipped with the 9 volt alkaline battery disconnected. Connect the battery which is located under the control module on twin tank models or at the rear of the electronic control module on cabinet models. The display will show "LO BAT" on the left hand side of the display if the battery is weak or is disconnected.
  - Before replacing the control valve cover and salt cover on cabinet models or Electronic Control Module on twin tank models, ensure the wiring harness is securely plugged into the circuit in the electronic control module. The unit is in the sensing mode and will regenerate automatically as needed.
  - Put a minimum of 40 kg of crystal water softener salt in the brine tank. The unit will automatically fill to the correct level when it regenerates.
  - Check the display lights on the face of the timer, only the "power" light should be on. If another light is on see Page 3 - Indicator Lights (LED's).
  - Check that the correct time of day is displayed. If the time of day is incorrect, see page 3. If an error code is displayed (E1, E2 or E3) see Page 3 - Display Codes.

**ALL GOVERNMENT CODES GOVERNING INSTALLATIONS OF THESE DEVICES MUST BE OBSERVED.**

# Operating Instructions

## Indicator Lights (LEDs)

### Power

This light will be on whenever the softener transformer is plugged into a 120 VAC outlet and power is being supplied.

### Regen

This light will begin to flash for a five minute period when a regeneration cycle begins. It will emit a steady light for the remaining 150 minutes of the regeneration cycle.

### No Brine

This light will begin to flash when the softener is regenerated with insufficient salt brine solution. After correcting the situation (ie. adding salt) and manually regenerating the softener with the proper brine solution, the light will go off.

### Display Codes (Figure 1)

- E 1 This code will be displayed if the probe is disconnected or a probe wire is broken or excess air remains in the tank.
- E 2 This code will be displayed if the regeneration cycle is not completed within 4 hours after regeneration is initiated.
- E 3 This code will be displayed if the control valve has not advanced out of home position within 25 minutes from the start of the regeneration cycle.

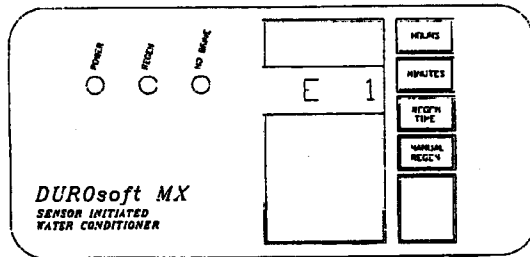

Figure 1

**Note:** The softener may need to be serviced by a qualified service technician because the display codes are the result of a mechanical or electrical problem that will cause the softener to malfunction. Once a problem is detected, the code is displayed and circuit stops functioning. To restore normal operation, correct the mechanical or electrical problem first, then reset the circuit. To accomplish this, unplug the 24 volt transformer and plug it in again. Finally the softener needs to be manually regenerated.

## Setting the Time of Day

(Figure 2)

To set the correct time, press the "hours" keypad until the correct hour is displayed and release. Then press the "minutes" keypad until the correct minute is displayed and release. Please note, the time of day must be set for a.m. or p.m. as appropriate. A dot below the colon separating the hours and minutes on the display indicates p.m. The dot's absence indicates a.m.

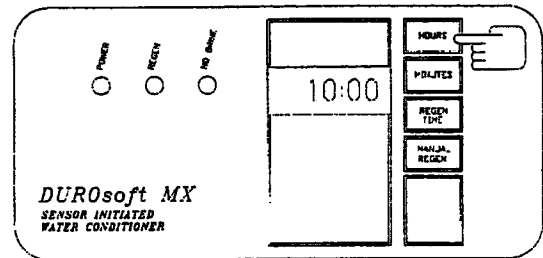

Figure 2

## Setting the Time of Regeneration

(Figure 3)

All DUROsoft MX water softeners are factory set to regenerate at 2:00 a.m. To change this setting, press and hold the "regen time" keypad. The display will show the previously set time of regeneration and the colon, which separates the hours and minutes, will be on steady indicating you are setting the time of regeneration. The regeneration time may now be reset to the time you wish by simply pressing the "hours" keypad and then the "minutes" keypad while simultaneously pressing the "regen time" keypad. Please note, the time of regeneration must be set for a.m. or p.m. as appropriate. A dot below the colon separating the hours and minutes on the display, indicates p.m. The dot's absence indicates a.m.

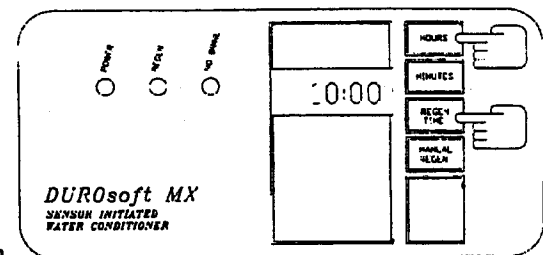

Figure 3

## Manually Initiated Regeneration

(Figure 4)

Sometimes you may run out of soft water because of extra high water usage or lack of salt in your softener. Should this happen or be anticipated, you can initiate an immediate manual regeneration by simply pressing and releasing the "manual regen" keypad. The red "regen" indicator will begin to flash. Be sure there is salt in the brine tank and sufficient salt brine solution. If possible, avoid using soft water during the regeneration cycle.

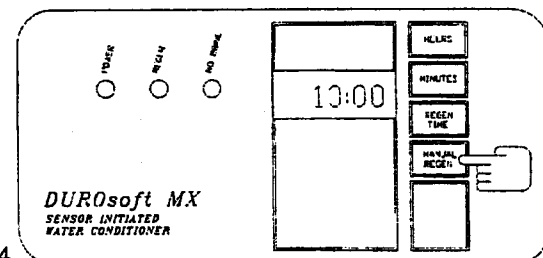

Figure 4

## Salt Settings are factory set and should not need adjustment

DC20MX & DT20MX	.5 lbs
DC30MX & DT30MX	.6 lbs
DT40MX	.8 lbs
DT60MX	.6 lbs (represents 12 lbs)
DT90MX	.9 lbs (represents 18 lbs)

## Automatic Bypass

The regeneration cycle lasts approximately 2½ hours, after which soft water service will be restored. During regeneration, hard water is automatically bypassed for use in the household. Hot water should be used as little as possible during this time to prevent hard water from filling the water heater. This is why automatic regeneration is set for sometime during the night and manual regenerations should be performed when little or no water will be used in the household.

## Safety Float

The brine tank is equipped with a safety float which prevents your brine tank from overflowing as a result of a malfunction such as a power failure.

## Water Pressure

Your softener is designed to operate under normal water pressures from 20 psi (1.4 atm) to 120 psi (8.2 atm).

## New Sounds

You may notice new sounds as your water softener operates. The regeneration cycle lasts approximately 2½ hours. During this time, you may hear water running intermittently to the drain.

## Manual Bypass (Figure 5)

In the case of an emergency, such as an overflowing brine tank, you can isolate your water softener from the water supply using the bypass valve located at the back of the control.

In normal operation the bypass is open with the on/off knobs in line with the inlet and outlet pipes. To isolate the softener, simply rotate the knobs clockwise (as indicated by the word BYPASS and arrow) until they lock.

You can use your water related fixtures and appliances as the water supply is bypassing the softener. However, the water you use will be hard.

To resume soft water service, open the bypass valve by rotating the knobs counter-clockwise.

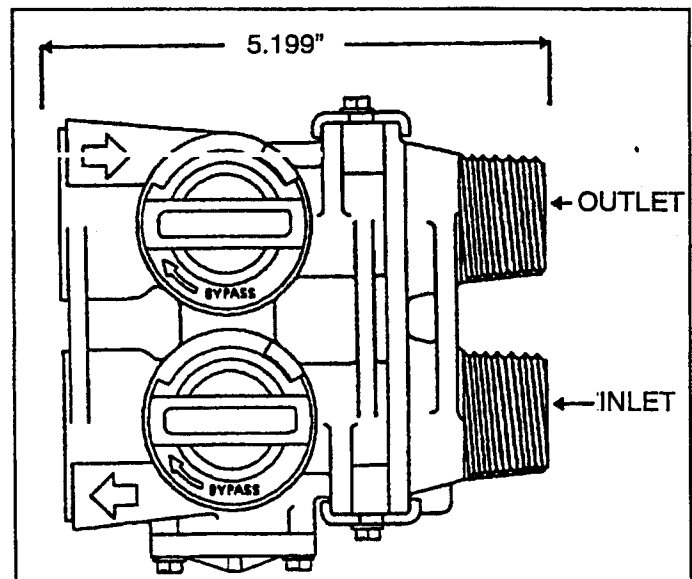

Figure 5

# Maintenance

## Adding Salt

Use only crystal water softener salt. Check the salt level monthly. It is important to maintain the salt level above the water level. To add salt, simply lift the salt lid and add the salt directly into the brine tank. Be sure the brine well cover is on and fill only to the height of the brine well.

## Bridging (Figure 6)

Humidity or wrong type of salt may create a cavity between the water and the salt. This action, known as "bridging", prevents the brine solution from being made, leading to your water supply being hard.

If you suspect salt bridging, carefully pound on the outside of the brine tank or pour some warm water over the salt to break up the bridge. This should always be followed up by allowing the unit to use up any remaining salt and then thoroughly cleaning out the brine tank.

Allow four hours to produce a brine solution, then manually regenerate the softener.

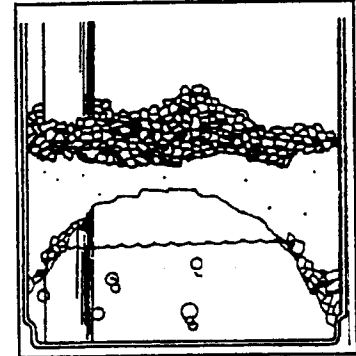

Figure 6

## Care of Your Softener

To retain the attractive appearance of your new water softener, clean occasionally with mild soap solution. Do not use abrasive cleaners, ammonia or solvents. Never subject your softener to freezing or to temperatures above 120°F.

## Cleaning the Injector Assembly (Figure 7)

Sediment, salt and silt will restrict or clog the injector. A clean water supply and pure salt will prevent this from happening.

The injector assembly is located on the left side of the control valve. This assembly is easy to clean.

Shut off the water supply to your softener and reduce the pressure by opening a cold soft water faucet. Using a screwdriver, remove the two screws holding the injector cover to the control valve body. Carefully remove the assembly and disassemble as shown in Figure 7. The injector orifice is removed from the valve body by carefully turning it out with a large screwdriver. Remove the injector throat the same way. Carefully flush all parts including the screen. Use a mild acid such as vinegar or Pro-Rust Out to clean the small holes in the orifice and throat.

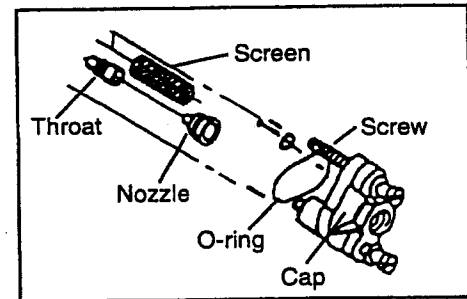

Figure 7

Reassemble using the reverse procedure.

NOTE: The injector cover contains a factory set pressure regulator. Do not attempt to adjust this regulator.

## Resin Cleaner

An approved resin cleaner **must** be used on a regular basis if your water supply contains iron. The amount of resin cleaner and frequency of use is determined by the quantity of iron in your water (consult your local representative or follow the directions on the resin cleaner package).

## Battery Back-up

DUROsoft MX utilizes a 9 volt alkaline battery to maintain the time functions only. In the event of a power outage, the LCD display and LED indicator lights will go out. When power is restored, the "power" light and LCD display will come on again with the correct time of day and time of regeneration. The sensor functions are saved in special non-volatile memory and can be retained for years without power. When power is restored, sensor conditions will be restored to the same state as before the power outage occurred.

If a power failure occurs just prior to the initiation of a regeneration, the regeneration will not take place until power is restored and the next regeneration time is reached.

Locate the battery under the electronic control module on twin tank models or at the rear of the electronic control module on cabinet models. The battery has a shelf life of approximately one year. It should be replaced each year or when the display shows "LO BAT" on the left hand side, indicating the battery is weak or disconnected. Simply disconnect the battery and replace with a new 9 volt alkaline battery. If the old battery is dead, it will be necessary to reset the time of day and regeneration and to perform a manual regeneration.

# Trouble Shooting Guide

Before calling for service, follow the steps below, then MANUALLY REGENERATE your softener.

PROBLEM	CAUSE	CORRECTION
1. Softener delivers hard water	Bypass valve is open	Close bypass valve.
	No salt in brine tank	Add salt to brine tank and maintain salt level above water level.
	Insufficient water flowing into brine tank	Check salt setting and clean brine line flow control if plugged.
	Salt bridged	Break salt bridging – see page 5.
	Loose brine line	Tighten connections at control valve and at brine valve.
	Plugged injector assembly	Clean/replace injectors and screen.
	Printed circuit board is defective	Replace circuit board.
2. Intermittent soft water	Control will not draw brine properly	Maintain water pressure at 20 psi minimum. Check for restrictions in drain line. Clean or replace injector assembly. Check for air leaks between control valve and air check valve and tighten connections.
	Using hot water during regeneration cycle	Avoid using hot water at this time as water heater will fill with hard water.
	Incorrect salt setting	Adjust salt setting
	Softener capacity too small	Increase capacity by replacing with larger unit.
3. Softener regenerates at wrong time	Timer is defective	Replace printed circuit board.
	Power failure or incorrect setting	Restore power and reset time of day.
4. Unit uses too much salt	Improper salt setting	Check salt usage and salt setting.
	Excessive water in brine tank	Remove water. Clean drain line flow control, brine line flow control, injector system, and brine valve.
5. Loss of water pressure	Inlet to control blocked with iron buildup or foreign matter	Clean line to water softener. Remove piston and clean control.
	Iron buildup in water conditioner	Clean control and add resin cleaner to resin bed.
6. Iron in conditioned water	Fouled resin bed	Check backwash, brine draw and brine tank fill. Clean control and add resin cleaner to resin bed.
7. Softener fails to draw brine	Drain line flow control is plugged	Clean drain line flow control.
	Brine line flow control is plugged	Clean brine line flow control.
	Faulty pressure regulator	Replace injector cover.
	Injector assembly is plugged	Clean/replace injectors and screen.
	Line pressure is too low	Increase line pressure. Line pressure must be at least 20 psi (139.9 KPa) at all times.
	Internal control leak	Change seals and spacers and/or piston assembly.
8. Drain flows continuously	Foreign material in control	Remove piston assembly and inspect bore, remove foreign material and check control in various regeneration positions.
	Internal control leak	Replace seals and/or piston assembly.
	Control valve is jammed in brine or backwash position	Replace piston and seals and spacers.
	Drive motor stopped or jammed	Replace drive motor.
9. Softener fails to regenerate	No salt in brine tank	Add salt.
	Injector assembly plugged	Clean/replace injectors and screen.
	Salt bridged	Break salt bridging – see page 5.
	Insufficient salt used per regeneration	Check and adjust salt setting.
	Softener capacity too small	Replace softener with larger unit.
	Defective control	Replace printed circuit board.
10. Softener regenerates every night	Softener capacity too small	Replace with larger unit.
	Printed circuit board is defective	Replace circuit board.

# Guarantee

**WaterGroup Companies Inc.** guarantees that your new water conditioner is built of quality material and workmanship. When properly installed and maintained, it will give years of trouble free service.

**Five Year Complete Parts Guarantee:**

**WaterGroup Companies Inc.** will replace any part which fails within 60 months from date of installation provided the failure is due to a defect in material or workmanship.

**Lifetime Guarantee on Mineral Tanks and Brine Tanks:**

**WaterGroup Companies Inc.** will provide a replacement mineral tank or brine tank to any original equipment purchaser in possession of a tank that fails within his/her lifetime, provided that the water conditioner is at all times operated in accordance with specifications and not subject to freezing.

**General Provisions:**

**WaterGroup Companies Inc.** assumes no responsibility for consequential damage, labor or expense incurred as a result of a defect or for failure to meet the terms of these guarantees because of circumstances beyond its control.

## WaterGroup

580 Park Street, Regina, Saskatchewan S4N 5A9  
265 Industrial Road, Cambridge, Ontario N3H 4R9

**WATERGROUP COMPANIES INC.**

580 Park Street  
Regina, SK S4N 5A9  
[www.watergroup.com](http://www.watergroup.com)

265 Industrial Road  
Cambridge, ON N3H 4R9

51631 Rev98/07  
Printed in Canada