

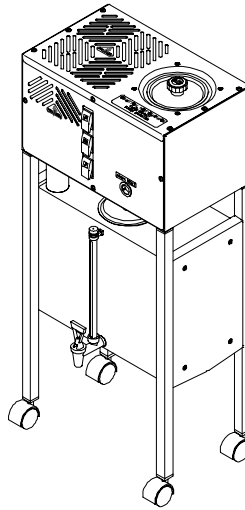

Precision Water Distillers Owners' Guide



Model: PWS 12-12

Part No. 510000

Series: 0013

Manufactured By:
Precision Design & Manufacturing Inc.
10331-105 Street,
Westlock, AB, Canada
T7P 2H7
<http://www.precisioncanada.com>
e-mail: info@precisioncanada.com
Phone: (780) 349 4933
FAX: (780) 349 4957

Please read this Owners' Guide completely before installing or operating your Precision Water Distiller.

Specifications are subject to change without notice.

Part No. 097123-

Series: 0013

Printed in Canada

06-24-2003

Copyright © 2003

This page left intentionally blank

Table of Contents

TABLE OF CONTENTS	3
INTRODUCTION	4
RECORDS	5
PRECISION WATER DISTILLER WARRANTY.....	6
IMPORTANT SAFETY PRECAUTIONS.....	7
ADDITIONAL SAFETY RECOMMENDATIONS.....	7
PRECISION WATER DISTILLER OWNERS' SUMMARY	8
WATER DISTILLER FEATURES.....	9
10 FACTORS THAT WILL AFFECT YOU WATER DISTILLER PRODUCTION.....	10
UNDERSTANDING HOW PURE WATER IS PRODUCED	13
FINDING A GOOD INSTALLATION LOCATION.....	14
UNPACKING YOUR WATER DISTILLER	15
WATER DISTILLER INSTALLATION TOOLS.....	17
STORAGE TANK ASSEMBLY	18
MANUAL DRAIN VALVE TUBE INSTALLATION.....	21
FEED WATER LINE CONNECTION	22
BOILING TANK LID INSTALLATION	25
STORAGE TANK LID REMOVAL AND INSTALLATION.....	25
WATER DISTILLER WALL STABILIZER.....	26
OPERATION	27
CONTROLS - POWER, FAN, WATER, OVERHEAT RESET AND FUSE.....	27
STORAGE TANK DRAIN VALVE.....	29
BEFORE INITIAL WATER DISTILLER OPERATION	30
NORMAL OPERATION.....	31
MAINTENANCE AND CLEANING.....	32
REGULAR INSPECTION AND CLEANING OF BOILING TANK.....	32
CLEANING THE BOILING TANK USING CLEANER DESCALER.....	33
REPLACING CHARCOAL IN CHARCOAL FILTER CANISTER.....	35
STERILIZATION	36
Liquid Sterilization of Storage Tank and Optional Pump Water Line System.....	36
Steam Sterilization of Water Distiller Head	37
Steam Sterilization of Water Distiller Head, Filter Canister and Storage Tank	39
Maintenance Schedule Table	41
Owner Maintenance Record Table	41
TROUBLESHOOTING.....	42
OPTIONAL ACCESSORIES	47
PWS APK-1 PUMP KIT.....	47
PWS APK-1 PUMP KIT INSTALLATION.....	48
PWS AED-1 AUTOMATIC ELECTRIC DRAIN KIT INSTALLATION	55
ADDITIONAL OPTIONS.....	59
Sediment Pre-Fitler Assembly, Charcoal Post-Filter Assembly, Pressure Accumulator, Water Distiller Cleaner and Descaler, Pure Activated Coconut Charcoal for Refillable Charcoal Filter Canisters and Tee Valve.....	59
SPECIFICATIONS AND TECHNICAL INFORMATION.....	61
WIRING LIST AND SCHEMATIC	ERROR! BOOKMARK NOT DEFINED.
INDEX	64
WARRANTY REGISTRATION CARD	65

Introduction

Congratulations on the purchase of the most advanced water distiller in the industry! When installed and maintained properly, your Precision Water Distiller will provide years of safe, trouble free service. It is important to observe and follow the safety and maintenance instructions carefully. If you have any questions or concerns regarding installation or operation of your water distiller, please contact your dealer.

All 120 VAC Precision Water Distillers are certified to cCSAus Classes 2831-02 and 2831-82 under the Canadian and American Electrical Code.

All water distillers are factory tested with a high voltage 'Dielectric Strength Test' and ground fault test prior to shipping.

Precision Water Distillers have been tested by EnviroTest Laboratories which found the water distillation units to be very effective water treatment systems capable of removing both harmful pathogens and toxic chemicals from water. In their study all pathogens were eliminated and none were found in the distilled water. The water distillation system also effectively removed all of the soluble inorganic chemicals tested. Removal efficiencies of 99% or greater were achieved for almost every chemical tested.

All Precision Water Distillers are operated and tested at the factory and have produced distilled water to make sure all components are functioning properly. All water distillers are wiped clean before shipping, but there may be a water ring inside the boiling tank. There may also be an off-colour line at the seams of the storage and boiler tank. This is caused by the TIG welding process used during manufacturing. This is normal and is not a sign of a problem. Follow all the **Before Initial Water Distiller Operation** procedures and you will have pure water in no time.

Your Precision Water Distiller must be installed according to any Local, State or Provincial Regulations.

Records

Please record all of the important information below to assist you and the service center in case there is any service work required in the future. All of the information is required to properly identify your water distiller and will make servicing much easier. The information is located on the serial plate on the side of the water distiller head. The **Serial Plate Location Diagram** below shows a sample serial plate.

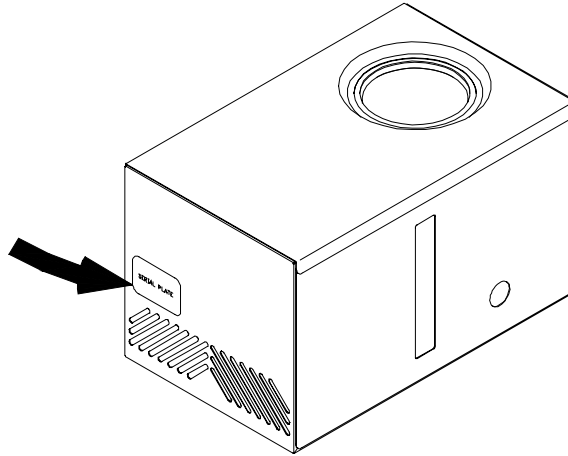

Serial Plate Location Diagram

Model: PWS 12-12

Series: *eg: 0013*

Serial Number: *eg: 0123012*

Date of Purchase: _____

Dealer Purchased From: _____

Optional Pump Serial No: _____

Series: _____

Optional Drain Serial No: _____

Series: _____

Precision Water Distiller Warranty

- The warranty for your Precision Water Distiller covers defects in materials for two (2) years on all parts and labor to the original purchaser.
- Stainless Steel parts are covered by a 15 year pro rated warranty. This covers all stainless steel parts such as the boiling and storage tank. With this warranty it is the responsibility of the distiller owner to properly maintain the distiller. If there is any misuse or abuse the lifetime warranty will be void.
- Precision Water Systems does not warrant any transportation charges incurred to complete the repair. The distiller owner is responsible for all shipping charges to and from the service center.
- Warranty is void if the distiller is found to have been consumer damaged or misused, caused by acts of God, unauthorized alteration, repair or vandalism.

Important Safety Precautions

When using electrical appliances, basic safety precautions should always be followed including the following:

- 1. Read all instructions.**
- 2.** Do not touch hot surfaces. Use handles or knobs.
- 3.** To protect against electrical shock do not immerse cords or plugs in water or other liquid.
- 4.** Close supervision is necessary when any appliance is used near children.
- 5.** Do not allow children to operate this appliance.
- 6.** Unplug from outlet when not in use and before cleaning. Allow to cool before putting on or taking off parts.
- 7.** Do not operate any appliance with a damaged cord or plug or after the appliance malfunctions or has been damaged in any manner. Return appliance to the nearest service facility for examination, repair or adjustment.
- 8.** The use of accessory attachments not recommended by the appliance manufacturer may cause injuries.
- 9.** Do not use outdoors.
- 10.** Do not let cord hang over edge of table counter, or touch hot surfaces.
- 11.** Do not place on or near a hot gas or electric burner, or in a heated oven.
- 12.** Extreme caution must be used when moving an appliance containing hot water.
- 13.** Always attach plug to appliance first, then plug cord into the wall outlet. To disconnect, turn any controls to "off", then remove plug from wall outlet.
- 14. This appliance is intended for household use.**
- 15. Save these instructions.**

Additional Safety Recommendations

- 1.** Always unplug appliance before servicing.
- 2.** Do not use extension cords with appliance.
- 3.** Ensure there is adequate air space around the appliance to allow the heat from the appliance to be removed and supply adequate fresh air for cooling.

Precision Water Distiller Owners' Summary

The following is a summary of the information contained in this Owners' Guide and required to install and operate your Water Distiller

- 1) Find a good location for installing your Water Distiller – See **Finding a Good Installation Location**.
- 2) Unpack the water distiller and parts - See **Unpacking Your Water Distiller**.
- 3) Assemble the Water Distiller – See
Storage Tank Assembly
Manual Drain Valve Tube Installation
Feed Water Line Connection
Boiling Tank Lid Installation
Water Distiller Wall Stabilizer
- 4) Install all purchased Options - See **Optional Accessories** for installation instructions.
- 5) Steam sterilize boiling tank and storage tank – See **Steam Sterilization** in the **Maintenance and Cleaning** section.
- 6) Load Charcoal Filter Canister – See **Replacing Charcoal in Charcoal Filter Canister** in the **Maintenance and Cleaning** section.
- 7) Follow procedure in **Normal Operation** section.
- 8) Enjoy pure, distilled water!

Water Distiller Features

Water Distiller Front View

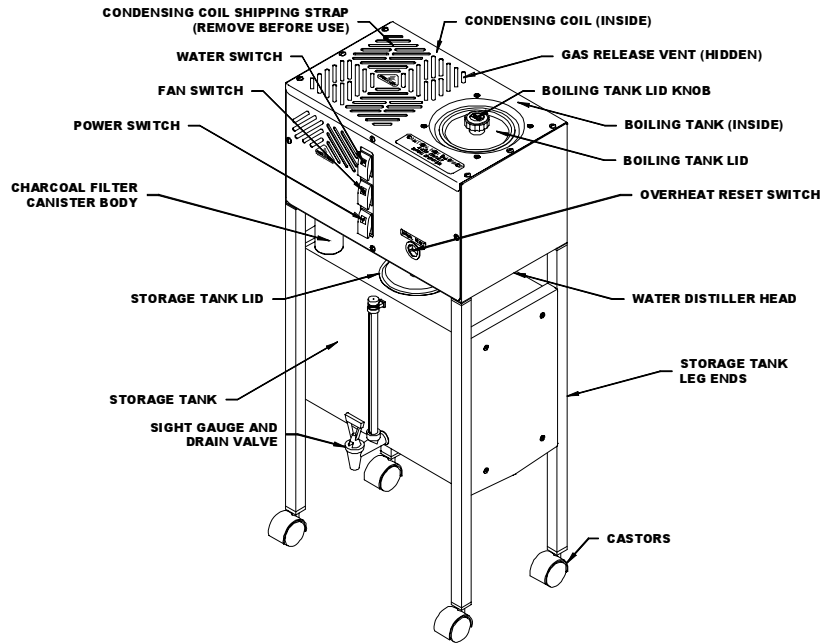

Water Distiller Rear View

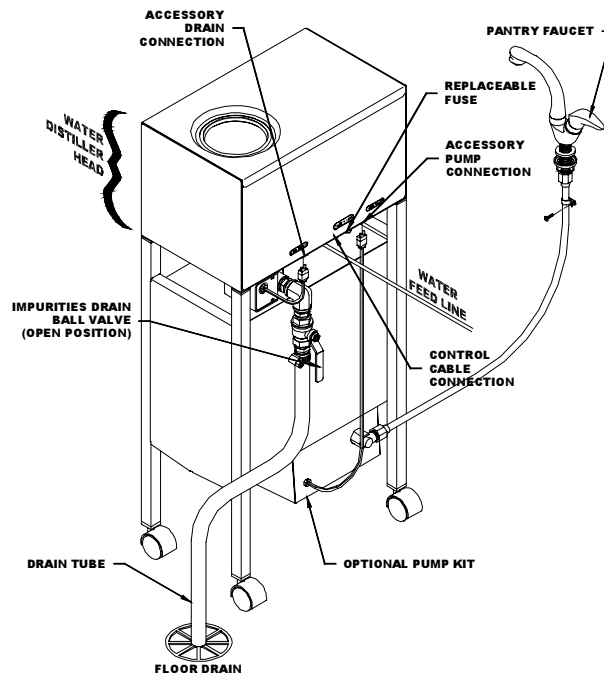

10 Factors That Will Affect Your Water Distiller Production

1. Water Volume Measurement

a) How are you measuring your water? The most accurate is by weight.
1 litre of pure water = 1 kg = 1000 g = 2.2046 lbs

b) Water distillers are rated in US gallons, NOT Imperial Gallons.
1 US Gallon = 3.785 litres = 3.785 kg = 8.344 lbs = 0.833 Imp. Gallons

c) Most distilled water holding tanks do not completely drain from the tap. Ensure this volume of water is included in your calculation by completely draining the tank or starting your production check with this volume pre-filled.

2. Line Voltage

The line voltage at the outlet where the distiller is connected should be checked with a voltmeter. Line voltage is often much less than expected, especially in rural areas. Line voltage will also usually drop off dramatically when the daily commercial load hits the grid from approximately 8 am to 5 pm (often when the distiller owner is not home and unable to check the line voltage). Line voltage lower than the distiller rated voltage (on the serial plate) will drastically lower the water production.

3. Fill Water Temperature

The water used to fill the machine may affect the water production. Cooler fill water will take more time/energy to heat to the boiling point than hot water.

4. Ambient Air Temperature

Water distillers with cooling fans must have sufficient ventilation so that the boiled steam can be cooled and condensed into distilled water. Restriction of air flow (such as a closed cupboard) will result in a hot ambient air build up which will not allow all of the steam to condense into distilled water and some water production may escape as steam into the atmosphere through the charcoal filter or volatile gas release vent. This steam loss can also occur in hot summer periods or very warm climates.

5. Heating Element and Boiler Cleanliness

As the water distiller removes impurities some of the impurities may cling to the boiler tank and the heating element. Any of this scale may build up around the heating element and actually insulate it, which will drastically decrease the thermal efficiency of the heating element and require more time/energy to boil water, which will decrease the water production.

6. Altitude

The water distiller is rated at the altitude of the manufacturer, which is approximately 675 m (2214 ft) above sea level. Locations lower than this (closer to sea level) will have reduced water production due to the higher boiling point of water at higher atmospheric pressures at lower altitudes.

7. Operating Time, Warm-up Period & Suitable Storage

When checking the water distiller production, the start time should be when the first few drops of water have entered the charcoal filter canister. Do not start timing when the distiller turns on as it takes a few minutes for the heating element, boiler tank and water to heat up. The distiller production rating does NOT account for this time, but rather the continuous production after the distiller is up to temperature. Ensure when checking production that you have suitable water storage for holding the amount of water that will be produced.

8. Manual Fill Boiling Tank Fill Level

When checking the water distillation production on manual fill water distillers, the amount of water initially poured into the boiling tank will affect the production. Water should be filled to the water level pin so that once the water is hot the maximum amount of water can be distilled without having to heat up and refill. Under-filling the boiler will decrease the amount of water distilled. Again, the warm-up time should not be included in the production rate.

9. Boiling Tank Heating Element

Once all other factors have been eliminated or checked, have an authorized service center check that the proper heating element has been installed in your distiller. Always replace heating elements with the manufacturers supplied heating elements. Other elements are available from hardware stores, home repair centers, etc. and look like the same element but they are almost always not the same. Even if the voltage and wattage are the same, they usually have different wattage densities and most likely different element sheath materials, which will result in premature heater burnout in continuous water distillation of raw water. These heating elements will also likely affect your water distillation capacity.

10. Combination of the above Factors.

Often a reduced water distiller's production is a combination of many or all of the above factors. To ensure maximum production from your water distiller, keep your water distiller clean and operate it in a well-ventilated area and use room temperature feed water where possible.

Understanding How Pure Water is Produced

Your water distiller operates the same as Nature's hydrological cycle. See the **Hydrological Cycle Diagram** below. Nature uses the heat of the sun to vaporize surface water and draw it into the atmosphere leaving the impurities behind. As the vapour cools it condenses and returns back to the earth as rain or snow. When rain or snow falls it passes through smog, dust and many other types of contaminants. These contaminants can be picked up by the falling rain or snow. Additional contamination of water can occur when it moves through the ground.

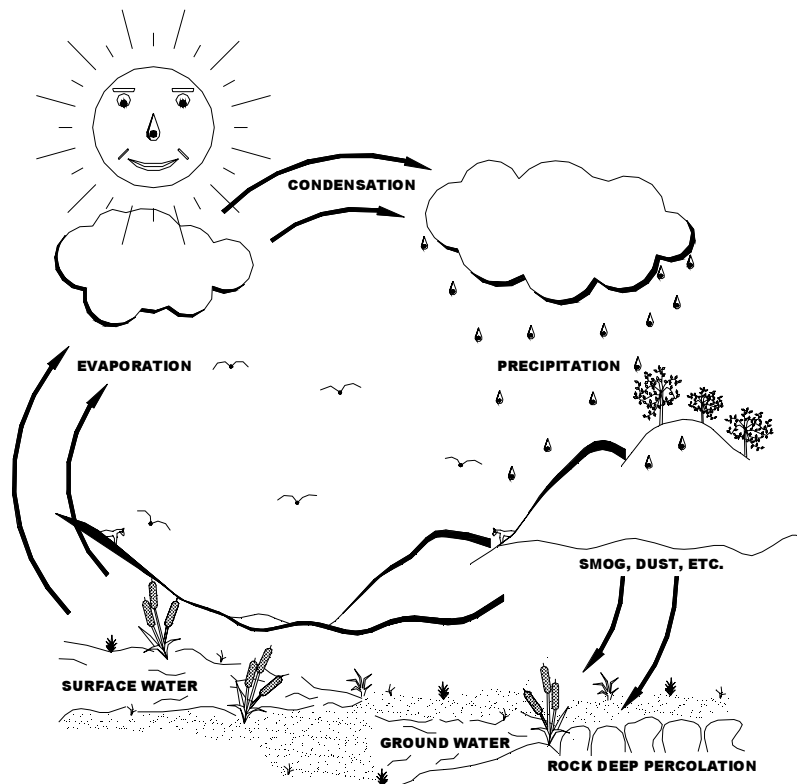

Hydrological Cycle Diagram

Water Distillers complete their own hydrological cycle. The advantage of a water distiller over Nature is that the water is produced in a closed environment free of pollution and contaminants.

Your water distiller uses the boiling tank to heat the feed water to create steam. The steam rises from the boiling tank leaving almost all of the impurities behind. The steam enters the condensing coil and is cooled by the fan. As the steam cools it condenses into pure distilled water and is stored in a stainless steel storage tank. The charcoal filter between the condensing coil and storage tank and the volatile gas vent remove any contaminants that boil at lower temperatures than the boiling point of water. The impurities from the process remain in the boiling tank and are drained to a suitable drain.

Finding a Good Installation Location

Before installing your water distiller it is important to find a good location. Following the points listed below will provide the best location for your water distiller:

- 1.** The water distiller must be plugged directly into a dedicated 120VAC, 15 Amp wall outlet.
- 2.** The water distiller requires sufficient airflow around it to operate. The air is used to cool the water distiller condensing coil. Locate the water distiller in an area that will provide enough room for good air flow. Do not place the water distiller in an enclosed area like a closet.
- 3.** When using the Automatic Feed Water Line Connection to the water distiller, locate the water distiller close to a household cold water line (after a water softener if available).
- 4.** Locate the water distiller where a pail or suitable container can be used for the impurities drain. Close to a floor drain (sewer) is best especially if the Automatic Drain Kit is installed.
- 5.** When unpacking the water distiller and options note the sizes and consider this when picking an installation location.
- 6.** Locate the water distiller away from a bedroom or other area where the noise of the water distiller may be undesirable.
- 7.** Locate the water distiller close to the kitchen faucet area if the automatic pump option is being used.
- 8.** Locate the water distiller in an area that is clean and free of dust so the cooling coils remain clean when the fan is drawing fresh air.

Unpacking Your Water Distiller

Your Water distiller has been shipped in one box. Any optional accessories have been shipped in a separate box(s). The **Water Distiller Box Components Diagram** shown as follows displays all of the parts that will be in the water distiller box.

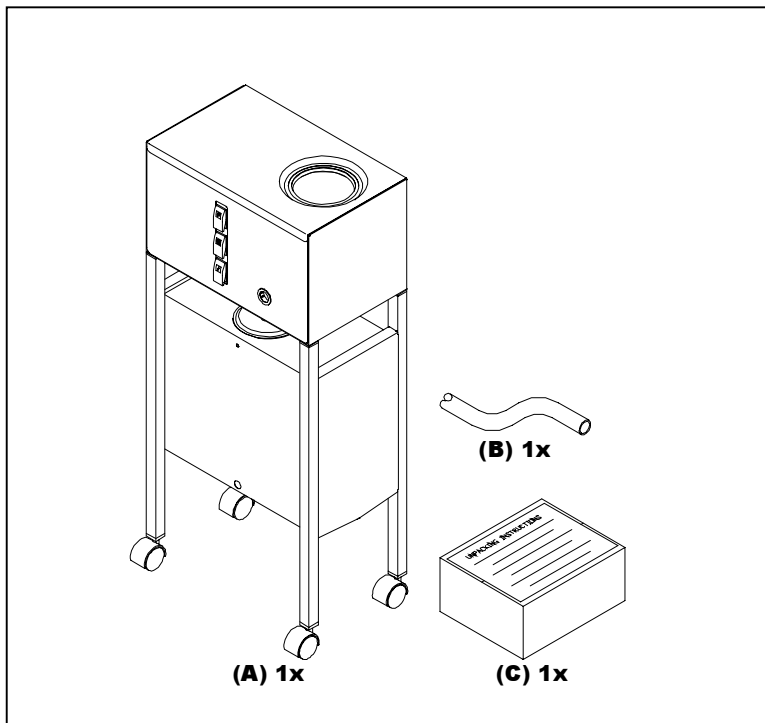

Water Distiller Box Components Diagram

Water Distiller Box Check List

Check
List

- (A) 1 – PWS 12-12 Water Distiller Head and Storage Tank
- (B) 4' – 1" x 1 ¼" Drain Tube
- (C) 1 – Parts Box with UNPACKING INSTRUCTIONS
(**Water Distiller Parts Box Components Diagram** shown as follows)

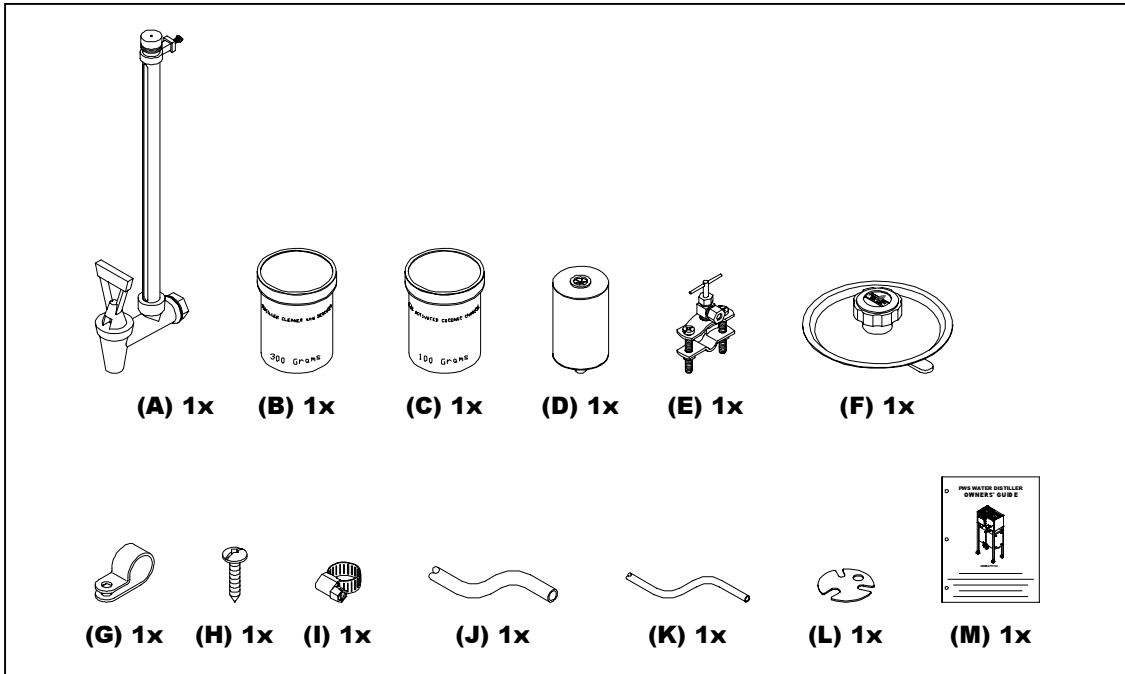

Water Distiller Parts Box Components Diagram

Water Distiller Parts Box Check List

Check

List	Part No.	
<input type="checkbox"/> (A)	080122	1 – Sight Gauge and Valve, HT, 13”
<input type="checkbox"/> (B)	080115	1 – Sample Descaler/Cleaner
<input type="checkbox"/> (C)	080116	1 – Sample Coconut Charcoal
<input type="checkbox"/> (D)	500306	1 – Stainless Steel Canister
<input type="checkbox"/> (E)	036005	1 – Valve Kit, Self Piercing
<input type="checkbox"/> (F)	500184	1 – Boiling Tank Lid
<input type="checkbox"/> (G)	054020	1 – 1 ¼” Distiller Support Clip
<input type="checkbox"/> (H)	010008	1 – No. 10 x 1” Screw
<input type="checkbox"/> (I)	080121	1 – 1 ¼” Gear Clamp
<input type="checkbox"/> (J)	052002	2’ – Sterilization Drip Tube
<input type="checkbox"/> (K)	052000	16’– ¼” Feed Line
<input type="checkbox"/> (L)	500282	1 – JG Removal Tool
<input type="checkbox"/> (M)	097123	1 – PWS 12-12 Owners Guide

- 1.** Remove all loose pieces from the water distiller box and save all packaging until all the parts are identified and located.
- 2.** Check inside boiler tank and storage tank for any parts that may be shipped in that area. If any parts are missing or if you feel you have been given the wrong part, DO NOT return the water distiller unit. Contact your dealer for the required parts. They will be pleased to assist you.
- 3.** Remove all protective plastic from water distiller head, storage tank, boiling tank lid and storage tank lid.

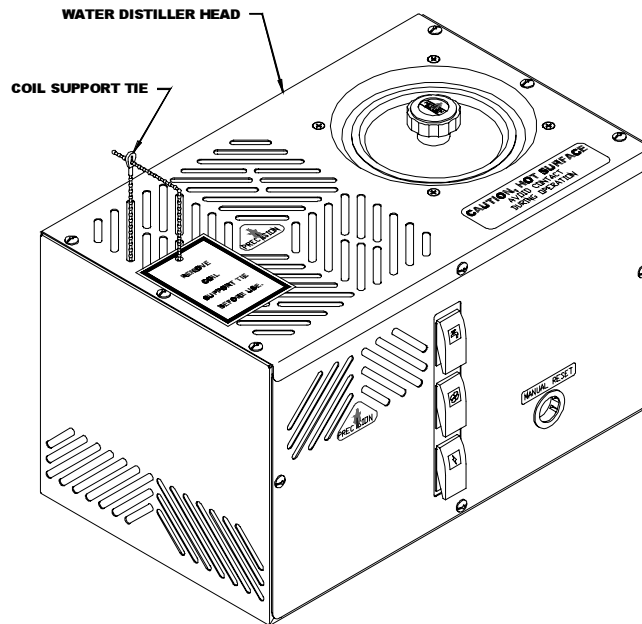

Shipping Tie Removal Diagram

4. Refer to **Shipping Tie Removal Diagram** above. Cut/Remove the shipping tie located on the top of the water distiller head. Be careful not to scratch the water distiller when removing. This tie supports the cooling coil during shipping only.

Water Distiller Installation Tools

TOOLS REQUIRED:
For Water Distiller Installation
 (A) #2 Phillips screwdriver
 (B) Slotted screwdriver

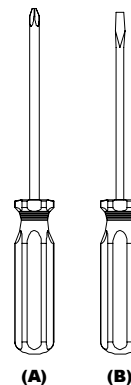

Storage Tank Assembly

1. Disconnect the Control Cable that is between the water distiller head and the storage tank by loosening the locking ring and unplugging. See the **Control Cable Disconnect Diagram** below.

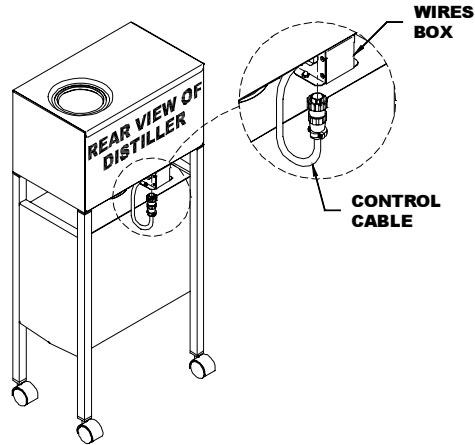

Control Cable Disconnect Diagram

2. Remove the water distiller head from the storage tank by lifting the water distiller head straight up from the storage tank. See the **Water Distiller Head Removal Diagram** below.

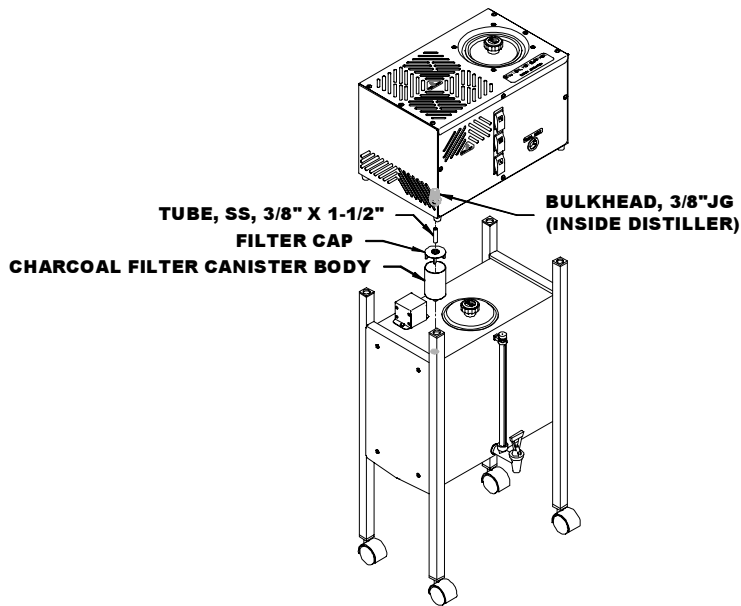

Water Distiller Head Removal Diagram

3. Remove the sight gauge with valve from the parts box.

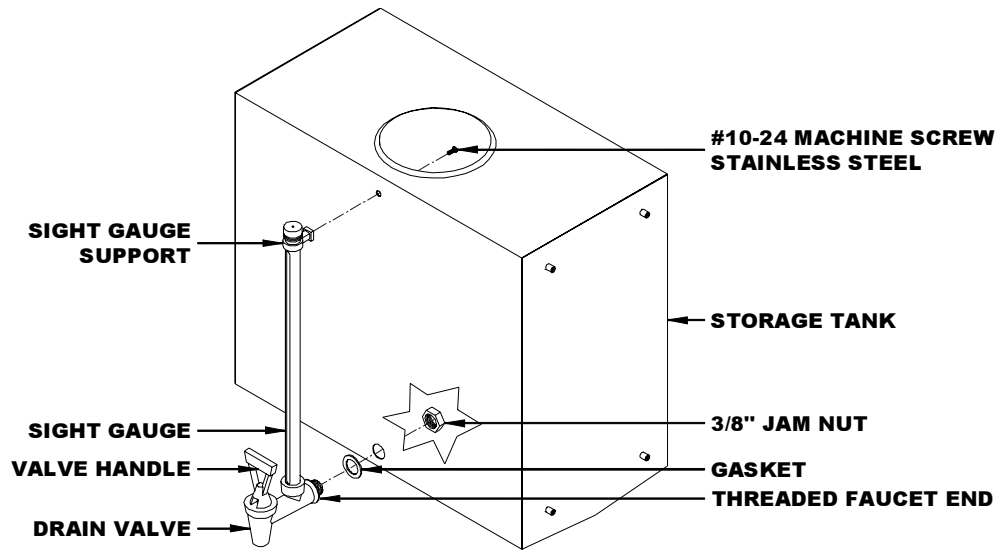

Sight Gauge Installation Diagram

4. Refer to **Sight Gauge Installation Diagram** above. Remove the plastic hex jam nut from the threaded body of the valve (leaving washer gasket on threads).
5. Remove the storage tank lid by holding down on the lid and turning the black knob counter clockwise while lifting, approximately five turns. Slide the lid to one side and turn the knob and lid together while tilting. This should allow the Tee Bar bracket under the lid to come out of the tank opening. Slide the lid out.
6. Push the gasket tightly up against the valve.
7. Insert the threaded valve end with gasket attached through the hole on the front of the storage tank.
8. While holding the sight gauge with valve in the storage tank hole with one hand, insert your other hand with the plastic hex jam nut through the storage tank lid opening.
9. Place the hex nut onto the threaded end of the valve.
10. Hand tighten the hex nut clockwise onto the valve.

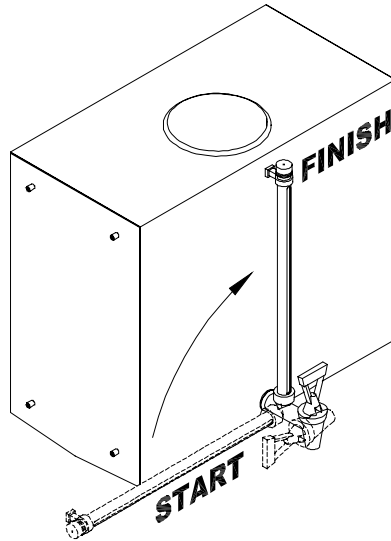

Tightening Sight Gauge Nut Diagram

- 11.** Refer to the **Tightening Sight Gauge Nut Diagram** above. To fully tighten the nut, turn the valve counter-clockwise $\frac{1}{4}$ of a turn to the start position and ensure that the jam nut is still hand tight. Holding the jam nut, turn the valve clockwise until upright at the finish position.

NOTE: The sight glass is fragile, do not push on the gauge (push on bottom near threaded area).

- 12.** Remove the #10-24 screw from the sight gauge support and install through the inside of the storage tank using a Phillips screwdriver. Tighten until snug only.
- 13.** Make sure the storage tank is free from any dust or material and replace the storage tank lid.
- 14.** Check for leaks when storage tank begins filling.

Manual Drain Valve Tube Installation

NOTE: If you have purchased the Automatic Electric Drain Kit, Go to the **PWS AED-1 Automatic Electric Drain Kit Installation** section of the guide and install it now.

1. Refer to the **Manual Drain Valve Tube Installation Diagram** shown below. Push the drain tube onto the elbow and secure with gear clamp using a slotted screwdriver. Run the drain tube to a container or suitable floor drain like the sewer.

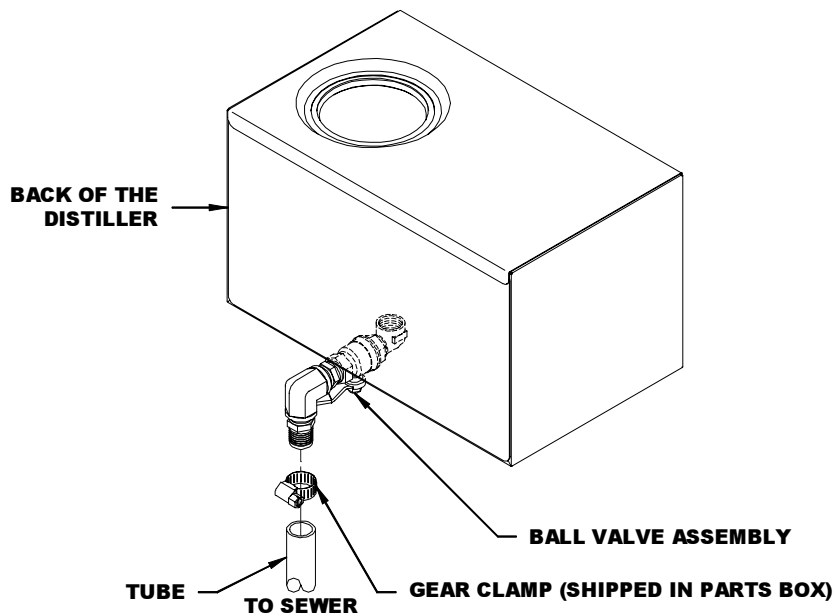

Manual Drain Valve Tube Installation Diagram

Feed Water Line Connection

TOOLS REQUIRED: For Feed Water Line Connection

- (A) Slotted Screwdriver
- (B) Drill with 1/8" drill bit (For Steel or Brass Water Line)
- (C) 1/2" Open End Wrench or
- (D) Pliers
- (E) JG Removal Tool (supplied in Parts Box)
- (F) Utility Knife

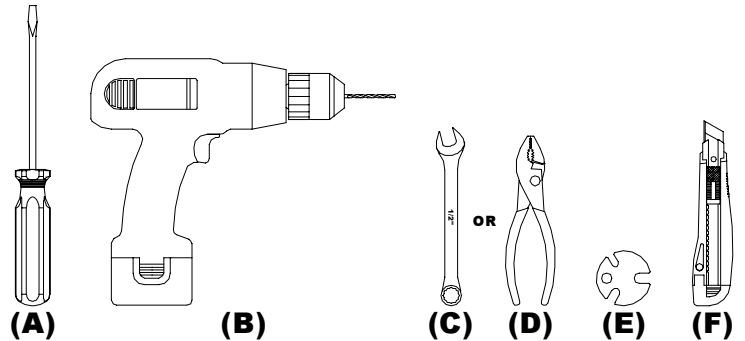

1. Select a household water line to supply the water distiller with feed water. Be sure to use a cold water line and pick a suitable location closest to the water distiller location.

NOTE: If you have a water softener be sure to connect the water distiller feed line on the outlet side of the softener as soft water will reduce cleaning and maintaining of the water distiller. Using a water supply from the outlet of a hot water heater is not recommended as some of the internal components of the water distiller are not designed to be used with water temperatures above normal cold household water supply. Scale and sediment from hot water tanks can also cause problems by plugging the water distiller raw water plumbing components.

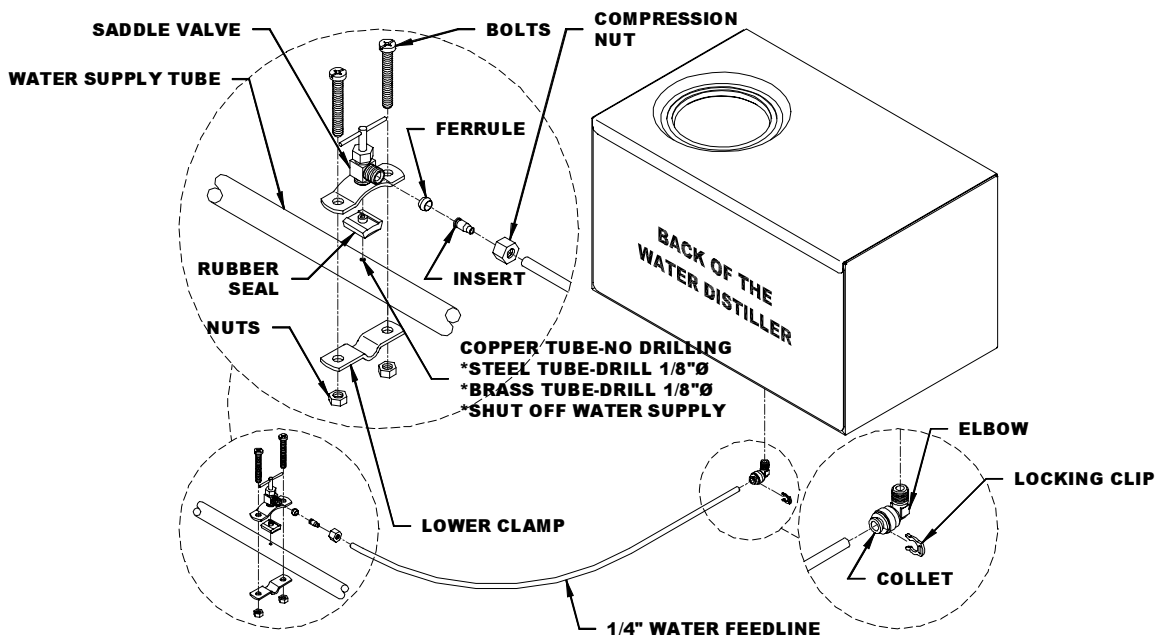

2. Refer to the **Feed Water Line Installation Diagram** above. Install the self-piercing valve kit onto the household water feed line with a slotted screwdriver. Detailed instructions for installing the valve are listed below.

Instructions:

For Copper and Plastic Water Line:

NO DRILLING OR WATER SHUT– OFF REQUIRED.

Caution: Be sure piercing pin is completely backed up into valve body by turning handle counter-clockwise.

1. Loosely assemble one side of top clamp to bottom clamp with screw and nut provided.
2. Be sure rubber gasket is in place over piercing needle and position valve assembly on copper or plastic water line.
3. Assemble other side of top clamp to bottom clamp with remaining screw and nut and tighten both pieces with a slotted screwdriver until valve assembly is firmly attached to water line.
4. Complete compression connection to valve outlet.
5. Turn valve handle clockwise to pierce the supply line and close the valve.
6. Open valve by turning handle counter-clockwise to desired water flow rate.

For Steel and Brass Water Line:

1. Turn off the household water supply.
2. Drill a 1/8" hole at the bottom of the steel or brass water line that will be used for the water distiller water feed line.
3. Loosely assemble one side of top clamp to bottom clamp with screw and nut provided.
4. Be sure the piercing pin is turned into the valve body. Place the rubber gasket over the piercing needle and position needle into drilled 1/8" hole.
5. Assemble other side of top clamp and bottom clamp with remaining screw and nut and tighten both pieces with a slotted screwdriver until valve assembly is firmly attached to the water line.
6. Complete compression connection to valve outlet.
7. Turn on household water supply.
8. Open flow rate by turning saddle valve handle counter-clockwise to desired flow rate.

3. Attach the 1/4" water line to the self piercing valve with a ferrule, insert and compression nut using a 1/2" open end wrench or pliers. Route the 1/4" tubing to the inlet on the back of the water distiller head. Cut approximately one foot longer than needed with suitable water line routing.
4. Remove the existing piece of 1/4" tubing from the elbow (installed for shipping purposes only) on the bottom rear of the water distiller head using a slotted screwdriver or JG removal tool to remove the locking clip on the elbow. Push in on the dark grey collet with the JG removal tool and pull out the piece of 1/4" tubing.

5. Push the ¼" household feed line fully into the elbow and reinstall the locking clip between the elbow and collet.
6. Make sure the Control Cable is connected between the water distiller head and the storage tank by turning the plug until the splines lock and then turn the locking ring until finger tight. See the **Control Cable Connection Diagram** below.

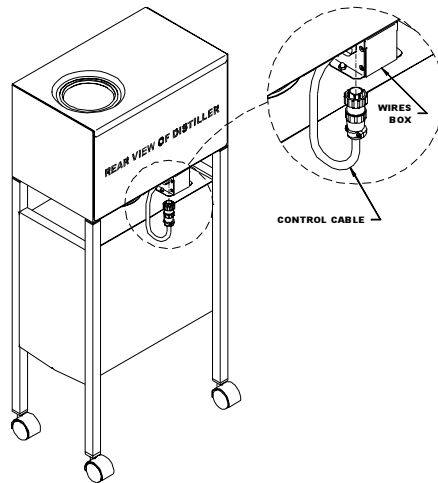

Control Cable Connection Diagram

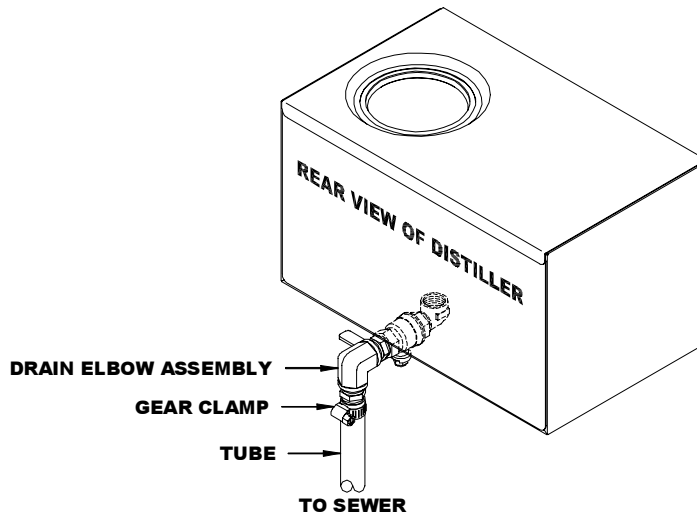

Boiling Tank Drain Valve Diagram

7. Refer to the **Boiling Tank Drain Valve Diagram** above. Close the boiling tank drain ball valve at the rear of the water distiller (ball valve is shown in the closed position). If the water distiller is equipped with the PWS AED-1 Automatic Electric Drain the ball valve should be in the open position.
8. Tighten the saddle valve handle completely by turning clockwise to pierce the water supply line (copper or plastic water line only). Open the water supply to the water distiller by turning the saddle valve handle counter-clockwise. Check for leaks.

Boiling Tank Lid Installation

1. Remove any protective plastic coating (white, blue or clear plastic) from the lid.

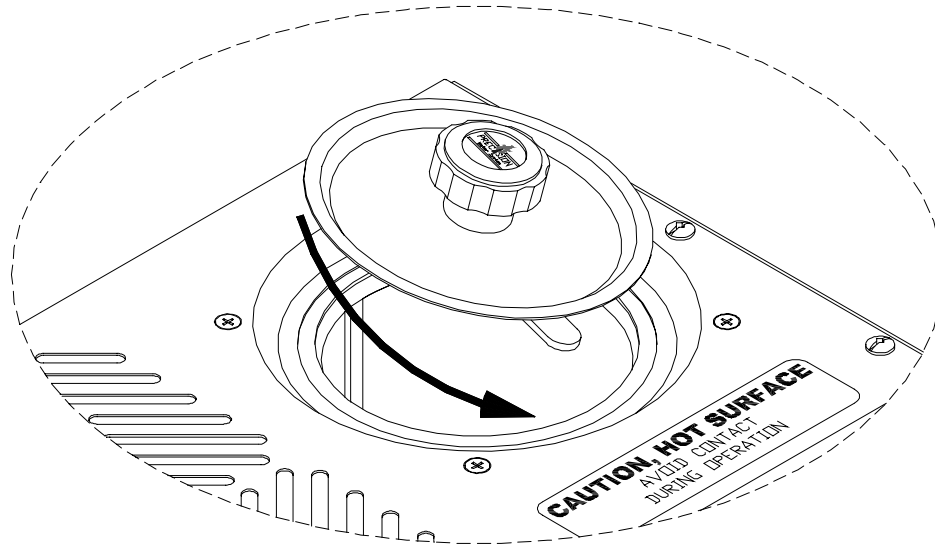

Boiling Tank Lid Operation Diagram

2. Refer to the **Boiling Tank Lid Operation Diagram** above. Take the boiling tank lid in your hand. Hold the Tee Bar bracket and turn the Lid Knob counter-clockwise so that there is $\frac{1}{2}$ " of space between the Tee Bar bracket and the lid.
3. Tip the lid so that the Tee Bar bracket slips under the rim of the boiling tank opening on one side, and then slide the lid so the Tee Bar bracket slips under the other side of the rim. Center the lid.
4. Turn clockwise to tighten the lid onto the boiling tank. The water level pin inside the boiling tank will prevent the lid from turning while tightening. Practise removing and replacing the lid a few times as the lid will need to be removed each time the water distiller is cleaned.

Storage Tank Lid Removal and Installation

1. To remove the storage tank lid, turn the Lid Knob counter-clockwise while lifting. Lifting while turning holds the Tee Bar bracket under the lid and allows you to loosen the lid. Continue turning and lifting until there is $\frac{1}{2}$ " of space between the Tee Bar bracket and the lid.
2. Tip the lid so that the Tee Bar bracket slips out from under the rim of the storage tank opening on one side, and then slide the lid so the Tee Bar bracket slips out from under the other side of the rim.

3. To replace the storage tank lid, tip the lid so that the Tee Bar bracket slips under the rim of the storage tank opening on one side, and then slide the lid so the Tee Bar bracket slips under the other side of the rim. Center the lid.
4. While lifting up on the storage tank lid knob, turn clockwise to tighten the lid onto the storage tank. Tighten until snug only.

Water Distiller Wall Stabilizer

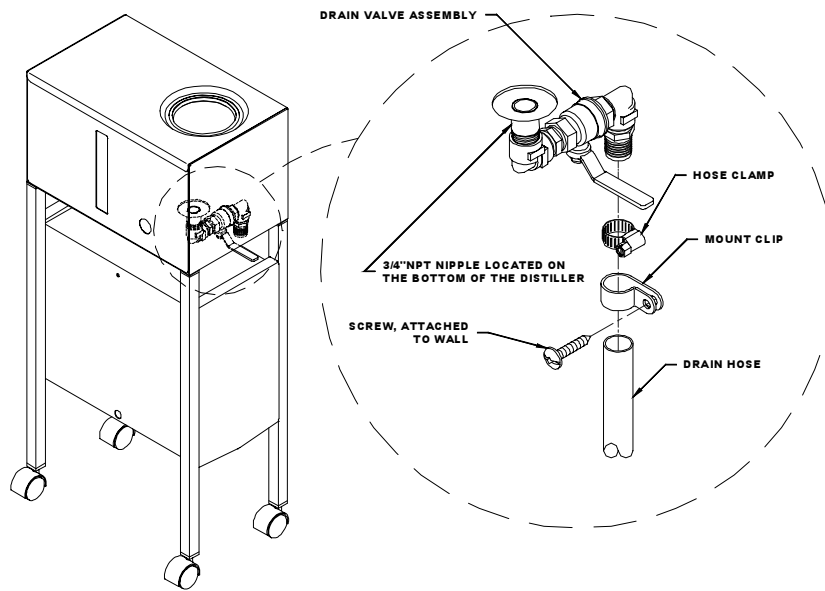

Water Distiller Wall Stabilizer Diagram

According to the Canadian Electrical Code, it is required that you secure the water distiller to the wall or a secure mounting surface. This will ensure that the water distiller can never be upset. See the **Water Distiller Wall Stabilizer Diagram** above. Mount the water distiller using a slotted screwdriver, a 1-1/4" plastic clip and a #10 x 1" screw.

Operation

NOTE: Read all parts of the Owners Guide before operating the water distiller. Follow the Before Initial Water Distiller Operation steps and be sure to complete a Steam Sterilization of the Water Distiller Head, Filter Canister and Storage tank before distilling water for household use for the first time or after a period of storage or non-use.

Controls

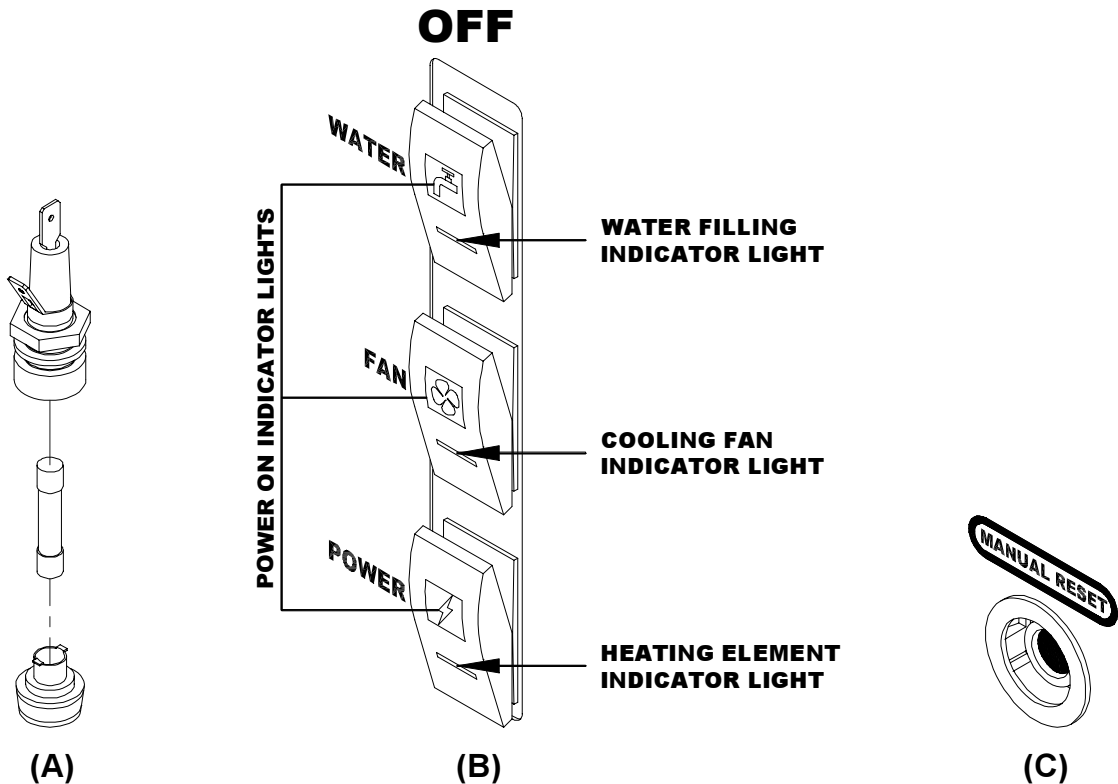

Operation Switches Diagram

Refer to the **Operation Switches Diagram** above. There is a replaceable 1 Amp Slow Blow 240V fuse **(A)** on the bottom rear of the water distiller head. There are three grey control switches **(B)** and one overheat manual reset switch **(C)** on the front of the water distiller head that allow you to control all functions of the water distiller

Power – ON/OFF

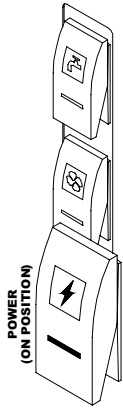

- Red indicator light.
- Normally ON when water distiller is operating. Controls power to the entire water distiller.
- Top square indicator light is illuminated whenever the switch is on. It will remain illuminated even when the water distiller is not operating.
- Bottom rectangular indicator light is illuminated only when the heating element in the boiler is on.
- Turn power switch to OFF to stop Water distiller operation.

NOTE: A clicking sound may be heard if the Water distiller is plugged into the wall electrical outlet, the power and water switches are in the 'ON' position and the boiler is empty. The clicking sound is the internal water solenoid valve activating.

Fan – ON/OFF



- Amber indicator light.
- Normally ON when water distiller is operating. Controls power to the cooling coil fan.
- Top square indicator light is illuminated whenever the switch is on. It will remain illuminated even when the water distiller is not operating.
- Bottom rectangular indicator light is illuminated only when the fan is on. Fan should be running if the water distiller is distilling water.
- Turn Fan Switch to OFF only when performing a steam sterilization of the water distiller.

Water – ON/OFF

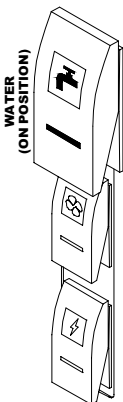

- White indicator light.
- Normally ON when water distiller is operating with automatic feed water supply line. Will automatically fill the boiler tank from the water supply line.
- Top square indicator light is illuminated whenever the switch is on. It will remain illuminated even when the water distiller is not operating.
- Bottom rectangular indicator light is illuminated only when the water is entering the boiling tank. The boiler will fill with water until the upper boiler water level is achieved.

Overheat Reset Switch – Manual Reset

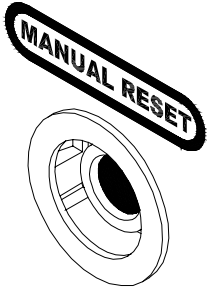

- Recessed into the front of the water distiller head front cover.
- The reset button will shut the unit off if the water distiller has overheated, it may be reset once the water distiller has cooled off. If the situation continually repeats itself this may also indicate a problem and should be looked at by a service center.
- The reset button is a safety feature and is designed to shut the water distiller down should it overheat.
- Push your finger through the hole in the front cover labelled 'Manual Reset' to reset. A snap will be heard when the switch is reset and distilling can resume.

Fuse – 1 Amp Slow Blow 240V

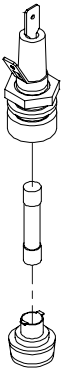

- This is a feature to protect the pump option electrical circuit and is located on the bottom of the water distiller head at the rear.
- Always replace with the proper fuse.

Storage Tank Drain Valve

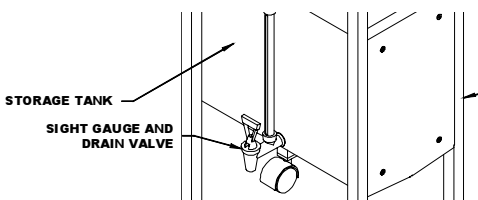

To enjoy pure water from your water distiller storage tank use the storage tank drain valve on the front of the storage tank. The valve handle can be tipped one way to control the flow of water or tipped over the opposite direction and locked in the open position to fill large containers. Water can be pumped automatically to a faucet at the kitchen sink or other location by installation of an Optional Pump Kit. See **PWS APK-1 Pump Kit and PWS APK-1 Pump Kit Installation** in the **Optional Accessories Section** for a diagram of the kit and installation instructions.

Before Initial Water Distiller Operation

1. Ensure the boiling and storage tank lids are in place and tight.
2. Make sure all control switches are turned off. (See Operation-Controls Section if not sure how to operate).
3. Ensure the water supply saddle valve is turned fully on by turning counter-clockwise from tight.

NOTE: Manual Fill Operation (If a pressurized water supply is not available such as using the water distiller at a cottage or on vacation) – Fill the boiler tank by removing the boiler tank lid and pouring water into boiler tank up to bottom of the water level pin. Refer to **Boiling Tank Water Gauge Pin Diagram**.

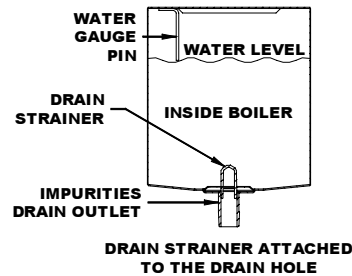

Boiling Tank Water Gauge Pin Diagram

4. Plug Water distiller into a wall outlet.
5. Turn Power, Fan and Water switches ON (Do not turn Water switch on if filling manually).
6. Water should be entering the boiling tank. Remove the boiling tank lid to check. Replace lid if water is entering. The fan and heater should turn on as soon as the water level is above the heating element.
7. Check for leaks around the saddle valve and supply pipe and around the water solenoid on the water distiller head. See **Water Solenoid Valve in Water Distiller Head Diagram** below.

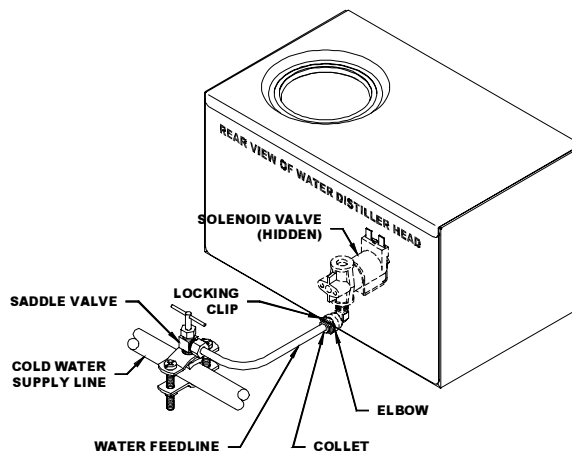

Water Solenoid Valve in Water Distiller Head Diagram

8. If there are no leaks and the water distiller is operating as described above, shut all control switches off and perform steam sterilization on the water distiller head, filter canister and storage tank as described in the **Maintenance and Cleaning** section.

Normal Operation

1. Ensure boiling and storage tank lids are in place and tight.
2. Ensure all electrical plugs are properly connected and the water supply valve is turned on.
3. Turn the Power, Fan and Water switches to the ON position. Water will enter the boiling tank, the heating element will energize and the cooling fan will start.
4. The water distiller will continue operating and distilling water until the storage tank is full. At this time the water distiller will turn off until the storage tank is drained to approximately 2/3 full and then the automatic water distiller will start producing distilled water again.
5. To prevent a build up of scale and contaminants in the boiling tank, it is recommended that the impurities from the boiling tank be drained after each distillation process or ten gallons of distilled water. Routinely draining the impurities will prolong the life of the water distiller and reduce cleaning.

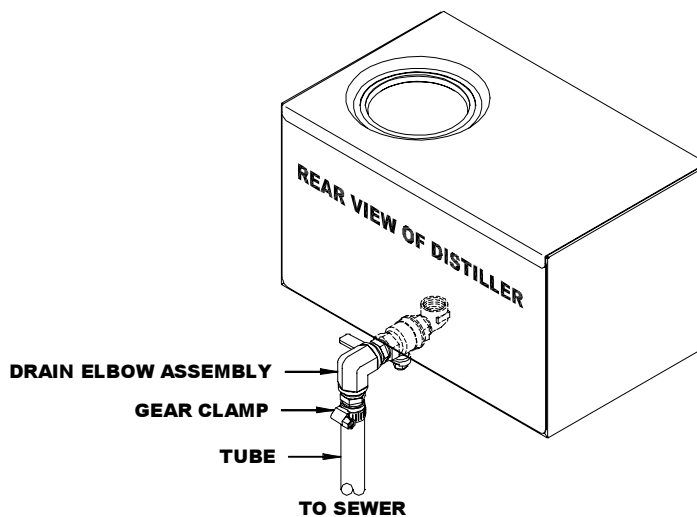

Manual Drain Valve Location Diagram

6. Refer to the **Manual Drain Valve Location Diagram** above. The water distiller boiling tank can be drained by opening the ball valve and draining into a suitable floor drain or container (valve is shown in the close position). The drain may be operated automatically by installation of the Optional Automatic Electric Drain System. See **PWS AED-1 Automatic Electric Drain Kit Installation** in the **Optional Accessories Section** for a diagram of the kit and installation instructions

Maintenance and Cleaning

Introduction

The purpose of purchasing a water distiller is so you will not have to drink the impurities in your drinking water. A water distiller effectively removes the impurities and chemicals from your water and returns the taste of pure water so that it is pleasing and healthy to drink for the entire family.

It is important to also keep the water distiller clean so that it can perform properly and efficiently. Regular cleaning and maintenance will allow the water distiller to continually provide pure water for a very long time.

NOTE: Regular Cleaning is much easier than trying to clean after a prolonged period of time!

Regular Inspection and Cleaning of the Boiling Tank

1. To prevent a build up of scale and contaminants in the boiling tank, it is recommended that the impurities from the boiling tank be drained after each distillation process or ten gallons of distilled water. There may be an off colour line at the seams of the boiler tank, this is caused by the TIG welding process used during manufacturing. This is normal and is not a sign of any concern.

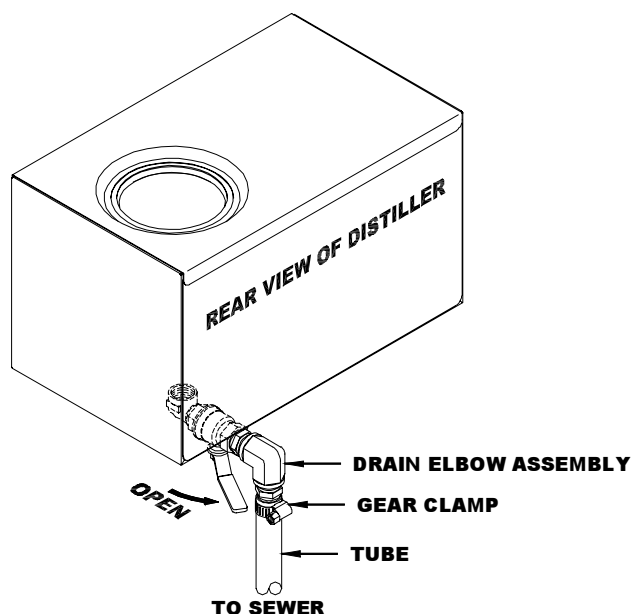

Manual Drain Valve Location Diagram

2. Refer to the **Manual Drain Valve Location Diagram** above. The water distiller boiling tank can be drained by opening the ball valve and draining into a suitable floor drain or container (ball valve is shown in the open position).

3. The drain may be operated automatically by installation of the Optional Automatic Electric Drain System. See **PWS AED-1 Automatic Electric Drain Kit Installation** in the **Optional Accessories Section** for a diagram of the kit and installation instructions.
4. With the manual drain valve or the Automatic Electric Drain it is important to develop a regular maintenance routine. Every two weeks or 50 gallons of distilled water take a look inside the boiling tank when the water distiller is cool.
5. Check for scale build up on the walls of the boiler tank and the heating element. The heating element is the most critical. If there is 1/8" of build up or more on the heating element, then it is time to clean the boiling tank using the descaler cleaner. This process is described in the next section.
6. After checking the boiling tank every two weeks for about three months, you will be able to set up your own schedule as to how often the boiling tank needs to be cleaned with the descaler cleaner. Distilled water quantity use and raw water quality will determine your schedule.

Cleaning the Boiling Tank using the Cleaner Descaler

1. Turn all switches off and allow the water distiller to cool down.
2. If the water distiller is equipped with an Automatic Electric Drain, close the ball valve behind the water distiller head.
3. Remove any loose scale from inside the boiling tank by hand through the boiler lid. Remove the drain strainer and inspect for sediment or plugged holes. Clean if necessary. See the **Boiling Tank Strainer Removal Diagram** below to see how to remove the strainer.

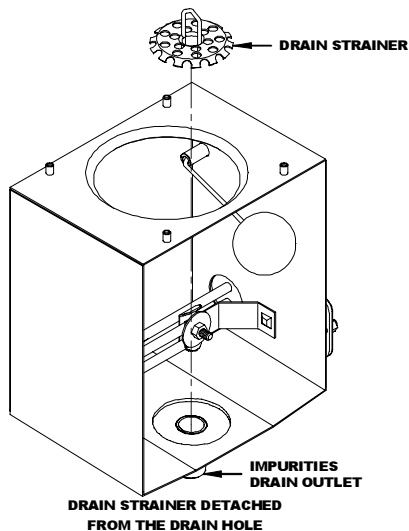

Boiling Tank Strainer Removal Diagram

4. Remove the filter canister and place the sterilization tube onto the coil tube to by-pass the storage tank. See **Steam Sterilization of Water Distiller Head** in this **Maintenance and Cleaning** section for more details.

5. Add 3 tablespoons of descaler cleaner to the boiling tank.

CAUTION: Descaler is a corrosive and poisonous substance. Read safety precautions on the package. As the initial water is added to the descaler in the boiling tank it will produce a bubbling foam substance. Do not overfill the boiling tank. Always leave boiling tank lid off when ever the boiling tank is being descaled to reduce fumes travelling through the cooling coil. Dispose of the first gallon of distilled water as a precaution.

6. Fill the boiling tank half full with hot tap water.
7. Mix the cleaning solution well to dissolve the descaler in the water.
8. Fill up the remaining portion of the boiling tank with hot tap water to the bottom of the water gauge pin. See **Boiling Tank Water Gauge Pin Diagram** below.

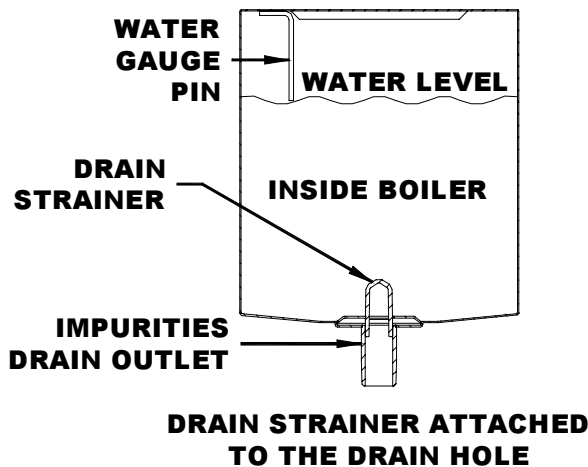

Boiling Tank Water Gauge Pin Diagram

9. Let the solution stand overnight. Leave the boiling tank lid off during cleaning to prevent descaler fumes from entering the cooling coil.
10. The next morning or when the mineral content is soft, drain the boiling tank using the ball valve. Remove any remaining loose scale by hand using rubber gloves.
11. Repeat cleaning if necessary.
12. Once all the scale has been removed, rinse the boiling tank several times with warm tap water and remove any large pieces of scale by hand.
13. Replace the drain strainer. The strainer stops large impurities from plugging the ball drain valve or Automatic Electric Drain valve.
14. Replace the boiling tank lid and complete steam sterilization process on the boiling tank. See **Steam Sterilization** in this **Maintenance and Cleaning** Section. Reinstall the filter canister.
15. The boiling tank is now clean and ready to produce pure water again.

Replacing Charcoal in Charcoal Filter Canister

NOTE: Replace charcoal in filter every 2 months or every 500 gallons of distilled water.

1. Turn all switches off and allow the water distiller to cool down.

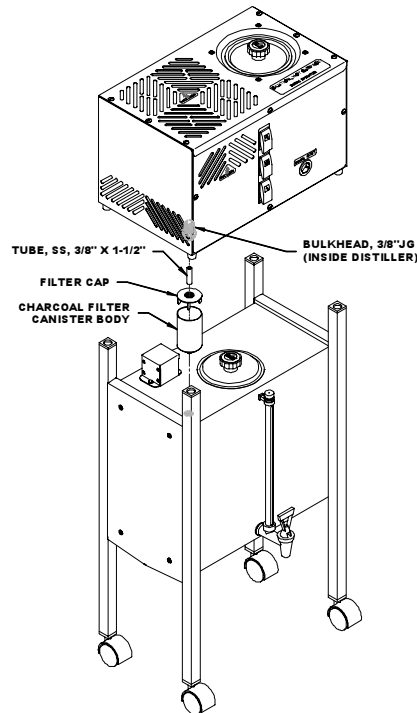

Charcoal Replacement Diagram

2. Refer to the **Charcoal Replacement Diagram** above. Remove the complete charcoal filter canister by lifting the front corner of the water distiller head.
3. Over a sink or suitable garbage can, remove the lid of the filter completely and empty charcoal from canister and rinse.
4. Fill canister 2/3 full with new charcoal and rinse over a sink or pail with approximately 2 cups of distilled water until water runs clear.
5. Press the filter cap back on to the filter canister.
6. Lift the corner of water distiller head and slide the filter into the storage tank and lower the water distiller head so the 3/8" tube enters the top of the filter.

Sterilization

Introduction:

Steam Sterilization should be performed on the water distiller boiler, filter canister and storage tank before the water distiller is used for the first time or after a period of storage or non-use. After initial sterilization, the boiler should be steam sterilized after any maintenance is performed and/or cleaning including the descaling process. The storage tank requires cleaning and steam sterilization after any maintenance, or if there are any problems with the quality of the distilled water.

If there is a water quality concern and the system may be contaminated, it is important to first remove the source of contamination and remove all contaminated debris and then complete a Liquid Sterilization before a Steam Sterilization.

Liquid Sterilization of Storage Tank and Optional Pump Water Line System

NOTE: This is performed whenever it is suspected that the water distiller head, storage tank or pump water line system are contaminated.

1. It important to first remove the source of contamination and remove all contaminated debris before liquid sterilization.
2. Drain the water distiller and water lines as much as possible.

NOTE: Liquid Sterilization Solutions can be made from Household bleach. The bleach should be diluted to 100-200 PPM. Products such as Javex, have 6% Sodium Hypochlorite and should diluted by placing 3 teaspoons per gallon of water. Always use Chlorine bleach that does not contain any other ingredients. Alternatively, Hydrogen Peroxide solutions may be used by placing 3 teaspoons per gallon of water.

3. Add 2 gallons of Liquid Sterilizing solution to the water distiller storage tank. If desired, spray some of the solution throughout the inside of the storage tank. You may need more sterilization solution if you are using more that 25 feet of pump water line.
4. Run the pump by opening the faucet at the kitchen sink to put sterilizing solution through all water lines and dispensers. All the lines will be full of sterilization solution when you can smell the solution at the faucet. Wait 20 minutes.
5. Rinse the entire inside of the storage tank with at least 2 gallons of distilled water. Run the pump to clear the lines of the sterilizing solution.
6. Repeat the flushing of the storage tank with distilled water 2-3 times, rinsing the pump and all water lines at the same time. Continue until no chlorine smell is coming from the faucet.
7. Complete a Steam Sterilization of the boiling and storage tanks.

Steam Sterilization of Water Distiller Head

1. Make sure the water distiller is cool before starting.

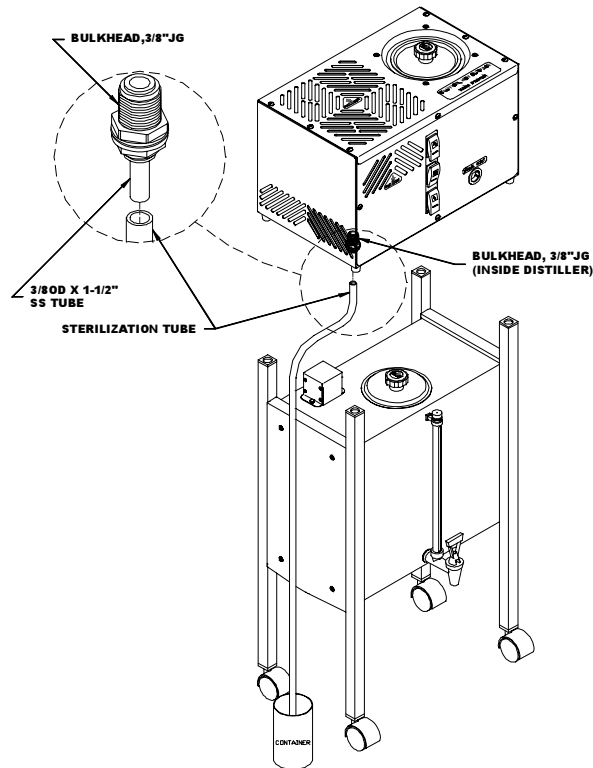

Water Distiller Head Steam Sterilization Diagram

2. Refer to the **Water Distiller Head Steam Sterilization Diagram** above. Lift the front corner of the water distiller head.
3. Remove the charcoal filter.
4. Install the sterilization tube. Place the sterilization tube on the 3/8" stainless steel filter inlet tube on the bottom of the water distiller head.
5. Place the other end of the steam sterilization tube into a container as it will drip water and steam.

NOTE: If Water Distiller is filled manually, fill the boiling tank with water to the bottom of the water gauge pin.

6. If you are completing the steam sterilization for the first time, plug the water distiller into a dedicated wall outlet.



Steam Sterilization Operation Switches Diagram

7. Refer to **Steam Sterilization Operation Switches Diagram** above. Turn only the power and water switches ON. Leave the fan switch OFF. As the water distiller continues to heat up, it will sterilize the water distiller with steam by allowing pure steam to travel out of the cooling coil. Water and steam will drip from the sterilization tube. **Caution: The Water Distiller is extremely hot during sterilization.**
8. Leave the water distiller on for 1 hour.
9. After sterilization cycle is complete. Turn the fan switch ON and allow any water in the cooling coil to drain. Leave the water distiller running with the fan on for about 15 minutes.
10. The water distiller will be very hot so turn all switches OFF (power, water, fan) and let the water distiller cool down for approximately 1 hour.
11. Remove the sterilization drip tube by pulling the plastic tube off the stainless steel charcoal filter inlet tube (keep the sterilization tube for future sterilizations).
12. Replace the charcoal in the charcoal filter canister. See **Replacing Charcoal in Charcoal Filter Canister** in this **Maintenance and Cleaning Section**.
13. The water distiller head is sterilized and ready for operation.

Steam Sterilization of Water Distiller Head, Filter Canister and Storage Tank

1. Make sure the water distiller is cool before starting.

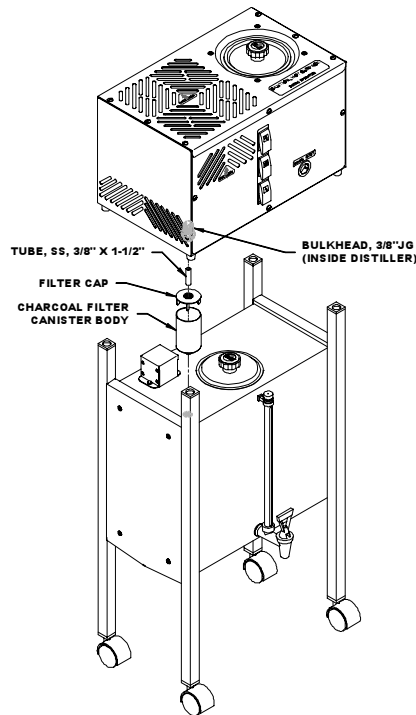

Water Distiller Head, Filter Canister and Storage Tank Steam Sterilization Diagram

2. Refer to the **Water Distiller Head, Filter Canister and Storage Tank Steam Sterilization Diagram** above. Lift the front corner of the water distiller head.
3. Remove the charcoal filter canister. Remove all charcoal and rinse until clean. Replace empty filter canister between water distiller head and storage tank
4. Place a container under the front storage tank sight gauge valve and leave the valve in the open position.

NOTE: If Water Distiller is filled manually, fill the boiling tank with water to the bottom of the water gauge pin.



Steam Sterilization Operation Switches Diagram

5. Refer to **Steam Sterilization Operation Switches Diagram** above. Turn only the power and water switches ON. Leave the fan switch OFF. As the water distiller continues to heat up, it will sterilize the water distiller head, filter canister and storage tank with steam by allowing pure steam to travel out of the cooling coil. Water and steam will drip from the storage tank valve. **Caution: The Water Distiller is extremely hot during sterilization.**
6. Leave the water distiller on for 1 hour.
7. After sterilization cycle is complete. Turn the fan switch ON and allow any water in the cooling coil to drain. Leave the water distiller running with the fan on for about 15 minutes.
8. The water distiller will be very hot so turn all switches OFF (power, water, fan) and let the water distiller cool down for approximately 1 hour.
9. After cooling down, the water distiller may need to be tipped or rocked forward and back to remove all the water from the storage tank.
10. Close the storage tank sight gauge valve.
11. Replace the charcoal in the charcoal filter canister. See **Replacing Charcoal in Charcoal Filter Canister** in this **Maintenance and Cleaning Section**.
12. The water distiller head, filter canister and storage tank are sterilized and ready for operation.

Maintenance Schedule Table

	Initially	Weekly	Monthly	Semi-Annually	Annually	As Needed
1) Check Scale Build Up.		X				X
2) Change Charcoal in Charcoal Filter Canister.	X		X			X
3) Clean Boiling Tank using Cleaner Descaler.			X			X
4) Steam Sterilization of Boiling Tank after cleaning.						X
5) Steam Sterilization of Boiler and Storage Tanks.	X					X

Owner Maintenance Record Table

	Change Charcoal in Charcoal Filter Canister	Clean Boiling Tank using Cleaner Descaler	Steam Sterilization of Boiling Tank	Steam Sterilization of Boiling and Storage Tanks	
Date	Jan 21/03				
Completed By	BDR				
Date					
Completed By					
Date					
Completed By					
Date					
Completed By					
Date					
Completed By					

Troubleshooting

Caution! Always Disconnect Water Distiller Electrical plug and Let the Water Distiller cool down completely before completing any Troubleshooting.

PROBLEM	CAUSE
<p>A) Water distiller does not operate.</p>	<ol style="list-style-type: none"> 1. Water distiller is not plugged in securely to the wall outlet or the circuit breaker is off. 2. Power switch on the water distiller is turned off 3. Reset button has shut the unit off. The reset button will shut the unit off if the water distiller has overheated, it may be reset once the water distiller is cooled off. This may also indicate a problem and should be looked at by a service center. The reset button is a safety feature and is designed to shut the water distiller down should it overheat. Push your finger through the hole in the front cover labelled 'Manual Reset' to reset. 4. Reset button is faulty and needs to be replaced. Call Service Center. 5. The Storage tank is full of water. The storage tank water level must be lowered below 2/3 before the water distiller will operate. 6. Saddle valve is turned off. Turn it on.
<p>B) Water is coming out from the top of the charcoal filter.</p>	<ol style="list-style-type: none"> 1. Charcoal is old and compacted. Replace coconut charcoal. See Maintenance section- Replacing Charcoal in Charcoal Filter Canister. 2. Water solenoid valve has malfunctioned and is stuck open allowing water to flow from the boiling tank to the storage tank before it is distilled. Call Service Center. 3. The boiler fill micro switch requires adjustment or is faulty and needs to be replaced. The boiler tank overfills and flows into the charcoal filter. Call Service Center. 4. Check to see that boiler tank water level float is floating. If it is not floating properly this could be the problem. Call Service Center. 5. Charcoal filter is more than 2/3 full. There must be an air gap between the charcoal and the top of the filter. Remove Charcoal filter and make sure charcoal filter is only 2/3 full.

PROBLEM**CAUSE**

C) Steam or water is escaping from the top of the cooling coil.	<ol style="list-style-type: none">1. The cooling coil is equipped with a gas release vent, a very small hole in the top of the coil. This is to release certain volatile gases. Steam may escape from this hole. This is normal.2. If little or no water is being produced the cooling coil may have become disconnected from the boiling tank. Call Service Center.
D) Charcoal Filter is very hot and steam is escaping from the filter.	<ol style="list-style-type: none">1. The fan switch is turned off. Check Switch.2. Fan motor is not running properly, may be defective, or the fan motor switch may be defective. Call Service Center.3. Cooling coil fins are plugged with dust, dirt, or grease. Remove and clean or take to a service center for maintenance.4. The location of the water distiller does not provide enough airflow for good cooling. Move the water distiller to an area with more air movement.
E) Boiling tank will not fill with water.	<ol style="list-style-type: none">1. The self-piercing saddle valve is turned off. Check and turn on if necessary.2. The direct water feed line may be obstructed or kinked. Check and fix.3. The water switch and/or the power switch are off. Check switches.4. The float in the boiling tank may be stuck. Check by opening boiler tank and lifting gently up on ball float.5. Opening for water feed line inside the boiling tank may be scaled up. Check by opening boiler tank and checking scale build up.6. Manual reset button has tripped. See A) 3. above.7. Storage tank is over 2/3 full. Normal Operation.8. Water Fill Micro Switch Faulty. Call Service Center.9. Solenoid valve is faulty. Call Service Center.
F) Water distiller may start to boil, then shuts off. It may restart after cooling down. Very small amount of water is produced.	<ol style="list-style-type: none">1. Faulty Reset button. After letting water distiller cool down and trying to reset several times, call Service Center.

PROBLEM**CAUSE**

G) Water distiller runs properly but little or no water is produced.	<ol style="list-style-type: none">1. Improper Heating Element is installed or Heating Element is faulty. Call Service Center.2. Auto drain valve is partially stuck open due to scale build up in the valve. Check valve and/or flush by pouring water through the top of the boiler tank opening.3. Auto drain valve is open because it is not plugged into the water distiller head. Check and re-connect.4. Boiler tank lid is loose. Check by moving Boiler Tank Lid Knob.5. Reset button may be defective or weak. See A) 3 above.6. Water supply may be restricted. Turn off saddle valve. Remove Feed Water line from back of water distiller. Place Feed Water line into a pail, turn on saddle valve and check water flow.
H) Strange taste in Distilled Water.	<ol style="list-style-type: none">1. Boiling tank and/or storage tank may require cleaning. See maintenance section on cleaning water distiller.2. Boiling tank has over filled, float system or water solenoid has failed and allowed un-distilled water to overflow into the cooling coil. Open boiler tank and check float operation.3. Charcoal filter requires new Coconut Charcoal.4. Auto-Drain has malfunctioned. Check boiling tank for scale build up. See maintenance section.5. Distilled water line may need cleaning. See maintenance section.
I) Fan does not operate automatically.	<ol style="list-style-type: none">1. Fan switch is in OFF position. Check Switch.2. Fan motor may be defective. Call Service Center.3. Storage tank is full and the water distiller has shut it self off until the storage tank is only 2/3 full.

PROBLEM	CAUSE
J) With the Pump Option, there is no water at the faucet.	<ol style="list-style-type: none"> 1. Pump plug on the water distiller head is loose. Check plug at rear of water distiller head. 2. Storage tank is empty. Water distiller has quit. See A) above. 3. There is no power to the pump. Check to make sure the pump is plugged into the water distiller head. Check to make sure there is power at the wall outlet. 4. Fuse on the water distiller head needs replacing. 5. Pump motor failure. Call Service Center. 6. Kinked water line between the pump and the faucet. Check water line for kinks. 7. Bottom float in the storage tank is stuck or faulty. Open water distiller storage tank and check level sensor. Call Service Center.
K) With Pump Option, pump starts and stops without drawing any water	<ol style="list-style-type: none"> 1. Small leak in the water line or faucet. Check water line for leaks. 2. Loose fittings on pump or lines. Check fittings for leaks-with proper wrench. See Pump Kit Installation Section. 3. Check-valve in pump may be stuck open. Call service center.
L) Water distiller does not operate and storage tank is empty.	<ol style="list-style-type: none"> 1. Storage tank level sensor assembly is faulty. Open storage tank and check level sensor operation. 2. Storage tank level sensor relay is faulty. Call Service Center. 3. Control Cable is not connected. Check connection between water distiller head and storage tank. 4. Check to make sure there is power at the wall outlet. 5. Make sure all control switches are on.
(M) Storage tank only fills 2/3 full and will not fill to the top.	<ol style="list-style-type: none"> 1. Storage tank level sensor is faulty. Top float is stuck in full position. Open storage tank and check floats on level sensor. Call Service Center.
(N) Distiller does not seem to produce as much water as specified.	See Section in Guide: 10 Factors That Will Affect Your Water Distiller Production.

Contact any Precision Water System Service Center to correct any problems with your water distiller that are not covered in this guide.

To locate a Service Center in your area contact the manufacturer at:

Precision Design & Manufacturing Inc.

10331-105 Street,

Westlock, Alberta, Canada

T7P 2H7

<http://www.precisioncanada.com>

e-mail: info@precisioncanada.com

Phone: (780) 349 4933

FAX: (780) 349 4957

Optional Accessories

PWS APK-1 Pump Kit

The PWS APK-1 Pump Kit allows the convenience of having distilled water at your kitchen and includes a pantry faucet. The pump also allows you to connect other appliances that would benefit from distilled water like ice makers, water dispensers, humidifiers etc. The PWS APK-1 Pump Kit fits on the bottom of the Water Distiller storage tank.

Your Optional pump kit has been shipped in one box. The diagram below shows all of the parts that will be in the pump kit box.

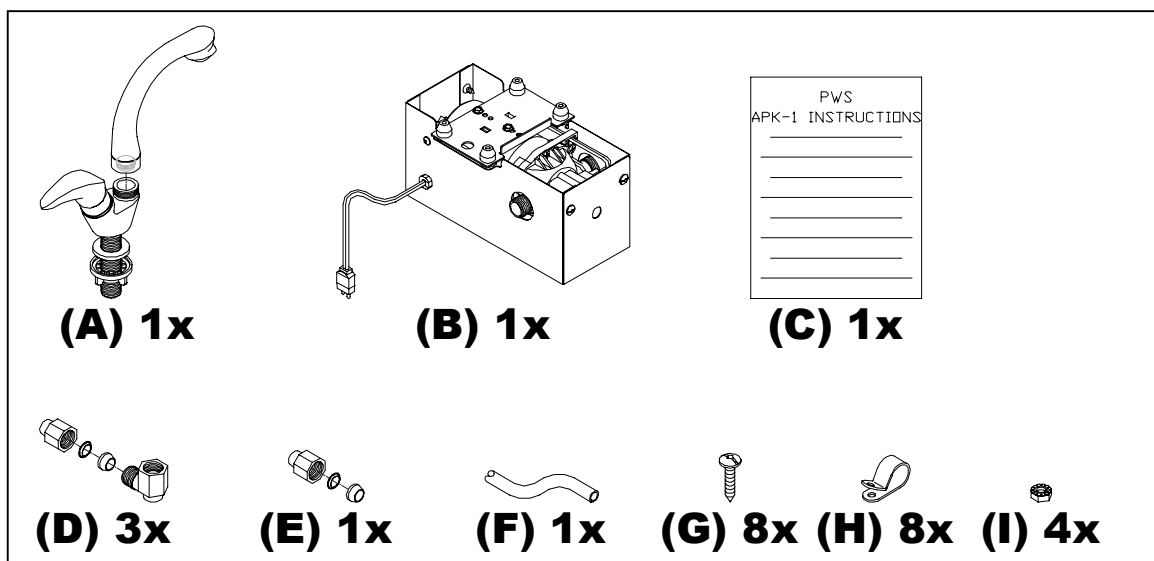

PWS APK-1 Pump Kit Box Components

PWS APK-1 Pump Kit Box Check Off List

Check

List	Part No.	
<input type="checkbox"/> (A)	080052	1 – Pantry Faucet (2 pieces)
<input type="checkbox"/> (B)	500358	1 - Pump Assembly
<input type="checkbox"/> (C)	097010	1 - PWS APK-1 Instruction Sheet
<input type="checkbox"/> (D)	034002	3 - Elbow, 90, 1/2" FPT x 1/2" OD Tube
<input type="checkbox"/> (E)	034003	1 - Nut/Cone/Ring Set
<input type="checkbox"/> (F)	052001	25' - 1/2" OD Plastic Water Line
<input type="checkbox"/> (G)	010008	8 - #10 x 1" Wood screws
<input type="checkbox"/> (H)	054006	8 - White Wall Mount Line Clips
<input type="checkbox"/> (I)	026000	4 - Nut, Kep, #10-24

PWS APK-1 Pump Kit Installation

TOOLS REQUIRED:

For PWS APK-1 Pump Kit Installation

- (A) Basin Wrench
- (B) #2 Robertson Screwdriver
- (C) 10" Adjustable Wrench
- (D) 3/8" Drill
- (E) 3/8" Nut Driver **or**
- (F) Pliers **or**
- (G) Ratchet with 3/8" socket
- (H) Utility Knife
- (I) 5/8" Wood Bit (minimum length of 8")
- (J) 7/8" Hole saw for sink
- (K) JG Removal Tool

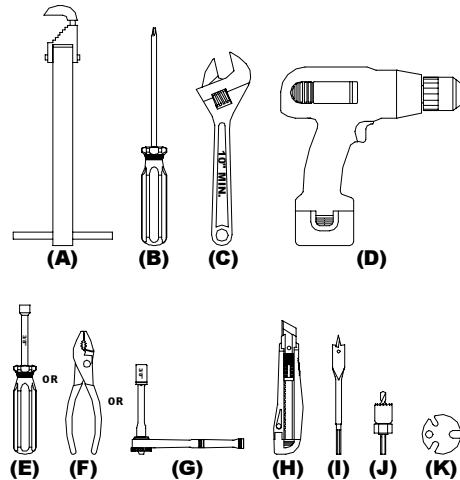

1. Remove all loose pieces from the pump kit box and save all packaging until all the parts are identified and located. If any parts are missing or if you feel you have been given the wrong part, DO NOT return the pump kit. Contact your dealer for the required parts. They will be pleased to assist you.
2. Disconnect the electrical cord and unscrew the Control Cable plug counter-clockwise. If the water distiller has been in use before, be sure to turn off the feed water line saddle valve, disconnect the feed water line, drain the boiling tank and storage tank and remove the wall stabilizer clamp. Remove the water distiller head and charcoal filter canister from the storage tank by lifting off from the storage tank.
3. Turn your water distiller storage tank upside down.

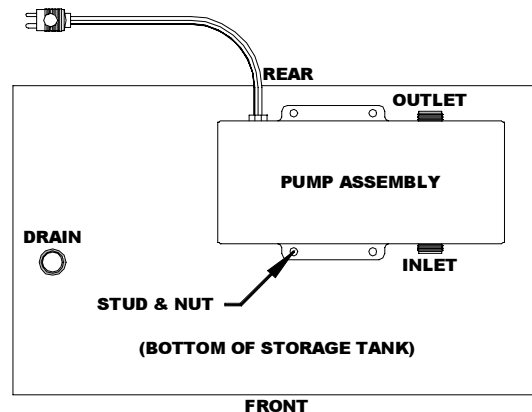

Automatic Pump Mounting Diagram

4. Push the pump over the four #10-24 studs mounted on the bottom of the storage tank. The **Automatic Pump Mounting Diagram** above shows the correct inlet/outlet orientation for the pump.
5. Secure the pump to the storage tank using four #10-24 kep nuts with a 3/8" nut driver, socket and ratchet or pliers.
6. Remove the Grey 1/2" cap from the 1/2" drain nipple on the bottom of the storage tank with a 10" adjustable wrench or pliers.
7. Screw one 1/2" FPT x 1/2" elbow to the nipple where the cap was removed. Tighten using a 10" adjustable wrench so that the elbow points towards the outlet of the pump (No thread sealant is required as these fittings seal with a compression cone).
8. Remove any blue caps from the pump inlet and outlet by unscrewing counter-clockwise (pliers may be required).
9. Remove the Nut, Cone and Ring from the remaining two 1/2" FPT x 1/2" elbows by unthreading counter-clockwise. Keep these in order and available, do not lose them!
10. Screw an elbow onto the inlet side of the pump. Tighten using a 10" adjustable wrench and position towards the first elbow installed on the storage tank drain. Use caution not to over-tighten the elbow onto the pump.
11. Remove the Nut, Cone and Ring from the tank drain elbow.
12. Cut a section of 1/2" OD water line to fit between tank drain elbow and pump inlet elbow.

NOTE: Measure the distance between elbows and add 1 1/2" to allow for inserting hose into elbows: hose length of about 11 inches. See the following Diagram.

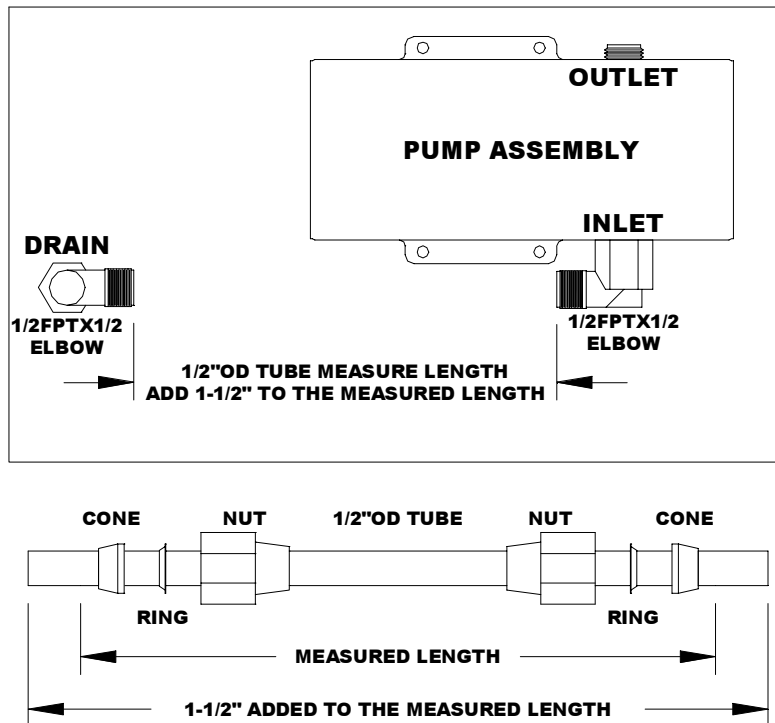

PWS APK-1 Hose Installation Diagram

- 13.** Slide a Nut/Cone/Ring over each end of the 1/2" OD tube and insert the hose into each elbow. Slide the nut to the threads and tighten using a 10" adjustable wrench. Use caution. Do not over tighten.
- 14.** Screw the third elbow to the outlet of the pump. Tighten with a 10" Adjustable wrench in a position that will work for routing the hose to the faucet (usually toward the ceiling or floor). Be careful not to over tighten as you could damage the pump.

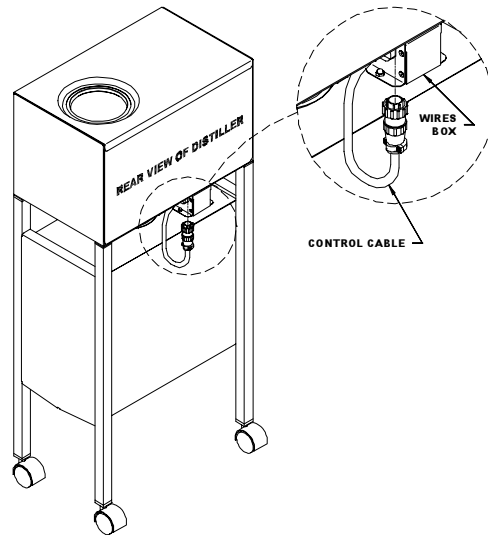

Control Cable Connection Diagram

- 15.** After checking that all fittings are tight, turn the storage tank upright and reinstall the charcoal filter canister and water distiller head on the storage tank. See **Control Cable Connection Diagram** above. Reconnect the control cable plug on the storage tank to the control cable receptacle on the bottom of the water distiller head by turning the plug until the splines lock and then turn the locking ring until finger tight.

Faucet and Water Line Installation for PWS APK-1

- 1.** Now you are ready to attach the pantry faucet to the sink. The kitchen sink is the most desirable location for the faucet as it is close to the cooking area. To install the faucet you will need to drill a 7/8" hole in the sink and counter where you want the faucet. Drill a 5/8" hole through the sub floor of the cupboards and floor to accommodate the water tubing.

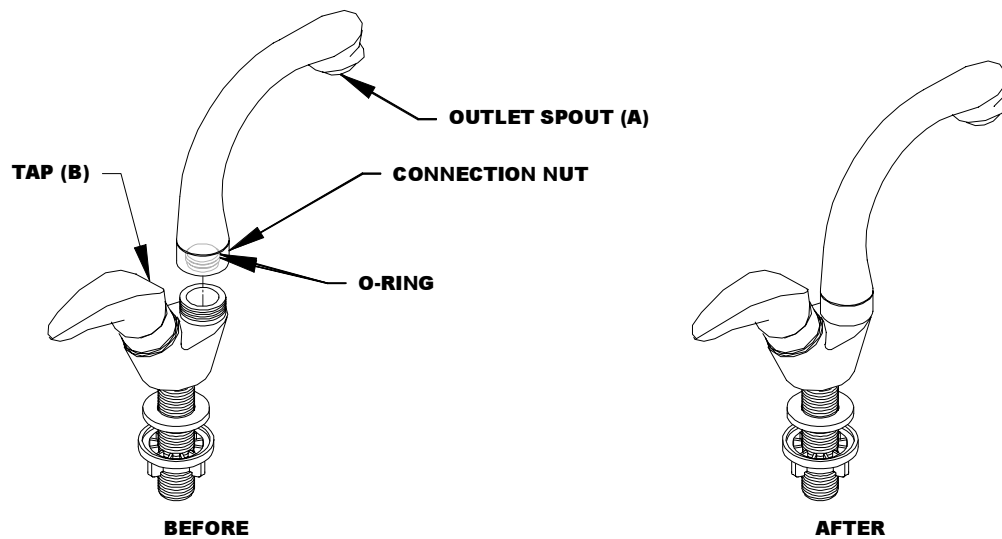

Pantry Faucet Assembly Diagram

2. See **Pantry Faucet Assembly Diagram** above. Connect the two pieces of the pantry faucet by first wetting the O rings on the outlet spout (A) with water or dish soap. Be careful not to damage the O rings when inserting. Slowly rock the spout as you push it into the tap section (B). Use a cloth wrapped around the nut first to prevent damage to the nut when tightening. Turn the nut on the spout with pliers so that it is snug. Do not over tighten. The O rings will provide the seal for the water. The spout can be swivelled for convenience after installation is complete.
3. Install the faucet gasket on the faucet threads and insert the pantry faucet threaded base through the 7/8" hole in the sink. Secure the faucet to the sink with the faucet nut. Tighten with a basin wrench or pliers.
4. Attach 1/2" OD water tube to the pump outlet elbow with a 1/2" Nut/Cone/Ring. Tighten with a 10" adjustable wrench or basin wrench.

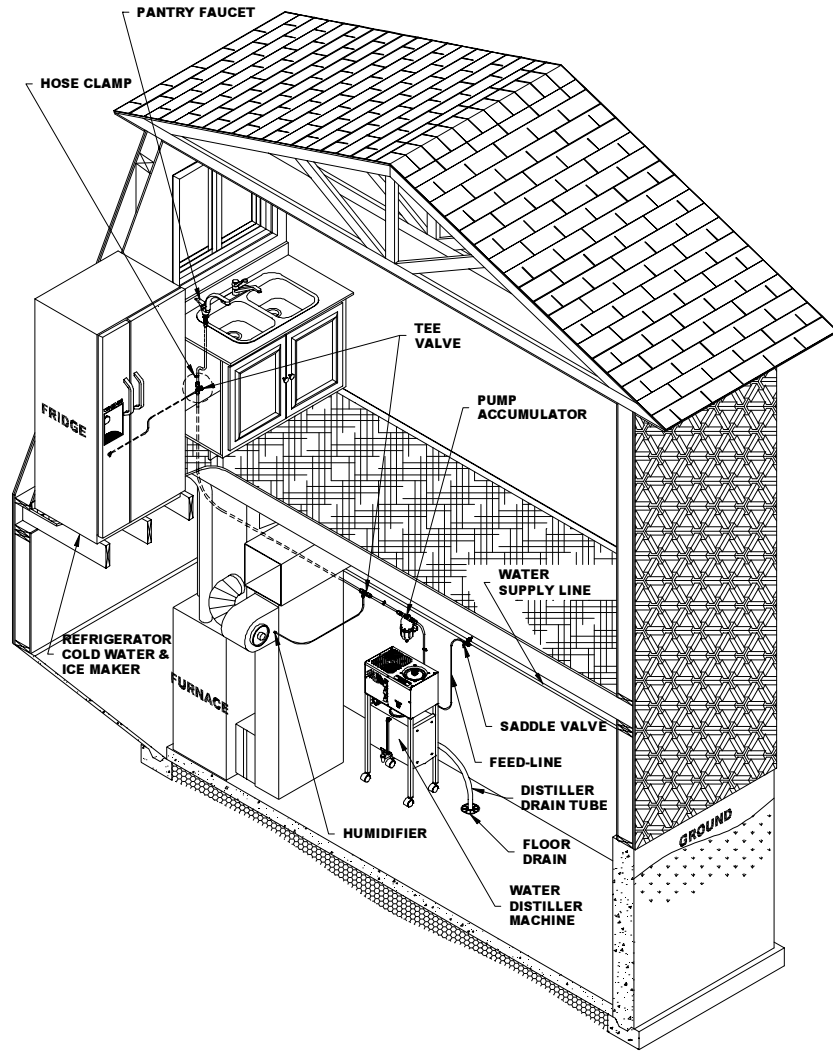

Typical Household Plan for Water Distiller Set up Diagram

5. Route the ½" OD water tube from the water distiller pump to the sink faucet. When routing the water line, consider other possible distilled water uses along the route. The **Typical Household Plan for Water Distiller Set up Diagram** above shows a typical household plan for water distiller set up to a furnace humidifier, fridge cold water and/or icemaker and a kitchen sink faucet.
6. Attach the ½" OD water line to the faucet with a ½" Nut/Cone/Ring. Tighten with a 10" adjustable wrench or basin wrench. Secure the water line using ½" wall mount line clips and #10 x 1" screws.

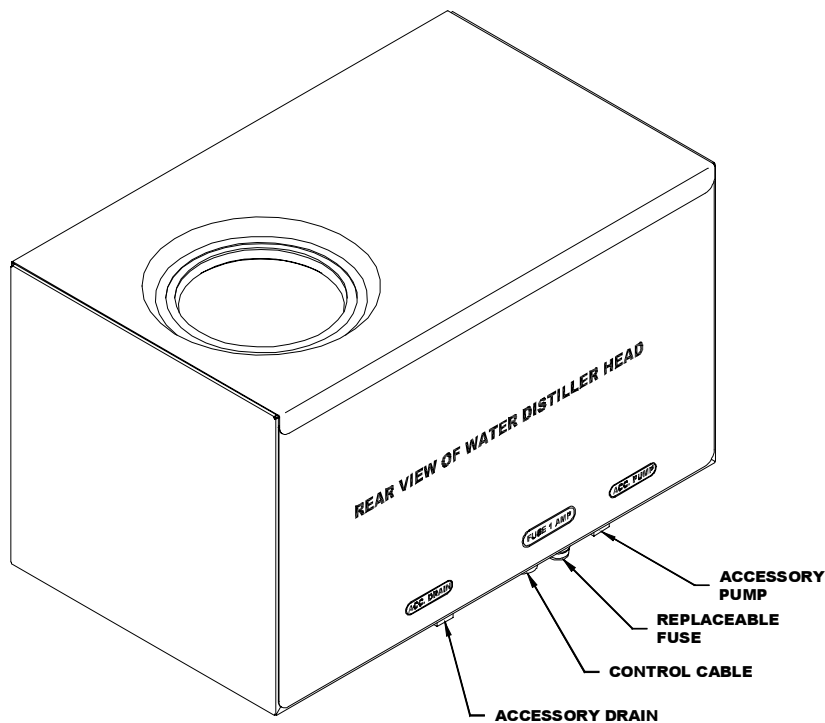

Electrical Connections-Rear View Diagram

7. If the Automatic Electric Drain option is installed on your water distiller, see the **Electrical Connection-Rear View Diagram** above. Reconnect the two-pin plug from the valve motor box into the receptacle labelled 'Accessory Drain' on the bottom of the water distiller head. If the Automatic Electric Drain option is not installed on your distiller, close the manual drain valve. Connect the wall stabilizer clamp. Connect the feed water line and turn the feed water line saddle valve on. Plug the electrical cord into the wall outlet.
8. It is a good idea to fill your storage tank approximately $\frac{1}{2}$ full with distilled water after you install the pump to check the fittings for leaks. If you do not have any distilled water available, let the water distiller run.

NOTE: Keep pump unplugged until you are available to check for leaks upon initial installation

9. Once the storage tank is approximately $\frac{1}{2}$ full, connect the two pin plug from the pump into the receptacle labelled 'Accessory Pump' on the bottom of the water distiller head. The water level switch in the storage tank will automatically turn the pump switch on as soon as it is plugged in and the pump will pressurize your water line. When this happens, check for leaks.
10. To enjoy water at the pantry faucet, lift the lever. The pump will start and stop as required to keep distilled water flowing at the faucet.

PWS AED-1 Automatic Electric Drain Kit Installation

TOOLS REQUIRED:

- (A) 12" Adjustable Wrench
- (B) 10" Adjustable Wrench
- (C) Slotted Screwdriver

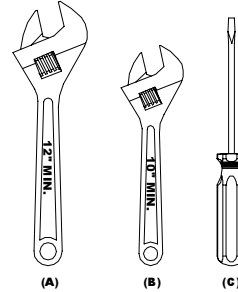

Introduction: The PWS AED-1 Automatic Electric Drain Kit is designed to drain the water distiller boiling tank of impurities automatically, so that you don't have to. Every time you distil water and your storage tank fills up, the water distiller will shut off and the Automatic Electric Drain Option will open and drain the boiling tank of all soluble impurities. The boiler will remain empty until the water distiller restarts, then the drain valve will automatically close and let your water distiller boiling tank refill with fresh water and begin the distillation cycle again.

Your Optional PWS AED-1 kit has been shipped in one box. The Diagram below shows all of the parts that will be in the PWS AED-1 box.

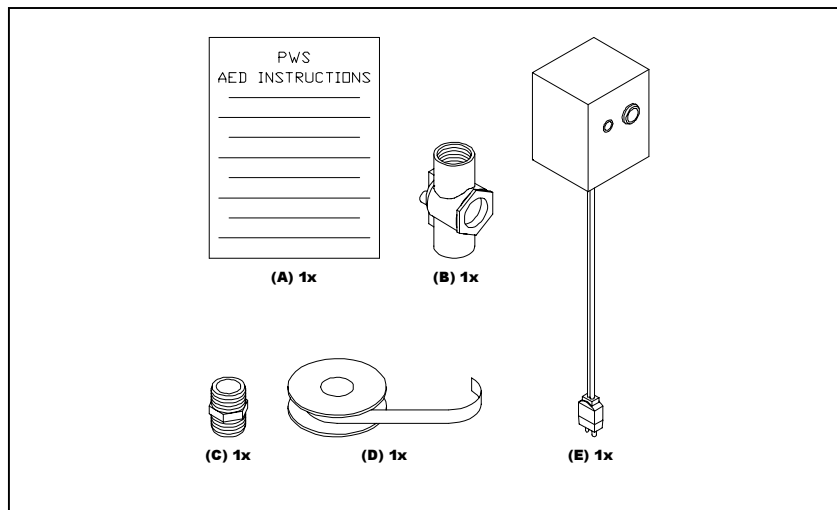

PWS-AED-1 Box Components Diagram
PWS AED-1 Box Check Off List

Check
List

- | Part No. | |
|-------------------------------------|---|
| <input type="checkbox"/> (A) 097090 | 1- Instruction Sheet |
| <input type="checkbox"/> (B) 080077 | 1- Valve Body |
| <input type="checkbox"/> (C) 030017 | 1- 3/4" MPT Close Nipple |
| <input type="checkbox"/> (D) 080109 | 1- Roll Teflon Tape |
| <input type="checkbox"/> (E) 500310 | 1- PWS AED Motor Assembly, W/Cord, 120V |
| 500311 | 1- PWS AED Motor Assembly, W/Cord, 240V |

Remove all loose pieces from the automatic electric drain kit box and save all packaging until all the parts are identified and located. If any parts are missing or if you feel you have been given the wrong part, DO NOT return the automatic electric drain kit. Contact your dealer for the required parts. They will be pleased to assist you.

Installation

NOTE: Do not attach the Drain Valve Body (B) to the Motor Assembly (E) until the valve is installed completely on the water distiller head.

1. If the water distiller has been used without the PWS Automatic Electric Drain, turn off the water distiller, drain the boiling tank and wait for the water distiller to cool off.
2. Disconnect the electrical cord and unscrew the Control Cable plug counter-clockwise. Turn off the feed water line saddle valve, and disconnect the feed water line.
3. If the PWS APK-1 Pump Kit is installed on the water distiller, disconnect the two-pin plug from the Accessory Pump receptacle on the bottom of the water distiller head.

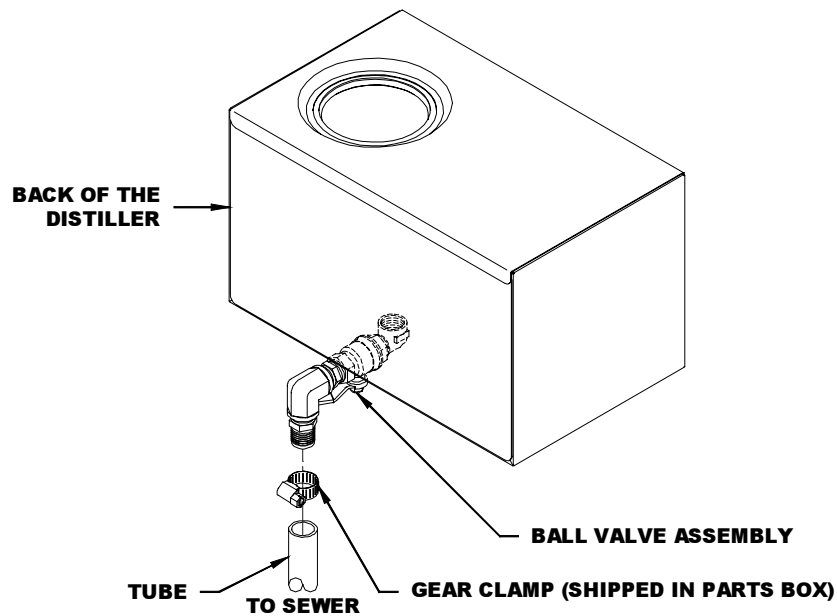

Drain Tube Removal Diagram

4. Remove the wall stabilizer clamp. Refer to the **Drain Tube Removal Diagram** above. Remove the gear clamp and drain hose from the barbed coupler on the rear of the water distiller head.
5. Remove the water distiller head from the charcoal filter canister and storage tank by lifting off from the storage tank.
6. Turn your water distiller head upside down.

7. Remove the drain elbow assembly and ball valve assembly using a 12" adjustable wrench. Save this to reinstall as part of the PWS AED-1.

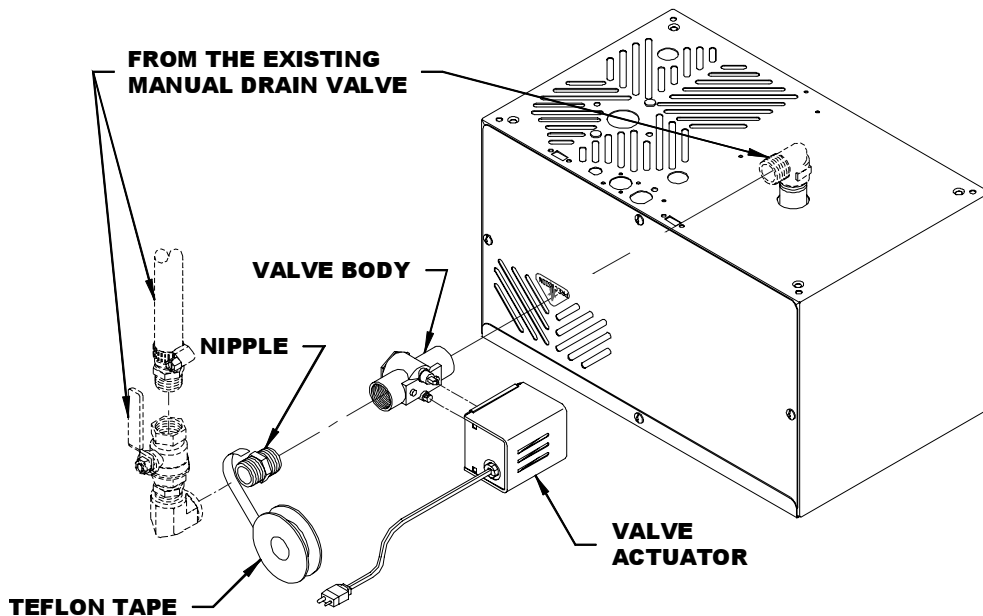

PWS AED-1 Plumbing Diagram

8. Refer to the **PWS AED-1 Plumbing Diagram** above. Use Teflon tape on all fittings to seal threads. Thread the Valve Body to the existing drain elbow. An arrow on the valve indicates the direction of flow. Flow is from the water distiller head down to the floor drain.
9. Tighten the valve using a 10" adjustable wrench or a 1-1/4" open end wrench so that the pins for the motor assembly box are facing the lid side of the water distiller head.
10. Install a 3/4" MPT Close Nipple into the valve using a 10" adjustable wrench.
11. Attach the drain elbow and ball valve assembly that was initially removed. Attach the barbed coupler onto the ball valve and tighten.
12. After checking that all fittings are tight, return the water distiller head to the upright position and reinstall on the charcoal filter canister and storage tank. Reconnect the control cable plug on the storage tank to the control cable receptacle on the bottom of the water distiller head by turning the plug until the splines lock and then turn the locking ring until finger tight.

- 13.** Attach the drain hose to the barbed coupler on the ball valve and secure with a gear clamp using a slotted screwdriver. Connect the wall stabilizer clamp. Run the drain hose to a suitable floor drain. The drain hose must have an air gap between the end of the hose and the floor drain. The air gap is necessary so that water can not be siphoned up the drain hose into the boiling chamber and also so that sewage gases do not rise up the drain hose and contaminate the water distiller.
- 14.** Connect the feed water line and turn the feed water line saddle valve on.

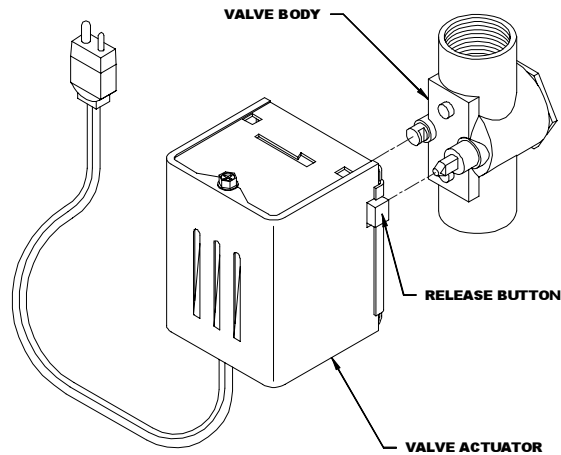

Auto Drain Valve Connection Diagram

- 15.** See the **Auto Drain Valve Connection Diagram** above. Attach the Motor Assembly Box to the drain valve by lining up the holes of the box with the pins on the valve, and snap it into place. The motor can be removed by pressing the release button and pulling the motor away from the valve assembly.
- 16.** Connect the two-pin plug from the valve motor box into the receptacle labelled 'Accessory Drain' on the bottom of the water distiller head. If the PWS APK-1 Pump Kit is installed on the water distiller connect the two-pin plug from the pump into the receptacle labelled 'Accessory Pump'.

NOTE: PWS APK-1 Pump and PWS AED-1 cord lengths are designed so they cannot be plugged into the incorrect receptacle.

- 17.** Plug the electrical cord into the wall outlet. Leave the ball valve in the open position during normal operation. The distiller is now ready to operate and drain the boiling tank automatically.

NOTE: With the automatic drain kit installed the ball valve is always left open while the water distiller is operating. When the water distiller is shut down for cleaning, the ball valve needs to be closed so the cleaning solution in the boiler tank will not drain out. This procedure is described in more detail in the maintenance section of the guide.

Additional Options

Sediment Pre-Filter Assembly #500359

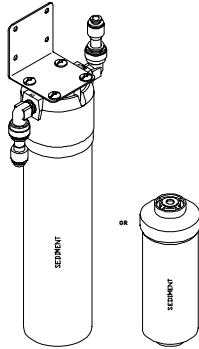

A Sediment Pre-Filter prevents particles from entering the water distiller that may plug components such as the water solenoid valve. It is most beneficial in applications where the water distiller's raw supply water has higher concentrations of sediment.

Charcoal Post-Filter Assembly #500360

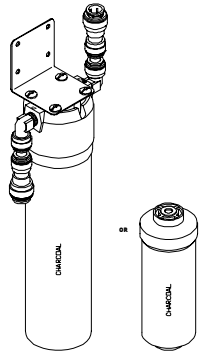

The Charcoal Post-Filter Assembly provides the same function as the Filter Canister located between the water distiller head and the storage tank, but has a greater capacity and does not need to be changed as often. This accessory works well in high volume applications.

Pressure Accumulator #080059

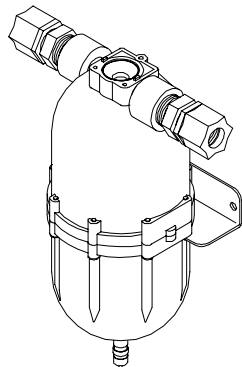

Used to help maintain pressure on the outlet side of the optional pump and prevent the pump from starting every time a small amount of water is required at the faucet, fridge or humidifier.

Water Distiller Cleaner and Descaler

600 g #500102

1600 g #500103

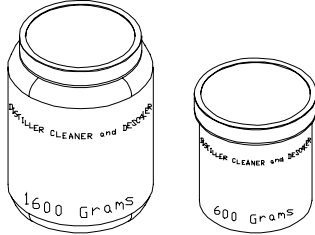

Used for regular maintenance to clean the scale out of the boiling tank. Dissolves water minerals in water distillers, coffeepots, dishwashers or most metal products where water scale is a problem.

Pure Activated Coconut Charcoal for Refillable Charcoal Filter Canisters

250 g #500106

600 g #500107



Contains 100% pure crushed coconut shells that have been steam activated at extremely high temperatures creating a porous grade of activated charcoal. This coconut charcoal can be used along with any type of home or commercial water distiller. Coconut charcoal is used to trap any gases or obnoxious odors that may escape the distillation process. Do not use any other charcoal such as aquarium type.

Tee Valve #034005

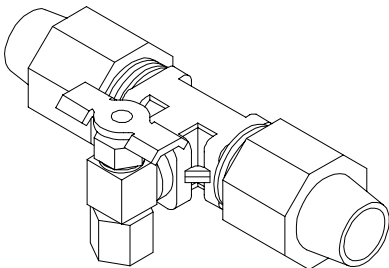

Used to divert distilled water from the pantry faucet supply line to other household uses.

All Options are available from your Precision Water Systems Dealer or Service Center

Specifications and Technical Information

Model	PWS 12-12
Electrical Specifications Voltage Amperage Power Frequency	120VAC 13.2 Amps 1500 Watts 60 Hertz
Water distiller Physical Size Height-w/ lid -w/o lid Width Depth-w/ SG & Drain -w/o SG & Drain	47" (119.4 cm) 46-1/2" (118.1cm) 18-1/2" (47.0 cm) 14" (35.6 cm) 13-5/8" (34.6cm)
Water distiller Weight Dry: Water distiller and Tank Only	57 lbs. (25.9 kg.)
Water distiller Production Capacity Approx. Prod. Capacity Approx. Daily Prod. Capacity	0.5 US gal/h (1.9 L/h)* 12 US gal/24 hrs.
Storage Tank Capacity Total Storage Capacity Useable Storage Capacity	13.5 US gal (51.1 L) 12 US gal (45.4 L)

*Note: Performance based on optimum conditions including water temperature, ambient temperature, line voltage, boiling tank cleanliness, boiler fill level, etc

Wiring List - PRECISION PURE 12-12/12-20 (12GPD AUTO) PART # 510126-S13

SERIES 13

No.	Part#	Color	Ga	Length	From Conn.	ToConn.	From Location	To Location
	1510121	GRN	16	3"	#10RING #14-#16	POWER CORD	GROUND	POWER CORD
	2510121	BLK	16	17.5"	F250 #14-#16	POWER CORD	POWER SWITCH #2	POWER CORD
	3510121	WHT	16	18.5"	#10RING #14-#16	POWER CORD	RESET SWITCH #4	POWER CORD
	4510122	BLKor	18	12"	PIGG#18-#22&F250#18-#22	FAN MOTOR (ORG/BLU)	HEATER RELAY #4	FAN MOTOR
	5510122	BLKor	18	12"	F250 #18-#22&PIGG#18-#22	FAN MOTOR (YLW/WHT)	FAN SWITCH #2	FAN MOTOR
6								
7								
8								
	9095001	BLK	16	7"	#10RING #14-#16	F187 #14-#16	RESET SWITCH #1	Lower Microswitch COM
	10095033	GRN	16	23"	PIGG #14-#16	F250 #14-#16	HEATER RELAY "B"	SOLENOID VALVE A
	11095034	BLK	16	26"	F187 #14-#16	F250 #14-#16	Upper Microswitch COM	SOLENOID VALVE B
	12510123	BLK	18	3.5"	F250 #18-#22	PUMP RECEPTACLE	FUSE SIDE	PUMP RECEPTACLE (SMOOTH)
	13510123	BLK	18	24"	#10RING #18-#22	PUMP RECEPTACLE	RESET SWITCH #3	PUMP RECEPTACLE (RIBBED)
	14095035	ORG	16	20"	#10RING #14-#16	FPIN	RESET SWITCH #3	HOLDING TANK RECEPTACLE #1
	15095036	BLU	16	19"	F250 #14-#16	FPIN	HEATER RELAY #6	HOLDING TANK RECEPTACLE #2
	16095004	YLW	16	7"	PIGG #14-#16	FPIN	SOLENOID VALVE A	HOLDING TANK RECEPTACLE #3
	17095037	RED	16	22"	F250 #14-#16	FPIN	PUMP RELAY "B"	HOLDING TANK RECEPTACLE #4
	18095006	RED	16	8"	F250 #14-#16	#10RING #14-#16	POWER SWITCH #3	RESET SWITCH #2
	19510124	BLK	18	20"	PIGG #18-#22	DRAIN RECEPTACLE	WATER SWITCH #7	DRAIN RECEPTACLE (RIBBED)
	20510124	BLK	18	20"	#10RING #18-#22	DRAIN RECEPTACLE	RESET SWITCH #1	DRAIN RECEPTACLE (SMOOTH)
	21095007	WHT	16	4"	#10RING #14-#16	#10RING #14-#16	RESET SWITCH #1	HEATING ELEMENT "A"
	22095008	YLW	16	13"	F250 #14-#16	#10RING #14-#16	HEATER RELAY #4	HEATING ELEMENT "B"
	23095009	BRN	16	7"	F250 #14-#16	PIGG#14-#16	PUMP RELAY "A"	POWER SWITCH #2
	24095010	WHT	16	3"	F250 #14-#16	PIGG#14-#16	PUMP RELAY #6	PUMP RELAY "A"
	25095038	GRN	16	22"	F250 #14-#16	F250 #14-#16	PUMP RELAY #9	FUSE END
	26095010	WHT	16	3"	PIGG #14-#16	F250 #14-#16	HEATER RELAY "B"	HEATER RELAY #9
	27095012	BRN	16	12"	F250 #14-#16	#10RING #14-#16	HEATER RELAY #7	RESET SWITCH #3
	28095013	ORG	16	9"	F250 #14-#16	#10RING #14-#16	FAN SWITCH #3	RESET SWITCH #1
	29095014	RED	16	11"	#10RING #14-#16	F250 #14-#16	HEATING ELEMENT "B"	POWER SWITCH #7
	30095010	WHT	16	3"	F250 #14-#16	PIGG #14-#16	FAN SWITCH #6	POWER SWITCH #7
	31095010	WHT	16	3"	F250 #14-#16	PIGG #14-#16	FAN SWITCH #7	FAN SWITCH #2
	32095015	BRN	16	12"	F250 #14-#16	#10RING #14-#16	FAN SWITCH #8	RESET SWITCH #4
	33095016	BLU	16	11"	F250 #14-#16	#10RING #14-#16	POWER SWITCH #8	RESET SWITCH #4
	34095010	WHT	16	3"	F250 #14-#16	PIGG#14-#16	POWER SWITCH #6	POWER SWITCH #3
	35095017	BLU	16	10"	F250 #14-#16	F250 #14-#16	HEATER RELAY #9	WATER SWITCH #7
	36095018	GRN	16	14"	F250 #14-#16	#10RING #14-#16	WATER SWITCH #8	RESET SWITCH #4
	37095039	BRN	16	24"	F250 #14-#16	PIGG #14-#16	WATER SWITCH #6	SOLENOID VALVE B
	38095020	YLW	16	5"	F250 #14-#16	PIGG #14-#16	WATER SWITCH #2	FAN SWITCH #3
	39095021	GRN	16	13"	F187 #14-#16	F250 #14-#16	Lower Microswitch NC	HEATER RELAY "A"
	40095022	ORG	16	14"	F187 #14-#16	F250 #14-#16	Upper Microswitch NC	WATER SWITCH #3

Index

- Boiling Tank Lid, 25
- Capacities
 - distilled production, 61
 - storage tank, 61
- Charcoal
 - changing, 35
- Charcoal Filter
 - installing Canister, 35
 - replacing charcoal, 35
- Cleaning
 - boiling tank using the cleaner descaler, 33
 - regular inspection and cleaning of the boiling tank, 32
- Control Cable, Connection, 24
- Descaler
 - instructions, 33
- Drain tube, 21
- Electrical
 - location, 14
 - requirements, 14
- Electrical Connections
 - water distiller head, 54
- Feed Water Line Connection, 22
- Fuse Replacement, 29
- Household Plan for Water Distiller Set Up, 53
- Hydrological Cycle, 13
- Inspection-boiling tank, 32
- Installation
 - drain tube, 21
 - feed water line, 22
 - PWS AED-1 automatic electric drain kit, 55
 - PWS APK-1 pump kit, 48
 - sight gauge and valve, 19
 - wall stabilizer, 26
 - water distiller tools, 17
- Lid
 - boiling tank, 25
 - storage tank, 25
- Location-suitable distiller, 14
- Maintenance and Cleaning, 32
 - record table, 41
 - schedule, 41
- Manual Fill Operation, 30
- Operation, 27
 - fan switch, 28
 - normal, 31
 - overheat reset switch, 29
 - power switch, 28
 - storage tank drain valve, 29
 - water switch, 28
- Options
 - charcoal post-filter assembly, 59
 - charcoal-replacement order, 60
 - cleaner and descaler-replacement order, 60
 - pressure accumulator, 59
 - pump kit installation, 48
 - PWS AED-1 automatic electric drain kit, 55
 - PWS APK-1 pump kit, 47
 - sediment pre-filter assembly, 59
 - tee valve, fridge, 60
- Pantry Faucet Assembly, 52
- Production
 - water, 10
- Record of purchase, 5
- Safety Precautions, 7
- Schematics
 - 12 GPD, 63
- Service Center Locator, 46
- Shipping Tie Removal, 17
- Startup-Summary, 8
- Sterilization, 36
 - liquid-storage tank, pump and water lines, 36
 - steam-water distiller head, 37
 - steam-water distiller head, filter canister and storage tank, 39
- Strainer Removal-boiling tank, 33
- Terminology, 9
- Troubleshooting, 42
- Unpacking, 15
- Warranty, 6
 - Precision Water Distiller, 6
 - registration, 65
- Weights, 61
- Wiring List
 - 12 GPD, 62

Precision Water Distiller Warranty Registration

IMPORTANT!

Precision Design & Mfg Inc.

IMPORTANT!

Thank you for purchasing this fine Precision Water Distiller.
Please complete the information below and return it within the next ten days so we may register your purchase.

Last Name

--	--	--	--	--	--	--	--	--	--	--	--	--	--	--	--	--	--	--	--

First Name

--	--	--	--	--	--	--	--	--	--	--	--	--	--	--	--	--	--	--	--

Address: (Mailing)

--	--	--	--	--	--	--	--	--	--	--	--	--	--	--	--	--	--	--	--

City

Province/State

Country

--	--	--	--	--	--	--	--	--	--	--	--	--	--	--	--	--	--	--	--

--	--	--	--	--	--	--	--	--	--	--	--	--	--	--	--	--	--	--	--

--	--	--	--	--	--	--	--	--	--	--	--	--	--	--	--	--	--	--	--

Zip Code/Postal Code

--	--	--	--	--	--	--	--	--	--	--	--	--	--	--	--	--	--	--	--

Date of Purchase:

Month

Day

Year

--	--	--	--	--	--	--	--	--	--	--	--	--	--	--	--	--	--	--	--

--	--	--	--	--	--	--	--	--	--	--	--	--	--	--	--	--	--	--	--

--	--	--	--	--	--	--	--	--	--	--	--	--	--	--	--	--	--	--	--

Phone Number:

--	--	--	--	--	--	--	--	--	--	--	--	--	--	--	--	--	--	--	--

--	--	--	--	--	--	--	--	--	--	--	--	--	--	--	--	--	--	--	--

--	--	--	--	--	--	--	--	--	--	--	--	--	--	--	--	--	--	--	--

PWS Model Number

PWS 12-12

Serial Number

--	--	--	--	--	--	--	--	--	--	--	--	--	--	--	--	--	--	--	--

Series:

--	--	--	--	--	--	--	--	--	--	--	--	--	--	--	--	--	--	--	--

Purchased From:

--	--	--	--	--	--	--	--	--	--	--	--	--	--	--	--	--	--	--	--

Please fill in information completely and mail directly to:

Precision Design & Manufacturing Inc.
10331 – 105th Street
Westlock, Alberta, Canada
T7P 2H7

Or Fax To: 780-349-4957

This page left intentionally blank